

• 15R0102B200 •

SINUS PENTA PENTA MARINE

MULTIFUNCTION AC DRIVE

USER MANUAL -Programming Guide-

Issued on 05/06/17
R.03
SW Ver. 4.13x

English

- This manual is integrant and essential to the product. Carefully read the instructions contained herein as they provide important hints for use and maintenance safety.
- The information contained herein is the property of Brammer and cannot be reproduced. Brammer enforces its rights on the drawings and catalogues according to the law.
- This device is to be used only for the purposes it has been designed to. Other uses should be considered improper and dangerous. The manufacturer is not responsible for possible damages caused by improper, erroneous and irrational uses.
- Brammer is responsible for the device in its original setting.
- Any changes to the structure or operating cycle of the device must be performed or authorized by the Engineering Department of Brammer.
- Brammer assumes no responsibility for the consequences resulting by the use of non-original spare-parts.
- Brammer reserves the right to make any technical changes to this manual and to the device without prior notice. If printing errors or similar are detected, the corrections will be included in the new releases of the manual.

The logo for iDrive, featuring the word "iDrive" in a blue, sans-serif font. The "i" is lowercase and the "D" is uppercase. The "i" has a small dot above it. The "D" is a large, bold letter. The "r" is lowercase and the "i" is lowercase. The "v" is lowercase and the "e" is lowercase. The "e" has a small tail that curves upwards.

Brammer AS.
Nordre Bruraas 18
5131 Nyborg
Norway

BRAMMER.NO info@BRAMMER.NO

REVISION INDEX

Modifications in respect to Programming Guide 15R0102B200, release R.02, SW version 4.12x issued on 25/08/16.

The following subjects covered in this Programming Guide R.03 (SW version 4.13x) have been added, changed or suppressed in respect to the previous version R.02 (SW version 4.12x).

Logo ENERTRONICA GROUP added.

Measures **M004u/M009u** added.

Parameters **P268s/t/u/v** added.

Selection **D74**: kWh pulse added in Table 48: List of the selectable digital signals and analog variables.

Description of customized PID measures **M023/023a/024/024a** corrected.

MODBUS addresses of measures **M120/121/122** corrected.

MODBUS address in version SW Texas corrected.

Modbus DATE AND TIME MENU addresses corrected.

Clamp transistor in braking unit renamed.

Wording "side A" removed from description of IGBT alarms.

VTC procedure to make torque demand and generated torque equivalent added.

USER MANUALS MENTIONED IN THIS PROGRAMMING GUIDE

The following User Manuals from Brammer are mentioned throughout this Programming Guide:

- **15P0102B100** SINUS PENTA - Installation Guide
- **15Q0102B00** SINUS PENTA - Guide to the Regenerative Application
- **15Q0102B200** SINUS PENTA - Guide to the Synchronous Motor Application
- **15W0102B300** SINUS PENTA Safe Torque Off Function - Application Manual
- **15W0102B500** Motor Drives Accessories - User Manual
- **15G0010B1** PROFIdrive COMMUNICATIONS BOARD - Installation and Programming Guide
- **15G0851B100** DATA LOGGER ES851 - Programming Guide
- **15J0901B100** RemoteDrive DRIVE REMOTE CONTROL - User Manual

0. TABLE OF CONTENTS

0.1. Chapters

REVISION INDEX	2
0. TABLE OF CONTENTS	3
0.1. Chapters	3
0.2. Figures	8
0.3. Tables	9
0.4. Scope of this Manual	12
0.5. How to Use this Manual	12
0.5.1. Overview	12
0.5.2. Special Applications Dedicated to Sinus Penta Drives	12
0.5.3. Menus and Submenus	13
0.5.4. Alarms and Warnings	15
1. USING THE DISPLAY/KEYPAD UNIT	16
1.1. Overview	16
1.2. Menu Tree	17
1.3. Navigation	19
1.4. Parameter Modification	21
1.5. Programming the Root Page	21
1.6. Using the MENU Key	22
1.7. ESC Key	23
1.8. RESET Key (Alarm and Control Board Reset)	24
1.9. TX/RX Key (Download/Upload from/to the Keypad)	24
1.10. LOC/REM Key (Keypad Pages)	26
1.11. SAVE/ENTER Key	26
1.12. Indicator LEDs on the Display/Keypad	27
2. DESCRIPTION OF INPUT AND OUTPUT SIGNALS	28
3. REFERENCES AND FEEDBACKS	29
3.1. Main Speed/Torque Reference	29
3.2. Speed/Torque Limit Reference	29
3.3. PID Reference	29
3.4. PID Feedback Reference	29
4. PROGRAMMABLE FUNCTIONS	30
4.1. Multimotor	30
4.2. Voltage/Frequency Pattern	30
4.3. Slip Compensation	30
4.4. Speed Searching	30
4.5. Controlled Stop in Case of Power Failure (Power Down)	30
4.6. DC Braking	30
4.7. Motor Thermal Protection	30
4.8. Prohibit Speeds	31
4.9. Digital PID Regulator	31
4.10. Bridge Crane Application	31
4.11. Setting Two Alternative Command Sources and Reference Sources	31
4.12. Fire Mode	32
5. PROGRAMMING EXAMPLES	33
5.1. Overview	33
5.2. Programming a Reference	33
5.3. Configuring the External Torque Limit	37
5.4. Configuring the Feedback from Incremental Encoder	38
5.5. Configuring a Reference from Incremental Encoder	39
6. START-UP MENU	40
6.1. Overview	40
7. FIRST STARTUP	42
7.1. "IFD" Control Algorithm	42
7.2. "VTC" Control Algorithm	45
7.3. "FOC" Control Algorithm	49
8. MEASURES MENU	54
8.1. Overview	54
8.2. Motor Measures Menu	55

8.3.	PID Regulator Menu.....	63
8.4.	Digital Inputs Menu	67
8.5.	References Menu.....	70
8.6.	Outputs Menu	74
8.7.	Temperature Measures from PT100 Menu	76
8.8.	Autodiagnostics Menu.....	77
8.9.	Data Logger Measures Menu.....	79
8.10.	Encoder Measures Menu	81
8.11.	Digital Input Settings Menu	82
8.12.	Fault List Menu	83
8.13.	Power Off List Menu.....	85
9.	PRODUCT MENU	87
9.1.	Overview	87
9.2.	List of Parameter P263 and Fire Mode Enable Password	87
10.	PASSWORD AND USER LEVEL MENU.....	91
10.1.	Overview	91
10.2.	List of Parameters P000 to P003	91
11.	DISPLAY/KEYPAD MENU.....	93
11.1.	Overview	93
11.2.	Root Page	93
11.3.	Keypad Page and Local Mode	94
11.4.	List of Parameters P264 to P269b	95
12.	RAMPS MENU.....	103
12.1.	Overview	103
12.1.1.	Description of the Speed Ramps.....	103
12.1.2.	Description of the Torque Ramps.....	106
12.2.	List of Parameters P009 to P033	107
13.	INPUTS FOR REFERENCES MENU	116
13.1.	Processing Speed/Torque References	116
13.2.	Scaling Analog Inputs REF, AIN1, AIN2	119
13.3.	List of Parameters P050 to P074a	123
14.	MULTISPEED MENU.....	136
14.1.	Overview	136
14.2.	List of Parameters P080 to P100	136
15.	PID MULTIREFERENCES MENU	139
15.1.	Overview	139
15.2.	List of Parameters P080a to P099a	141
16.	MULTITORQUE MENU	143
16.1.	Overview	143
16.2.	List of Parameters P101 to P103	143
17.	PROHIBIT SPEED MENU	144
17.1.	Overview	144
17.2.	List of Parameters P105 to P108	145
18.	REFERENCE VARIATION PERCENT MENU	146
18.1.	Overview	146
18.2.	List of Parameters P115 to P121	148
19.	SPEED LOOP AND CURRENT BALANCING MENU	149
19.1.	Overview	149
19.2.	List of Parameters P125 to P153	151
20.	FOC REGULATORS MENU	155
20.1.	Overview	155
20.2.	List of Parameters P155 to P173	155
21.	VTC REGULATORS MENU.....	158
21.1.	Overview	158
21.2.	List of Parameters P175h1 to P175w	158
22.	ANALOG AND FREQUENCY OUTPUTS MENU.....	162
22.1.	Overview	162
22.1.1.	Factory-setting of the Analog Outputs.....	162
22.1.2.	Analog Outputs.....	162
22.1.3.	Frequency Output.....	164
22.2.	Variables.....	165
22.2.1.	Operating Mode of Analog and Frequency Outputs	166
22.2.2.	Analog Output Programming Examples	167
22.3.	List of Parameters P176 to P215	171

23.	TIMERS MENU	183
23.1.	Overview	183
23.2.	List of Parameters P216 to P229	185
24.	PID PARAMETERS MENU	189
24.1.	Overview	189
24.2.	PID Regulator Tuning – Method of Ziegler and Nichols	190
24.3.	Manual Tuning of the PI Regulator	191
24.3.1.	Proportional Action (P)	191
24.3.2.	Integral Action (I)	193
24.3.3.	Derivative Action (D)	196
24.3.4.	Tuning Actions at Constant Speed	196
24.4.	Anti-windup	196
24.5.	List of Parameters P236 to P260	197
25.	PID2 PARAMETERS MENU	205
25.1.	Overview	205
25.2.	List of Parameters P436 to P460	206
26.	DIGITAL OUTPUTS MENU	207
26.1.	Overview	207
26.1.1.	Factory Settings	207
26.1.2.	Structure of the Digital Outputs	207
26.2.	Programmable Operating Modes (Diagrams)	219
26.3.	Examples	223
26.4.	List of Parameters P270 to P305	228
27.	AUXILIARY DIGITAL OUTPUTS MENU	242
27.1.	Overview	242
27.2.	List of Parameters P306 to P317	242
28.	MEASURE CONTROL FROM PT100	246
28.1.	Overview	246
28.2.	List of Parameters P318 to P325	246
29.	FIELD BUS PARAMETERS MENU	249
29.1.	Overview	249
29.2.	List of Parameters P330 to P331	249
30.	VIRTUAL DIGITAL OUTPUTS (MPL) MENU	251
30.1.	Overview	251
30.1.1.	Factory Setting	251
30.1.2.	Structure of the Virtual Digital Outputs	251
30.2.	Operating Diagram of the Virtual Digital Outputs	257
30.3.	List of Parameters P350 to P385	261
31.	INPUTS FOR REFERENCES FROM OPTIONAL BOARD	275
31.1.	Scaling Analog Inputs XAIN4, XAIN5	275
31.2.	List of parameters P390 to P399	276
32.	AUTOTUNE MENU	281
32.1.	Overview	281
32.1.1.	Motor Autotune and Adjusting Loops	281
32.1.2.	Checking the Encoder Operation	284
32.2.	List of Inputs I073 - I074	285
33.	CARRIER FREQUENCY MENU	286
33.1.	Overview	286
33.1.1.	Carrier Frequency Setting	286
33.1.2.	Example	286
33.1.3.	Maximum Programmable Speed Value	288
33.2.	List of Parameters C001 to C004	289
34.	MOTOR CONFIGURATION MENU	291
34.1.	Overview	291
34.1.1.	Electrical Specifications of the Connected Motor	292
34.1.2.	Motor Ratings	292
34.1.3.	Parameters of the Equivalent Circuit of the Asynchronous Machine	293
34.1.4.	V/f Pattern (IFD Only)	294
34.1.5.	Example 1 - V/f Pattern Parameterization	295
34.1.6.	Example 2 - V/f Pattern Parameterization	296
34.1.7.	Slip Compensation (IFD Only)	296
34.1.8.	Torque Control (VTC and FOC Only)	297
34.1.9.	Torque Follower Mode (VTC and FOC only)	298
34.1.10.	Field Weakening (VTC and FOC Only)	299

34.2.	List of Parameters C008 to C128.....	302
34.3.	Tables Including the Parameters Depending on the Drive Model.....	322
34.3.1.	Voltage Class 2T/4T.....	322
34.3.2.	Voltage Class 5T/6T.....	330
35.	LIMITS MENU.....	335
35.1.	Overview.....	335
35.2.	List of Parameters C043 to C135.....	337
36.	CONTROL METHOD MENU.....	341
36.1.	Overview.....	341
36.1.1.	Command Sources.....	342
36.1.2.	Speed/Torque REFERENCE Sources.....	345
36.1.3.	Alternative Command and Reference Sources.....	348
36.1.4.	Torque Limit Source.....	349
36.1.5.	Remote/Local Mode.....	349
36.2.	How to Manage the Reference Sources.....	350
36.3.	List of Parameters C140 to C148.....	353
37.	DIGITAL INPUTS MENU.....	356
37.1.	Overview.....	356
37.1.1.	START.....	359
37.1.2.	ENABLE (Terminals 15:MDI2 and S).....	360
37.1.3.	RESET (Terminal 16:MDI3).....	363
37.2.	Factory-setting of the Digital Inputs.....	364
37.3.	List of Parameters C149 to C188c and I006.....	364
38.	ENCODER/FREQUENCY INPUTS MENU.....	390
38.1.	Overview.....	390
38.1.1.	When ES836 is NOT Used.....	390
38.1.2.	When Using ES836 or ES913 Optional Board.....	391
38.1.3.	When Using Two Encoders.....	392
38.2.	List of Parameters C189 to C199.....	394
39.	BRAKING UNIT AND RAMP EXTENSION MENU.....	399
39.1.	Overview.....	399
39.1.1.	Braking unit and ramp extension.....	399
39.1.2.	Torque Limit and Frequency Increase Due to Overvoltage – SVC (Smart Voltage Control).....	400
39.2.	List of Parameters C210 to C213d.....	401
40.	DC BRAKING MENU.....	404
40.1.	Overview.....	404
40.1.1.	DC Braking at Start and Non-condensing Function.....	404
40.1.2.	DC Braking at Stop.....	406
40.1.3.	DC Braking Command Sent from Digital Input.....	407
40.2.	List of Parameters C215 to C224.....	410
41.	POWER DOWN MENU.....	413
41.1.	Overview.....	413
41.2.	List of Parameters C225 to C235.....	416
42.	SPEED SEARCHING MENU.....	420
42.1.	Overview.....	420
42.2.	List of Parameters C245 to C250.....	425
43.	AUTORESET MENU.....	429
43.1.	Overview.....	429
43.2.	List of Parameters C255 to C258.....	429
44.	MOTOR THERMAL PROTECTION MENU.....	431
44.1.	Overview.....	431
44.2.	Choosing the Characteristic Parameters.....	432
44.2.1.	IEC Class.....	432
44.2.2.	Maximum Locked Rotor Time – Basic.....	432
44.2.3.	Maximum Locked Rotor Time – Enhanced.....	435
44.3.	Thermal Protection Trip Delay.....	436
44.4.	List of Parameters C264 to C274.....	437
45.	MAINTENANCE MENU.....	440
45.1.	Overview.....	440
45.2.	List of Parameters C275 to C278.....	440
46.	PID CONFIGURATION MENU.....	441
46.1.	Overview.....	441
46.2.	Operation and Structure of the PID Regulator.....	441
46.3.	List of Parameters C285 to C294.....	444

46.4.	Keeping Fluid Level Constant (Example).....	451
46.5.	Example of Compensation of Voltage Drop in a Filter	454
46.5.1.	Voltage Drop Compensation – Feedback from Single Analog Input	454
46.5.2.	Voltage Drop Compensation - Feedback from Two Analog Inputs	455
47.	BRIDGE CRANE MENU	456
47.1.	Overview	456
47.2.	List of Parameters C300 to C303.....	456
48.	DATE AND TIME MENU	459
48.1.	Overview	459
48.2.	List of Parameters C310 to C316.....	462
49.	TIMED FLAGS MENU.....	465
49.1.	Overview	465
49.2.	Examples	465
49.3.	List of Parameters from C330 to C357	466
50.	SERIAL COMMUNICATIONS	470
50.1.	Overview	470
50.2.	MODBUS–RTU PROTOCOL	470
51.	SERIAL LINKS MENU	474
51.1.	Overview	474
51.1.1.	Watchdog Alarms	474
51.2.	List of Parameters R001 to R013.....	476
52.	FIELDBUS CONFIGURATION MENU	479
52.1.	Overview	479
52.1.1.	Alarm A070 (Communication Suspended)	479
52.2.	List of Parameters R016 to R018b and I080.....	480
52.3.	Exchanged Parameters	483
52.3.1.	From the Master to the Sinus Penta.....	483
52.3.2.	From the Sinus Penta to the Master.....	487
53.	EXPANSION BOARD CONFIGURATION MENU	490
53.1.	Overview	490
53.2.	List of Parameters R021 to R023.....	490
54.	PROFIDRIVE BOARD CONFIGURATION MENU	491
54.1.	Overview	491
54.2.	List of Parameters R025 to R045.....	491
55.	DAYLIGHT SAVING TIME	494
55.1.	Overview	494
55.2.	List of Parameters R050 to R053.....	494
56.	DATA LOGGER MENU.....	496
56.1.	Overview	496
56.2.	List of Parameters R115 and R116.....	496
57.	EEPROM MENU	498
57.1.	Overview	498
57.2.	List of Inputs I009 to I013.....	499
58.	ALARMS AND WARNINGS	501
58.1.	What Happens When a Protection Trips	501
58.2.	What To Do When an Alarm Trips.....	502
58.3.	Alarm List.....	503
58.4.	List of the DRIVECOM Alarm Codes	523
58.5.	Warnings.....	525
58.6.	Warning List.....	526
58.7.	State List.....	527
59.	CUSTOM PARAMETERS	528
60.	INDEX.....	541

0.2. Figures

Figure 1: Menu Tree.....	18
Figure 2: Navigation example	19
Figure 3: Display/keypad	27
Figure 4: Example of S ramps.....	104
Figure 5: Speed profile without Rounding Off and with Rounding Off 2 (example).....	105
Figure 6: Speed profile with Acceleration Reset - Yes to No (Example).....	106
Figure 7: Speed Reference computing	117
Figure 8: Torque Reference computing	118
Figure 9: Computing Speed Analog Reference from terminal board: AIN1	120
Figure 10: Computing Inputs REF (1) and (2) (examples).....	121
Figure 11: Computing REF Input (Example 3).....	122
Figure 12: Prohibit Speed ranges	144
Figure 13: Speed Control (example).....	147
Figure 14: Example of dual parameterization activated by a digital input.....	149
Figure 15: Error threshold Dual Parameterization function (example).....	150
Figure 16: Typical structure of the Analog Outputs.....	163
Figure 17: Structure of the Frequency Output.....	164
Figure 18: Curve (voltage; speed) implemented by AO1 (Example 1).....	167
Figure 19: Curve (voltage; speed) implemented by AO1 (Example 2).....	168
Figure 20: Curve (voltage; speed) implemented by AO1 (Example 3).....	168
Figure 21: Curve (voltage; speed) implemented by AO1 (Example 4).....	169
Figure 22: Curve (voltage; speed) implemented by AO1 (Example 5).....	170
Figure 23: Using Timers (example).....	184
Figure 24: PID Block Diagram	189
Figure 25: Permanent oscillation with K_p critical gain	190
Figure 26: Response to a system tuned with the method of Ziegler and Nichols	191
Figure 27: Response to the step based on the value of K_p when T_i is kept constant.....	192
Figure 28: Response to the step when K_p is too large	193
Figure 29: Response to the step based on the value of T_i when K_p is kept constant.....	194
Figure 30: Response to the step when the values of K_p and T_i are too small	195
Figure 31: PID Sleep and Wake-up Mode when P237a is set to 1	199
Figure 32: MDO block-diagram	207
Figure 33: DIGITAL Mode	219
Figure 34: ANALOG Mode	220
Figure 35: DOUBLE DIGITAL Mode	221
Figure 36: General structure of the parameterization of a digital output	222
Figure 37: Digital output for speed thresholds (example)	224
Figure 38: Electromechanical brake command (example).....	225
Figure 39: Block diagram of the virtual digital outputs (MPL).....	251
Figure 40: Example of MPL functionality.....	257
Figure 41: Carrier frequency (example)	286
Figure 42: Equivalent circuit of the asynchronous machine.....	293
Figure 43: Types of programmable V/f curves	294
Figure 44: Comparing the static field weakening to the automatic field weakening	300
Figure 45: Torque control with speed limit	308
Figure 46: Torque limit for VTC and FOC controls in field weakening mode	335
Figure 47: Current limit reduction based on carrier frequency: models with I_{peak}	336
Figure 48: Current limit reduction based on carrier frequency: models without I_{peak}	336
Figure 49: Selecting the command sources.....	342
Figure 50: Selecting the source references	348
Figure 51: Inputs that can be selected to implement control functions	356
Figure 52: The ENABLE Function.....	361
Figure 53: Controlling Run and Direction when the STOP Input is not programmed.....	369
Figure 54: Controlling Run and Direction when the STOP Input is programmed.....	370
Figure 55: Using two encoders (example)	392
Figure 56: SVC (Smart Voltage Control).....	400
Figure 57: DCB Hold and DCB at Start.....	404
Figure 58: DCB at Start with VTC Control.....	405
Figure 59: DCB at Stop	406
Figure 60: Manual DCB (Example 1)	407
Figure 61: Manual DCB (Example 2).....	408

Figure 62: Manual DCB (Example 3)	409
Figure 63: Power Down (Example)	414
Figure 64: Speed Searching (Example 1)	421
Figure 65: Speed Searching (Example 2)	423
Figure 66: Trip current reduction depending on speed values	431
Figure 67: Set up of parameter C267 depending on the LRC/FLC ratio	435
Figure 68: Trip delay of alarm A075 based on the IEC Class	436
Figure 69: Structure of the PID Regulator	441
Figure 70: Reference source and feedback source selection	442
Figure 71: PID ramp reference	443
Figure 72: Details of the PID regulator structure	443
Figure 73: Keeping fluid level constant (Example)	451

0.3. Tables

Table 1: Coding of Measures M031, M032	67
Table 2: Coding of Measure M033	67
Table 3: Coding of Measures M034, M035	69
Table 4: Coding of Measures M036, M036a, M036b	69
Table 5: Coding of Measure M056	74
Table 6: Coding of Measure M056a	74
Table 7: Coding of Measure M056b	74
Table 8: Coding of Measure M061	75
Table 9: Data Logger connection status	80
Table 10: Coding of the functions assigned to the digital inputs	82
Table 11: Modbus base addresses in the Fault Lists	84
Table 12: List of the measures in the Fault Lists	84
Table 13: List of the measures in the Power Off List	86
Table 14: List of Parameter P263 and Fire Mode Enable Password	87
Table 15: Indexes corresponding to the different models of the Penta Drive	88
Table 16: Voltage classes of the Penta Drive	88
Table 17: Fan control modes	89
Table 18: Coding for fan activation	89
Table 19: List of Parameters P000 to P003	91
Table 20: List of Parameters P264 to P269b	95
Table 21: Preset units of measure	98
Table 22: List of the programmable measures for P268, P268a, P268b, P268c, P268d, P268e	100
Table 23: Example of a Speed Ramp	103
Table 24: List of Parameters P009 to P033	107
Table 25: Parameters used for the Inputs for References Menu	116
Table 26: Analog Input Hardware Mode	119
Table 27: List of Parameters P050 to P074a	123
Table 28: List of Parameters P080 to P100	136
Table 29: List of Parameters P080a to P099a	141
Table 30: List of Parameters P101 to P103	143
Table 31: List of Parameters P105 to P108	145
Table 32: List of Parameters P115 to P121	148
Table 33: List of Parameters P125 to P153	151
Table 34: List of Parameters P155 to P173	155
Table 35: List of Parameters P175a1 to P175w	158
Table 36: Selectable variables for the Analog and Frequency Outputs	165
Table 37: Programming AO1 (0 ÷ 10V)	167
Table 38: Programming AO1 (0 ÷ 10V)	167
Table 39: Programming AO1 (ABS 0 ÷ 10V)	168
Table 40: Programming AO1 (ABS 0 ÷ 10V)	169
Table 41: Programming AO1 (± 10V)	169
Table 42: List of Parameters P176 to P215	171
Table 43: List of Parameters P216 to P229	185
Table 44: Coding of Parameters P226 to P229	187
Table 45: List of Parameters P236 to P260	197
Table 46: List of Parameters P436 to P460	206
Table 47: Digital Output Mode	208

Table 48: List of the selectable digital signals and analog variables	210
Table 49: Test functions	215
Table 50: MDO parameterization for PD Status OK	223
Table 51: MDO parameterization for drive Run OK	223
Table 52: MDO parameterization for speed thresholds	224
Table 53: MDO parameterization for electromechanical brake command	225
Table 54: MDO parameterization for the PWM function	226
Table 55: MDO parameterization for the Ready state of a PLC supervisor	227
Table 56: List of Parameters P270 to P305	228
Table 57: List of Parameters P306 to P317	242
Table 58: List of Parameters P318 to P325	246
Table 59: List of Parameters P330 to P331	249
Table 60: List of the programmable measures for P330 to P331	250
Table 61: Virtual Digital Output Modes	252
Table 62: Test functions	253
Table 63: MPL parameterization for Dry Run Detection	258
Table 64: MPL parameterization for Pipe Fill function	260
Table 65: List of Parameters P350 to P385	261
Table 66: Analog input hardware mode	275
Table 67: List of Parameters P390 to P399	276
Table 68: Programmable "Motor Tune" functions	282
Table 69: List of Inputs I073 - I074	285
Table 70: Maximum value of the output frequency depending on the Penta model	288
Table 71: List of Parameters C001 to C004	289
Table 72: Description of the parameters classified by motor	292
Table 73: Motor ratings	292
Table 74: Parameters of the equivalent circuit of the asynchronous machine	293
Table 75: Motor parameters used by control algorithms	293
Table 76: IFD control parameters for the connected motors	295
Table 77: Parameters setting Slip Compensation (IFD Control)	296
Table 78: List of Parameters C008 to C128	302
Table 79: Equivalence between AC mains range and DC range	305
Table 80: Coding of Parameters C011c (C054c, C097c) and C012 (C055, C098)	309
Table 81: Parameters depending on the Drive Model - Class 2T/4T / 1	322
Table 82: Parameters depending on the Drive Model - Class 2T/4T / 2	324
Table 83: Parameters depending on the Drive Model - Class 2T/4T / 3	326
Table 84: Parameters depending on the Drive Model and Voltage Class - Class 2T/4T / 4	328
Table 85: Parameters depending on the Drive Model - Class 5T/6T / 1	330
Table 86: Parameters depending on the Drive Model - Class 5T/6T / 2	331
Table 87: Parameters depending on the Drive Model - Class 5T/6T / 3	333
Table 88: Parameters depending on the Drive Model an Voltage Class - Class 5T/6T / 4	334
Table 89: List of Parameters C043 to C135	337
Table 90: Enable conditions of the command sources	343
Table 91: Remote command inputs from serial link	344
Table 92: Enable conditions of the reference sources	345
Table 93: Reference inputs from serial link	347
Table 94: List of Parameters C140 to C148	353
Table 95: Unprogrammable functions	358
Table 96: Terminals used for other inputs	358
Table 97: Terminal board: Factory-setting	364
Table 98: List of Parameters C149 to C188c and I006	364
Table 99: Coding of Parameters C154 and C154a	372
Table 100: Multispeed selection	373
Table 101: Selected Speed reference	373
Table 102: Multiramp selection	377
Table 103: Selected ramp	377
Table 104: Motor selection	381
Table 105: Selection of the speed reference variation	382
Table 106: Variation of the selected speed reference	382
Table 107: Multitorque selection	388
Table 108: Selected Multitorque reference	388
Table 109: Selection of PID Multireferences	389
Table 110: List of Parameters C189 to C199	394
Table 111: Coding of Parameter C189	395

Table 112: Coding of Parameter C199	398
Table 113: List of Parameters C210 to C213d	401
Table 114: List of Parameters C215 to C224	410
Table 115: List of Parameters C225 to C235	416
Table 116: List of Parameters C245 to C250	425
Table 117: List of Parameters C255 to C258	429
Table 118: Suggested values for the motor thermal time constant	432
Table 119: Typical datasheet for 4-pole, 50Hz-400V motors	433
Table 120: List of Parameters C264 to C274	437
Table 121: List of Parameters C275 to C278	440
Table 122: Reference sources from serial link	444
Table 123: List of Parameters C285 to C294	444
Table 124: List of Parameters C300 to C303	456
Table 125: List of Parameters C310 to C316	462
Table 126: List of Parameters C330 to C357	466
Table 127: List of Parameters R001 to R013	476
Table 128: List of Parameters R016 to R018b and I080	480
Table 129: Coding of Parameters R018, R018a and R018b	481
Table 130: List of Parameters R021 to R023	490
Table 131: List of Parameters R025 to R045	491
Table 132: List of Parameters R050 to R053	494
Table 133: List of Parameters R115 and R116	496
Table 134: Preset connections	497
Table 135: List of Inputs I009 to I013	499
Table 136: List of the possible alarms	503
Table 137: List of the DRIVECOM alarm codes	523
Table 138: Warning list	526
Table 139: State list	527

0.4. Scope of this Manual

Brammer is committed to update its User Manuals available for download from BRAMMER.NO with the latest software version officially released. Please contact Brammer if you require technical documents related to previous software versions.

0.5. How to Use this Manual

0.5.1. OVERVIEW

This User Manual (Programming Guide) provides any information required to setup and monitor the drives of the Sinus Penta series manufactured by Brammer SpA.

Setup/monitoring may be obtained using one of the following options:

- Display/keypad unit;
- Serial link through RS485 standard port or ES822 (isolated optional serial board) RS485/RS232;
- ES851 (optional Data Logger and communications board).

For the instructions on how to use and remote the display/keypad unit, please refer to the Installation Guide and the Motor Drives Accessories - User Manual.



Any information sent to/from the drive via the display/keypad unit may be obtained also via serial link using the RemoteDrive software application offered by Brammer. This application allows the following functions: image acquisition, keypad simulation, oscilloscope functions and multifunction tester, data logger, table compiler including history data, parameter setup and data reception-transmission-storage from and to a computer, scan function for the automatic detection of the connected drives (up to 247 drives may be connected).

You can also create your own dedicated software via serial communication link. This manual provides any information concerning addressing (Address field) and scaling (Range field) for the drive interfacing.

0.5.2. SPECIAL APPLICATIONS DEDICATED TO SINUS PENTA DRIVES

Special software is supplied with the drives of the Sinus Penta series, that can be used for particular applications. The menu tree, the programming mode and navigation mode of the Sinus Penta are used; parameters or menus will be added/(removed) whether required/(not required) for the implemented application.

The dedicated applications implement the most common automation applications, thus replacing PLCs or dedicated control boards, and they reduce to a minimum the electric equipment required, thus ensuring lower maintenance costs. Such operating modes can be implemented through the firmware updating and/or through additional interface boards. The following applications are currently available:

Identifier	Application
PD	Sinus Penta Drive (Asynchronous Motor control)
PR	Regenerative Sinus Penta (see Guide to the Regenerative Application)
PS	Sinus Penta – Synchronous Motor Control (see Guide to the Synchronous Motor Application)



NOTE

In order to install your application SW and update the firmware packages of the SINUS PENTA drive, you can use the RemoteDrive software provided by Brammer. Please refer to the RemoteDrive DRIVE REMOTE CONTROL - User Manual for detailed instructions.

0.5.3. MENUS AND SUBMENUS

This User Manual (Programming Guide) is divided into different Menus. Their sequence is the same as their display sequence in the display/keypad and the RemoteDrive software.

Programming parameters and Measure parameters are divided into:

Mxxx Measures (always Read Only):

Mxxx	Range	Drive representation (integer)	Display on the display/keypad and the RemoteDrive (may be a decimal figure) plus unit of measure
	Active	Type of control (IFD / VTC / FOC) the measure is related to	
	Address	Modbus address which the measure can be read from (integer)	
	Function	Measure description	

Pxxx Parameters (always R/W):

Pxxx	Range	Drive representation (integer)	Display on the display/keypad and the RemoteDrive (may be a decimal figure) plus unit of measure
	Default	Factory-setting of the parameter (as represented for the drive)	Factory-setting of the parameter (as displayed) plus unit of measure
	Level	User level (BASIC / ADVANCED / ENGINEERING)	
	Address	Modbus address which the parameter can be read from (integer)	
	Control	This optional field is displayed when a parameter is not active for all types of motor controls (IFD / VTC / FOC)	
	Function	Parameter description	

Cxxx Parameters (Read Only when the drive is running and the motor is operating; R/W when the drive is in stand-by or in Run, but the motor is stopped: see **P003** in PASSWORD AND USER LEVEL MENU).

Cxxx	Range	Drive representation (integer)	Display on the display/keypad and the RemoteDrive (may be a decimal figure) plus unit of measure
	Default	Factory-setting of the parameter (as represented for the drive)	Factory-setting of the parameter (as displayed) plus unit of measure
	Level	User level (BASIC / ADVANCED / ENGINEERING)	
	Address	Modbus address which the parameter can be read from/written to (integer)	
	Control	This optional field is displayed when a parameter is not active for all types of motor controls (IFD / VTC / FOC)	
	Function	Parameter description	

Rxxx Parameters (Read Only when the drive is in Run; R/W when the drive is in stand-by or in Run, but the motor is stopped: see **P003** Condition required for changing C parameters in the PASSWORD AND USER LEVEL MENU).

Rxxx	Range	Drive representation (integer)	Display on the display/keypad and the RemoteDrive (may be a decimal figure) plus unit of measure
	Default	Factory-setting of the parameter (as represented for the drive)	Factory-setting of the parameter (as displayed) plus unit of measure
	Level	User level (BASIC / ADVANCED / ENGINEERING)	
	Address	Modbus address which the parameter can be read from/written to (integer)	
	Control	This optional field is displayed when a parameter is not active for all types of motor controls (IFD / VTC / FOC)	
	Function	Parameter description	



NOTE

Unlike **Cxxx** parameters, **Rxxx** parameters become active only after the drive has been switched off and switched on again, or after resetting its control board by pressing the **RESET** button for more than 5 seconds.

Ixxx Inputs. These are not parameters, but inputs (the values allocated to these inputs are not stored to non-volatile memory. Ixxx value is always 0 when the drive is powered on).

Ixxx	Range	Drive representation (integer)	Display on the display/keypad and the RemoteDrive (may be a decimal figure) plus unit of measure
	Level	User level (BASIC / ADVANCED / ENGINEERING)	
	Address	Modbus address which the input can be read from/written to (integer)	
	Control	This optional field is displayed when a parameter is not active for all types of motor controls (IFD / VTC / FOC)	
	Function	Input description	



NOTE Use the **ESC** key to enter the value of an **Ixxx** input. If the **SAVE/ENTER** key is used, **W17 SAVE IMPOSSIBLE** (warning) is displayed.



NOTE When changing a **Pxxx** or **Cxxx** parameter via the display/keypad, you may activate its new value immediately (flashing cursor) or when you quit the programming mode (fixed cursor). Typically, numeric parameters immediately come to effect, while alphanumeric parameters have a delayed effect.



NOTE When changing a **Pxxx** or **Cxxx** parameter via the RemoteDrive, the drive will immediately use the new parameter value.

0.5.4. ALARMS AND WARNINGS

The last part of this User Manual covers alarms (**Axxx**) and warnings (**Wxxx**) displayed by the drive:

Axxx	Description	
	Event	
	Possible cause	
	Solution	

1. USING THE DISPLAY/KEYPAD UNIT

1.1. Overview

This section contains several examples about navigating in the display/keypad unit and the UPLOAD and DOWNLOAD functions of the programming settings of the drive when using the keypad.

More details about the keypad settings (contrast, backlight, etc.) are given in the section covering the display/keypad in the Installation Guide. Details about custom navigation in the root page, the measures in the Keypad page and the Root page and the custom unit of measure of the PID controller are given in the DISPLAY/KEYPAD MENU in this manual.

When using the navigation “by menu” mode (**P264** = BY MENU), the structure of the menu tree that can be explored using the display/keypad is described in the Menu Tree section.

The complete tree structure is displayed, but the actual structure depends on the user level set in **P001** and on the implemented programming. For example, if only motor 1 is programmed (**C009**=1), the menus relating to motors 2 and 3 will not be displayed (Motor 2/3 Configuration and Motor 2/3 Limit). Also, if the type of motor control is **C010**=IFD Voltage/Freq., the BRIDGE CRANE MENU will not be displayed.

When **P264** = Linear (linear navigation), the parameters displayed are no longer grouped into menus, and you can scroll through all parameters using the ▲ and ▼ keys.

When **P264** = Modified Pars. Only, only the parameters having different values than the factory settings are displayed, and you can scroll through all parameters using the ▲ and ▼ keys.

The Navigation section shows how to use function keys to navigate through the parameters and to change parameter values (**P264** = BY MENU).

The function keys and their functionality are described below.

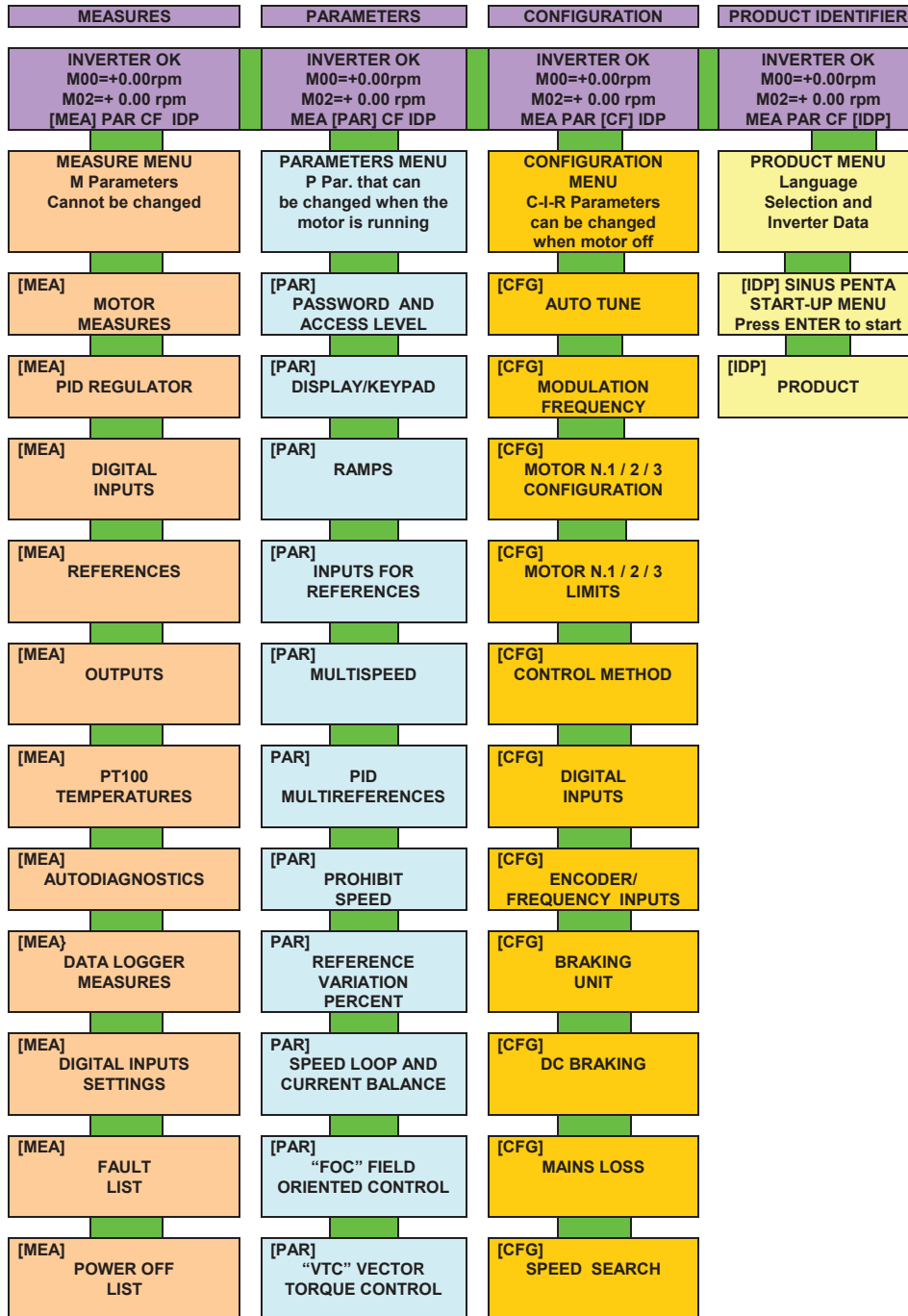

1.2. Menu Tree

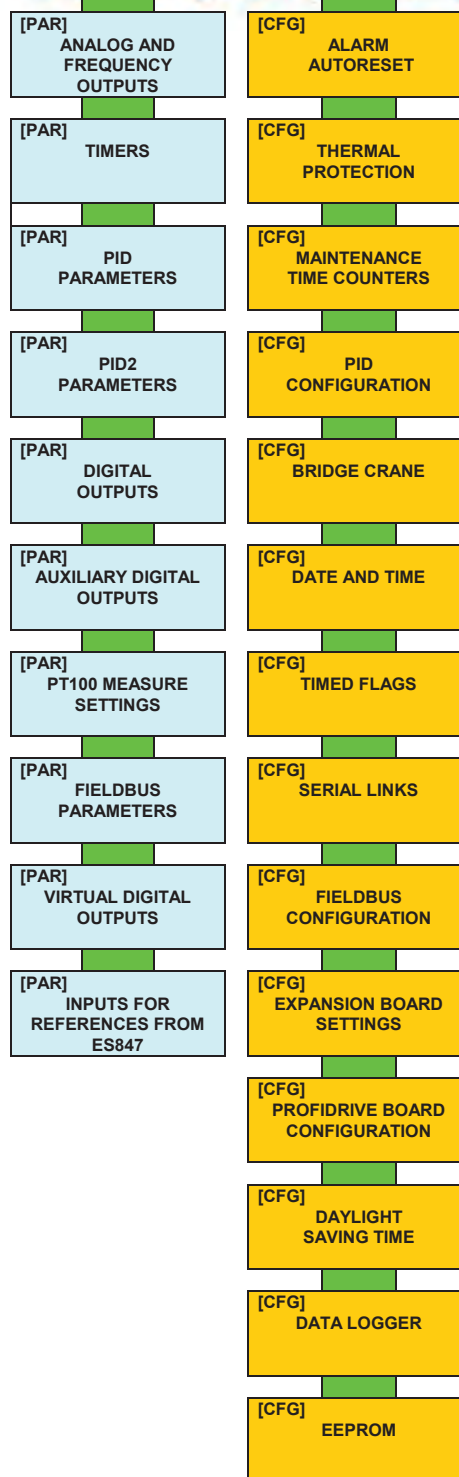
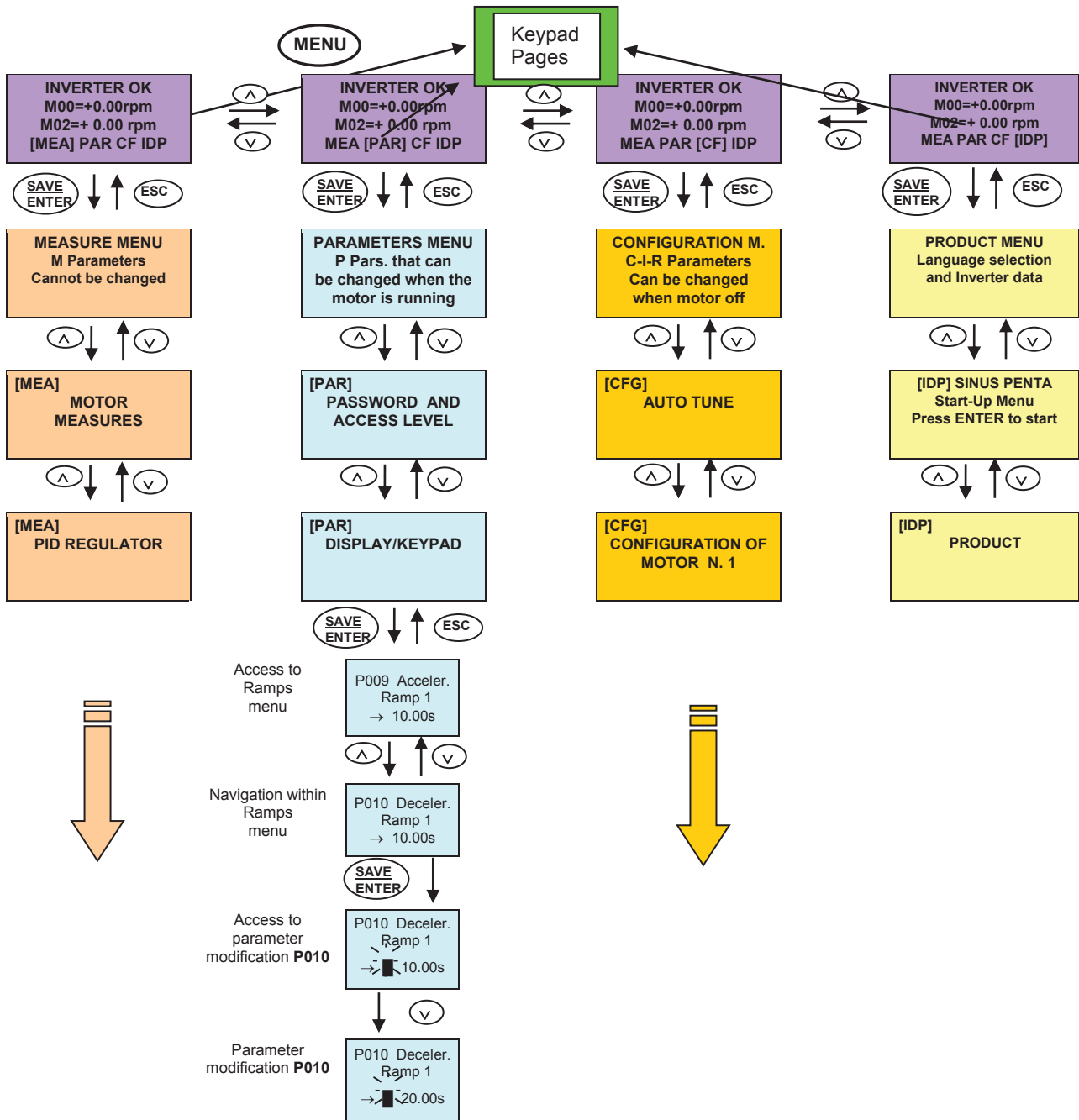

Figure 1: Menu Tree

1.3 Navigation

Figure 2: Navigation example



If the **ESC** key is pressed to quit, the new parameter value will be acknowledged but not saved to non-volatile memory, and will therefore be lost at power off. Press **SAVE/ENTER** to confirm parameter alteration.

**SINUS PENTA
PENTA MARINE**

iDrive

PROGRAMMING GUIDE

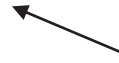

1.4. Parameter Modification

Factory setting allows parameter modification. The parameters included in the Parameters Menu (**Pxxx** parameters) can be changed at any moment, whereas the parameters included in the Configuration Menu (**Cxxx**, **Rxxx**, **Ixxx** parameters) can be changed only when the motor is stopped.

For safer operating conditions, the configuration parameters must be changed only when the drive is disabled (the **ENABLE-A** and **ENABLE-B** commands are inactive): to do so, **P003** must be set to **0 (stand-by only)**.

To disable parameter changes, just change **P000** (write enable) and save its new setting. **P000** and **P002** (password) are both factory-set to 1. If **P000=0**, an inexperienced user cannot change parameter values, but if **P000=1**, an advanced user will be able to change the parameter values.

For even safer operating conditions, you can change the password stored in **P002**; in that case, you must set **P000** accordingly.



NOTE Note down and keep at hand the value set in **P002**.

Press the **SAVE/ENTER** key for parameter modifications; when a flashing cursor appears, press **▲** and **▼** to change the parameter value. Do one of the following to quit the editing mode:

Press **ESC** with **P269b = 0**: [No] → the parameter value used by the drive is changed and is maintained until the drive is shut down, then the value is lost when the drive is powered on again.

Press **ESC** with **P269b = 1**: [YES] → the previous value is restored.

Press SAVE/ENTER → the parameter value is used by the inverter and stored to non-volatile memory and is not deleted when the drive is shut down.

Inputs (**Ixxx**) cannot be saved to non-volatile memory and are automatically set to their default values.

Rxxx parameters become active only when the drive control board has been reset by pressing the **RESET** key for a few seconds or by switching off the drive.

1.5. Programming the Root Page

When the drive is turned on, the Root page is displayed as the starting page. The Root page allows you to access the main menus (Measures, Parameters, Configuration, Product ID) or to shift to the Keypad pages using the **MENU** key.

Root page

I	N	V	E	R	T	E	R	O	K		
	+	1	5	0	0	.	0	0	r p m		
	+			0	.	0	0	r p m			
M	E	A	[P	A	R]	C	F	I	D	P

You can customise the root page using parameter **P265** (see the DISPLAY/KEYPAD MENU).

1.6. Using the MENU Key

The **MENU** key allows going to the next menu. From the Root page, press the MENU key to enable circular navigation.

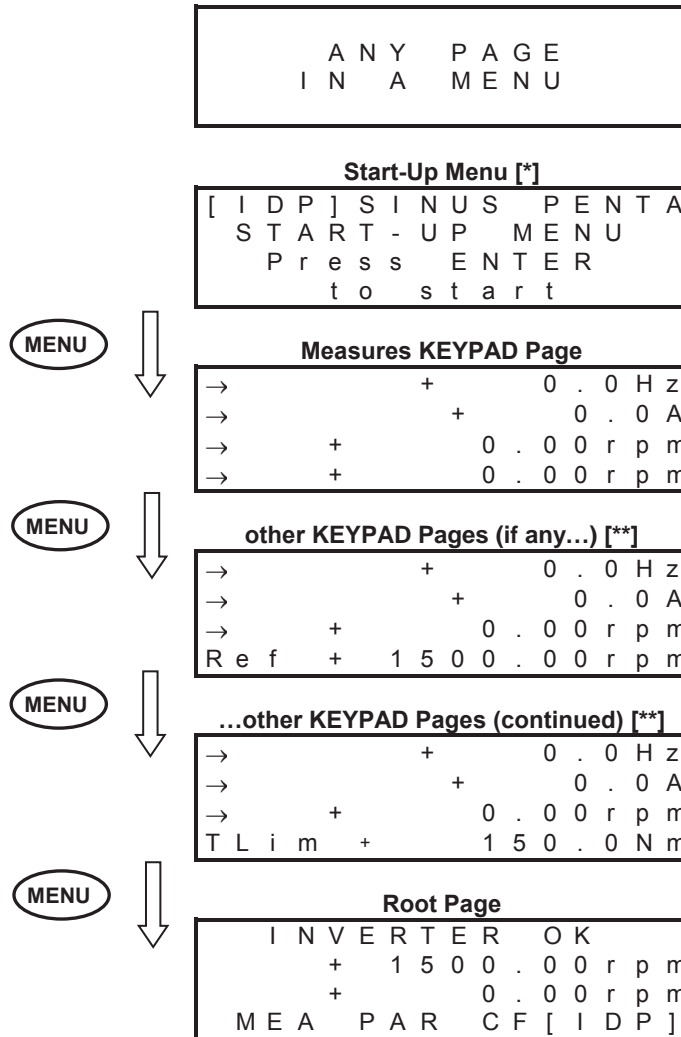

NOTE [*] The Start-Up menu is available only if **P265=3: Start-Up** (see the DISPLAY/KEYPAD MENU).



NOTE []** The other Keypad pages are available only if the relevant References / Feedback / Limits are activated (see the CONTROL METHOD MENU and the PID CONFIGURATION MENU).

1.7. ESC Key

Press the **ESC** key and to do the following:

1. move up one level in the menu tree;
2. go to the next field when changing a parameter having multiple value fields;
3. quit the editing mode without storing the value to EEPROM, or go back to the previous value based on **P269b**.

1. In the example below, starting from parameter **C015** in the MOTOR CONFIGURATION MENU inside the Configuration Menu, you can move up to the Root page by pressing the **ESC** key.

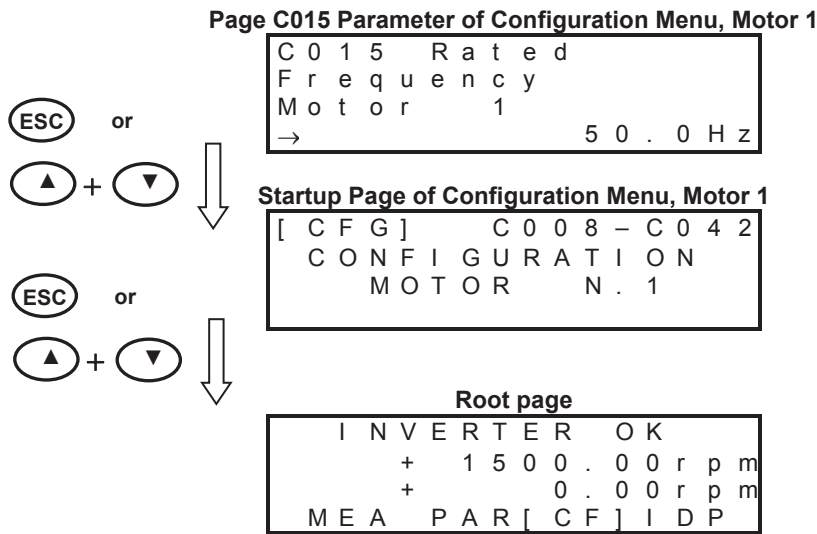

2. When using the **SAVE/ENTER** key to change a parameter including multiple fields (ESC> is displayed for the **ESC** key) press **ESC** to move to the next field. In the example below, 2 programmable fields are displayed for **P269**:

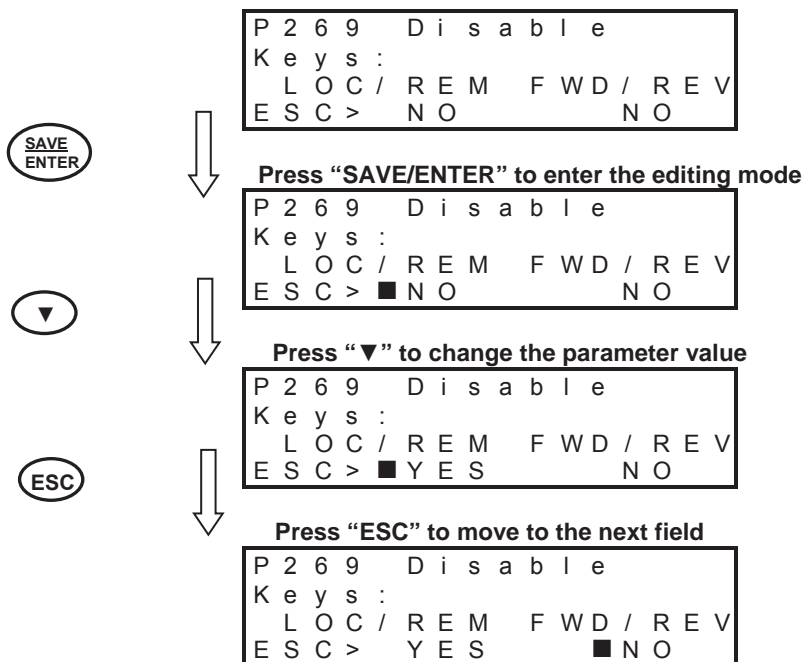

3. Press the following keys to quit the last page displayed:

- **ESC** without saving the value to EEPROM if **P269b = 0:[No]** → press **ESC** to confirm the parameter, that will not be saved (the previous value will be restored at next power on);
- **ESC** without saving the value to EEPROM if **P269b = 1:[No]** → press **ESC** to restore the previous value;
- **SAVE/ENTER** (new values are saved to EEPROM).

1.8. RESET Key (Alarm and Control Board Reset)

The **RESET** key is used to reset the drive after an alarm trips and the cause responsible for the alarm has been removed.

Press the **RESET** key for **more than 5 seconds to reset the control board and reinitiate it**. This procedure may be useful when changes made to **Rxxx** parameters (which activate only after resetting the equipment) must immediately come to effect, with no need to switch off the drive.

1.9. TX/RX Key (Download/Upload from/to the Keypad)

Use the keypad to perform the following functions:

1. **UPLOAD** (parameters stored in the drive are copied to the display/keypad);
2. **DOWNLOAD** (parameters stored in the keypad are copied to the drive).

Press the **TX/RX** key to go to the **UPLOAD** page; press the **TX/RX** key again to toggle between the **UPLOAD** and **DOWNLOAD** pages.



CAUTION

A Warning is displayed (one among **W41** to **W46**) when trying to **DOWNLOAD** parameters to a drive whose **SW Version, IDP, PIN** or current/voltage classes are different from those of the drive previously used for parameter **UPLOAD**. In that case, download is not allowed.



NOTE

The **DOWNLOAD** function allows the parameters stored in the keypad to be copied to the drive. However, parameters are not stored to the non-volatile memory of the drive. To store the downloaded parameters to the non-volatile memory of the drive, go to the **EEPROM** menu and execute a "Save Work" command once the download procedure is complete. Otherwise, when power is lost, the parameters downloaded to the drive are lost. See **EEPROM MENU**.

The **TX/RX** key is disabled under the following conditions:

- no password is entered in **P000**
- the **OPERATOR** mode is activated with the **MENU** Key (**P264b = OPERATOR**)
- the drive is running.

In the example below, you can go to the **UPLOAD** page from any page (the upper LED starts flashing). If you then press the **TX/RX** key, you can go to the **UPLOAD** and **DOWNLOAD** pages.

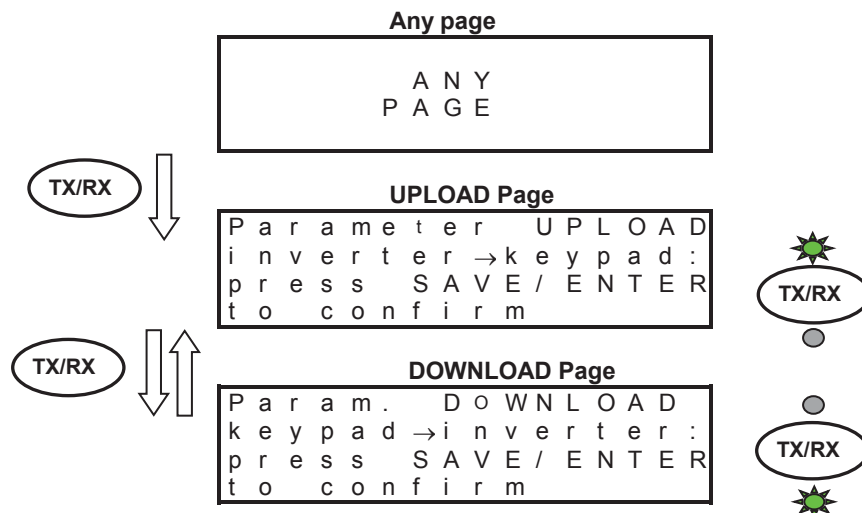



Press **SAVE/ENTER** from the UPLOAD (/DOWNLOAD) page to confirm UPLOADING (/DOWNLOADING). The relevant LED will come on (fixed light).

If the **SAVE/ENTER** key is not pressed for confirmation within 10 seconds from the selection of the **UPLOAD (/DOWNLOAD)** page, the starting page is automatically displayed.

While **UPLOADING**, **W08 UPLOADING** (flashing warning) appears.
 If parameters are successfully uploaded, the following warning appears:
W11 UPLOAD OK
 If not, the **W12 UPLOAD KO** warning appears. [Retry parameter upload.](#)

While **DOWNLOADING**, **W07 DOWNLOADING** (flashing warning) appears.
 If parameters are successfully downloaded, the following warning appears:
W09 DOWNLOAD OK
 If not, alarm **A073** trips, and download must be retried before restarting the drive.

1.10. LOC/REM Key (Keypad Pages)

To enable the Local/Remote operating mode (Remote sources are command and/or reference sources other than the display/keypad) press the **LOC/REM** key in the display/keypad, or use a digital input configured as **Loc/Rem** (see **C180**).



NOTE

The **LOC/REM** key is enabled when no digital input is configured as **Loc/Rem**, or when a digital input is configured as a **Loc/Rem** button (see **C180a**).
 The **LOC/REM** key is disabled when a digital input is configured as a **Loc/Rem** selector switch (see **C180a**).

C148 sets whether toggling between Remote mode and Local mode is activated only when the drive is disabled, or whether toggling from Remote to Local mode does not affect the drive running conditions (bumpless commands), but it does affect the reference. You can also choose to keep running conditions and reference unaffected (any command is bumpless). For more details, please refer to the description of parameter **C148** (CONTROL METHOD MENU).

In **LOCAL** mode (the **L-CMD** and **L-REF** LEDs come on), when drive references and commands are sent via display/keypad, the Keypad page allows changing the given reference using the **▲** and **▼** keys (see **P266** in the **DISPLAY/KEYPAD** menu).

When not in **LOCAL** mode, press the **MENU** key to access the Keypad pages from the root page. Only the Keypad pages relating to the Keypad source will be displayed along with the Measure Keypad page.

Example: Parameter **C147** (Torque/Speed Limit Reference Selection) is set to Keypad. From the root page, press the **MENU** key once to display the Measure Keypad page, and press the **MENU** key twice to display the Keypad page relating to the torque/speed limit and allowing changing the torque or speed limit reference using the **▲** and **▼** keys.

The Keypad page allows entering custom measures (see parameters **P268b** to **P268e** in the **DISPLAY/KEYPAD** menu).

From the Keypad pages, press the **SAVE/ENTER** key to access the Keypad Help page containing any details about the measures displayed in the Keypad page.

1.11. SAVE/ENTER Key

The **SAVE/ENTER** key allows selecting a lower level when navigating within the programming menus. It also allows changing a parameter value (to change a parameter value, press the **SAVE/ENTER** key from the page of the parameter you want to change). An example is given in Figure 2.

From the Keypad pages, the **SAVE/ENTER** key allows accessing the Keypad Help page containing the description of the displayed measures.

1.12. Indicator LEDs on the Display/Keypad

Eleven LEDs are located on the keypad, along with a 4-line, 16-character LCD display, a buzzer and 12 function keys. The display shows the parameter values, the diagnostic messages and the variables processed by the drive. The figure below shows the location of the indicator LEDs and their functionality.

Figure 3: Display/keypad

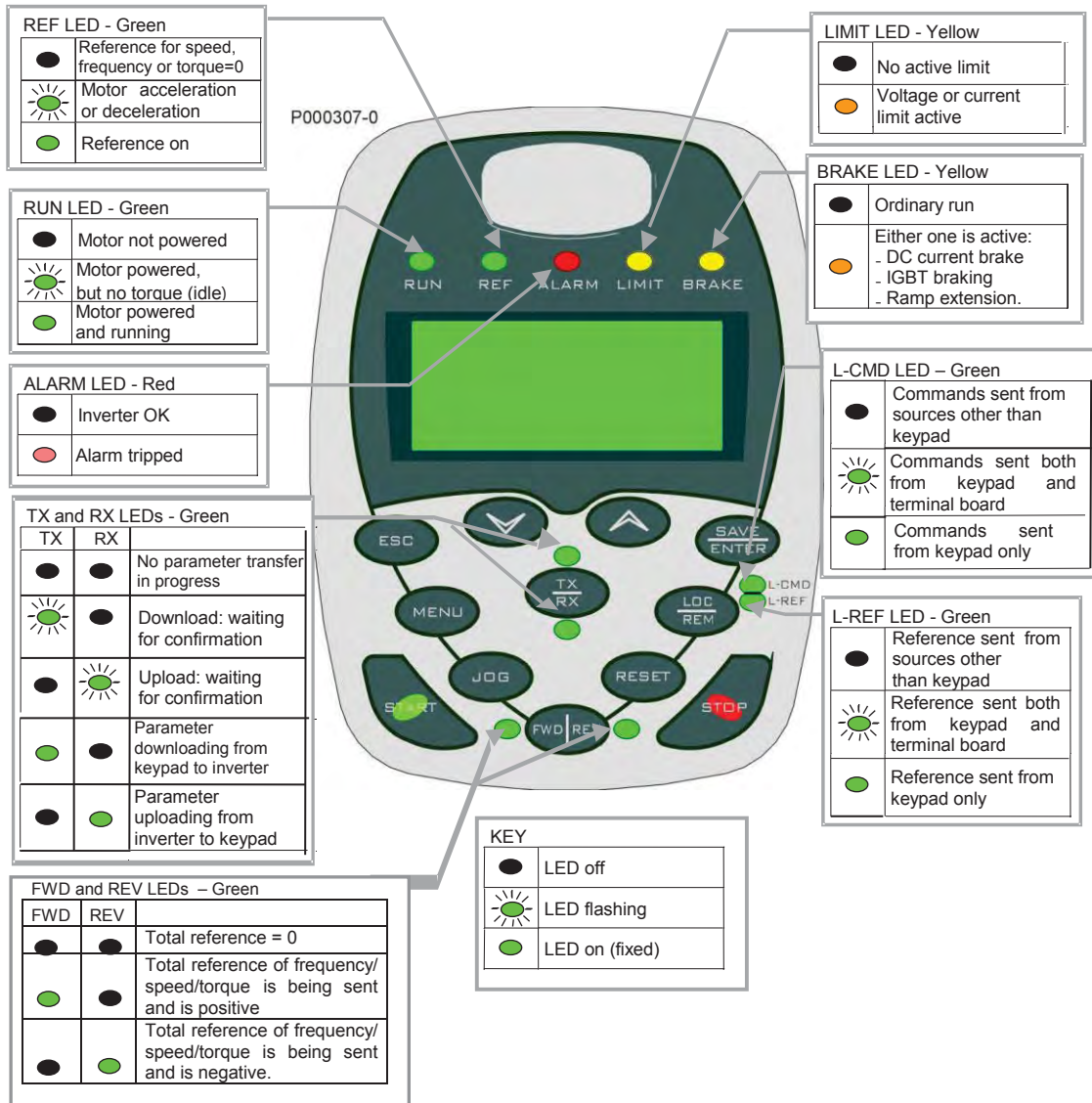

NOTE

See also the OPERATING AND REMOTING THE KEYPAD section in the Motor Drives Accessories - User Manual.

2. DESCRIPTION OF INPUT AND OUTPUT SIGNALS

The control board of the drives of the Sinus Penta series is provided with the following inputs/outputs:

- **3 Analog Inputs** (single-ended REF input, differential AIN1 & AIN2 inputs) that can be programmed as voltage/current inputs via SW1 DIP-switch (see Configuration DIP-switches in the Sinus Penta's Installation Guide).
- **3 Analog Inputs** that can be programmed as voltage/current inputs via SW2 DIP-switch (see Configuration DIP-switches in the Sinus Penta's Installation Guide).
- **8 MDI Multifunction Digital Inputs**; 3 of them (MDI6, MDI7, MDI8) are fast-acquisition inputs allowing acquiring frequency signal or encoder signals.
- MDI6 can be used to acquire a frequency signal called FINA; if used in conjunction with MDI7, it also allows acquiring a push-pull encoder signal called Encoder A.
- MDI8 can be used to acquire a frequency input called FINB (this avoids acquiring encoder B via **ES836** or **ES913** optional board).
- **4 MDO Multifunction Digital Outputs**; MDO1 is a Push-pull output, MDO2 is an Open Collector output and MDO3-4 are relay outputs.



NOTE Relay digital output **MDO4** is allocated to the **Safe Torque Off (STO)** function and cannot be configured by the user.

Electrical ratings of the control board inputs/outputs are given in the Sinus Penta's Installation Guide.

When programming:

- **Analog Inputs**, see the INPUTS FOR REFERENCES MENU
- **Analog Outputs**, see the ANALOG AND FREQUENCY OUTPUTS MENU
- **Digital Inputs**, see the DIGITAL INPUTS MENU
- **Digital Inputs used as Frequency/Encoder Inputs**, see the ENCODER/FREQUENCY INPUTS MENU
- **Multifunction Digital Outputs**, see the DIGITAL OUTPUTS MENU



CAUTION The drive is factory-set with the REF input configured as 0-10V and AIN1-AIN2 inputs configured as 4-20mA.
SW1 dip-switches, which are located on the control board, must be set as follows:

SW1

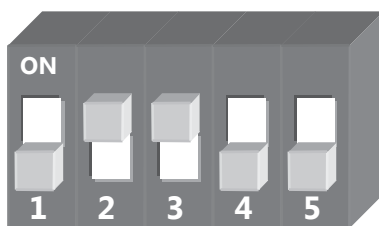

3. REFERENCES AND FEEDBACKS

The drive references are the following:

- Main speed/torque reference
- Speed/torque limit reference
- PID reference
- PID feedback

3.1. Main Speed/Torque Reference

If a speed control (e.g. **C011 = Speed** for Motor 1) is used, the main reference is a speed reference, while if a torque control is used (e.g. **C011=Torque** or **C011=Speed** for Motor 1, but the digital input is closed for the Slave programmed with **C170**), the main reference of the drive is a torque reference.

The main reference can be one of the following:

- Analog/digital inputs programmed as sources (see parameters **C143-C146** in the CONTROL METHOD MENU)
- PID output if **C294 PID Action = Reference**
- Digital inputs programmed as Multispeed (see MULTISPEED MENU) only when the main reference is a speed reference.

3.2. Speed/Torque Limit Reference

If a speed control is used (e.g. **C011 = Speed** for Motor 1) and a VTC or FOC algorithm is used, you can program a source as an external torque limit (see parameter **C147** in the CONTROL METHOD MENU).

If a torque control is used and an external speed limit has been set up (e.g. **C011 = Torque with Speed Limit** for Motor 1) and a FOC algorithm is used, you can program one source as an external speed limit (see parameter **C147** in the CONTROL METHOD MENU).

3.3. PID Reference

If the internal PID regulator is enabled (**C291 different from Disabled**), its reference is given by default by the sum of the three sources programmed as references (see parameters **C285-C287** in the PID CONFIGURATION MENU).

Different types of PID reference control (Two PIDs and 2-zone mode) are available based on the setting in parameter **C291a** (PID Control Mode).

3.4. PID Feedback Reference

The PID feedback by default is the sum of the three sources programmed as feedback (see parameters **C288-C290** in the PID CONFIGURATION MENU).

Different types of PID feedback control (Two PIDs and 2-zone mode) are available based on the setting in parameter **C291a** (PID Control Mode).

4. PROGRAMMABLE FUNCTIONS

4.1. Multimotor

The Sinus Penta drive provides 3 separate sets of parameters allowing configuring three control algorithms for 3 types of motors:

- **C009** Number of configured motors =2
- **C173** Digital input for Motor 2 = MDI6

When MDI6 is open, the parameters relating to Motor 1 are used for the motor control; when MDI6 is closed, the parameters relating to Motor 2 are used for the motor control (see the MOTOR CONFIGURATION MENU and the MULTISPEED MENU).

4.2. Voltage/Frequency Pattern

When using the Volt/Freq IFD control algorithm (e.g. **C010 = V/F IFD** for Motor 1), you can select different types of V/f patterns (see the V/f Pattern (IFD Only) section in the MOTOR CONFIGURATION MENU).

4.3. Slip Compensation

When using the Volt/Freq IFD control algorithm (e.g. **C010 = V/F IFD** for Motor 1), you can set the slip compensation function for a more accurate speed control (see the Slip Compensation (IFD Only) section in the MOTOR CONFIGURATION MENU).

4.4. Speed Searching

When using the Volt/Freq IFD or VTC VectorTorque control algorithm (e.g. **C010 = V/F IFD** for Motor 1), you can set the speed searching function for the motor speed of rotation, which is useful when the drive controls a motor which is already running (as for motors connected to fans). See the SPEED SEARCHING MENU for more details.

4.5. Controlled Stop in Case of Power Failure (Power Down)

See the POWER DOWN MENU to set a controlled stop in case of power failure.

4.6. DC Braking

When using the Volt/Freq IFD or Vector Torque VTC control algorithm, you can set DC braking at start or at stop. The DCB Hold function can be set for the Volt/Freq IFD function. See the DC BRAKING MENU for more details.

4.7. Motor Thermal Protection

The Motor Thermal Protection function protects the motor against possible overloads. This function can be obtained via a PTC acquired in AIN2 analog input—up to 6 PTCs can be series-connected—or it can be a software protection implemented through an algorithm reproducing the motor thermal image.

See the MOTOR THERMAL PROTECTION MENU for more details.

For more details about using AIN2 input, please refer to the Sinus Penta's Installation Guide.

4.8. Prohibit Speeds

Prohibit speeds are speed ranges corresponding to mechanical resonance frequencies. They prevent the drive from running at the preset speed ranges.

See the MULTITORQUE MENU for more details.

4.9. Digital PID Regulator

The Sinus Penta drive is provided with a digital PID (proportional, integral, derivative) regulator that can be used to implement the following:

- Analog output
- Main reference of the drive (Speed/Torque reference)
- Correction of the main reference
- Correction of the output voltage (only for Volt/Freq IFD control)

See the PID PARAMETERS MENU and the PID CONFIGURATION MENU for more details.

4.10. Bridge Crane Application

For hoisting applications, such as a bridge crane, it may be useful to consider the actual time required to release the safety electromechanical brake (the delay between the electrical command and the actual opening of the brake) and the closure of the electromechanical brake.

For a detailed description of the benefits offered by the parameters relating to hoisting applications, see the BRIDGE CRANE MENU.

4.11. Setting Two Alternative Command Sources and Reference Sources

You can set a digital input as a selector switch allowing selecting two alternative command sources and reference sources.

Example:

A selector switch is required to select **control mode B** (the drive references and commands are sent via fieldbus) and **control mode A** (the drive reference is sent via AIN1 analog input and commands are sent via keypad).

The following parameters shall be set up accordingly:

C179 MDI for source selection= **MDI6**

C140 Selection of command source n. 1 = **Keypad**

C141 Selection of command source n. 2 = **Fieldbus**

C143 Selection of reference n. 1 = **AIN1**

C144 Selection of reference n. 2 = **Fieldbus**

When MDI6 digital input in the terminal board is open (terminal 19), the command sources and reference sources n. 1 are selected (Keypad and AIN1 analog input, control mode A). When MDI6 is closed, the command sources and reference sources n. 2 are selected (Fieldbus, control mode B).



CAUTION

In the example above, if **C179 = Disable**, the OR logic for the Keypad and Fieldbus is considered, whereas the Fieldbus and AIN1 command sources are considered as summed up.

As an alternative to parameter **C179**, parameters **C179a** and **C179b** allow setting two digital inputs as independent selectors for the commands and the reference.

See also parameters **C179**, **C179a**, **C179b** in the DIGITAL INPUTS MENU.

4.12. Fire Mode

When the digital input programmed as FIRE MODE is activated, all the protecting functions of the drive are ignored, so that no alarm trips when the drive is operating.



CAUTION

The Fire Mode function must be used only when it is strictly necessary, such as in fire pumps, to protect human lives. This function must never be used to prevent alarms from tripping in domestic or industrial applications.



NOTE

To activate the parameters relating to the Fire Mode, enter the Password in the PRODUCT MENU. This Password is provided by Brammer's Service Department. The drive Serial Number is required (see the Serial Number parameter in the PRODUCT MENU).

The following parameters can be accessed only after entering the Password enabling the Fire Mode:

- **P032** Acceleration Ramp in Fire Mode (see the RAMPS MENU)
- **P033** Deceleration Ramp in Fire Mode (see the RAMPS MENU)
- **P099** Speed Fire Mode (see the MULTISPEED MENU)
- **C186** MDI Enabling Fire Mode (see the DIGITAL INPUTS MENU)

The Fire Mode is enabled when closing the MDI set through **C186**. The drive will use the speed reference set in **P099** and the ramp times set in **P032**, **P033**. All alarms will be ignored, except for the following:

A041	IGBT FAULT Side A	IGBT Hardware, general alarm
A044	OVERLOAD SW	Software Overcurrent
A048	OVER VOLTAGE	DC-bus voltage exceeding Vdc_max
A050	IGBT FAULT A	Hardware Fault from IGBT Driver
A051	OVERLOAD HW A	Hardware Overcurrent
A053	PWMA Not ON	Hardware Failure, IGBT cannot be fired
		<i>Control Board Failure</i>

When the Fire Mode is active, innumerable alarm autoresets are automatically enabled.



CAUTION

If an asterisk (*) appears next to INVERTER OK on the display, the product warranty is no longer valid. The asterisk appears if at least one condition requiring the activation of a protection feature occurs when the inverter is running in Fire Mode.

5. PROGRAMMING EXAMPLES

5.1. Overview

This section illustrates some programming examples for particular functions of the Penta drive. Flowcharts are used for easier reference.

For any detail concerning individual parameters, see the relevant sections in this manual.

5.2. Programming a Reference

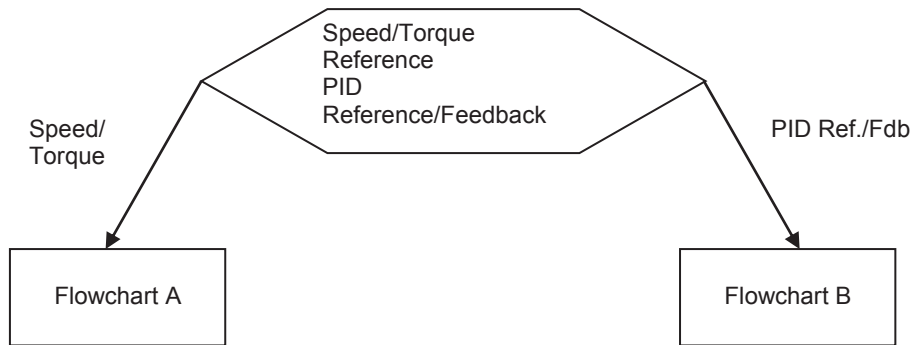

FLOWCHART A

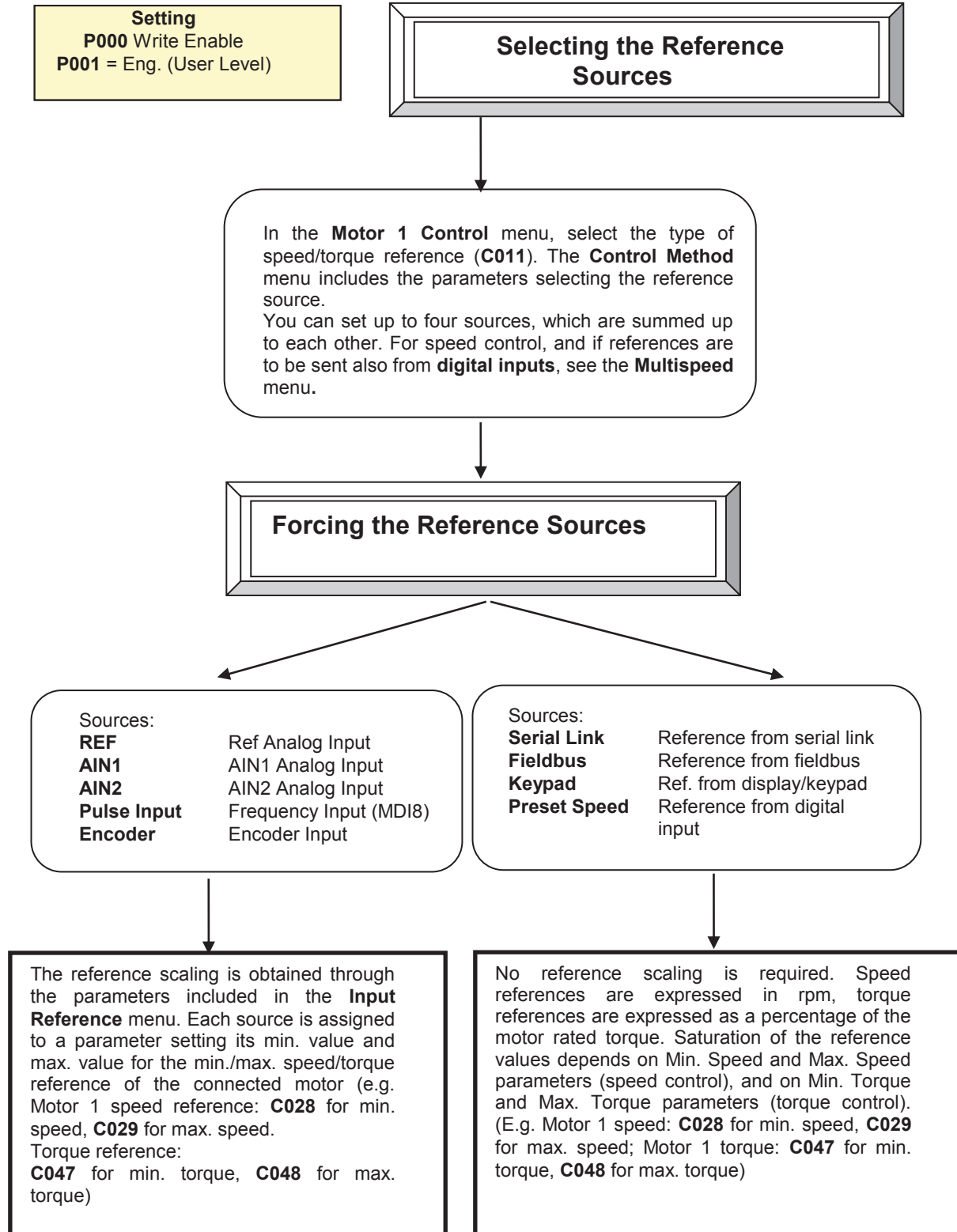

FLOWCHART B

Setting
P000 Write Enable
P001 = Eng. (User Level)

**Selecting the
Ref/Feedback Sources**

The **PID Configuration** menu includes the parameters selecting the reference/feedback source. You can set up to three sources, which are summed up to each other.

**Forcing the
Reference/Feedback
Sources**

Sources:

REF	Ref Analog Input
AIN1	AIN1 Analog Input
AIN2	AIN2 Analog Input
Pulse Input	Frequency Input (MDI8)
Encoder	Encoder Input

Sources:

Serial Link	Reference from serial link
Fieldbus	Reference from fieldbus
Keypad	Ref. from display/keypad
Feedback reference only :	
Iout	Output current
Vout	Output voltage
Vdc	DC bus voltage
Pout	Output power

The reference scaling is obtained through the parameters included in the **Reference** menu. Each source is assigned to a parameter setting its min. value and max. value for the min./max. PID Reference/Feedback value. See the **PID Parameters** menu.

Reference	P245 Min., P246 Max.
Feedback	P247 Min., P248 Max.

No reference scaling is required. References are expressed as a percentage. As a feedback reference, output current (Iout), output voltage (Vout), DC bus voltage (Vdc) are available, which refer (as full-scale values) to the following:
 Rated current of the selected motor (Mot.1 **C018**)
 Rated voltage of the selected motor (Mot.1 **C019**)
 DCb Bus 1500 V.

EXAMPLE:

The speed of a motor is to be controlled via a 0 ÷ 5 V analog input. Speed range is 0 ÷ 1500 rpm; two digital inputs are available to increase three speed values with steps of 100rpm.

Setting the min. and max. speed:

The parameters for the motor min./max. speed are **C028** = 0 rpm, **C029** = 1800 rpm.

Setting the analog reference:

Default setting: the analog reference is sent from REF input (**C143** = REF).

The speed range for the analog input must be 0 ÷ 1500 rpm.

Default setting in the INPUTS FOR REFERENCES MENU for REF analog input:

P050 = 3: 0 –10 V Type of reference for REF input

P051 = 0.0 V Min. value for REF input

P052 = 10.0 V Max. value for REF input

P052 is the voltage value for REF input for a speed reference of 1800rpm (**C029**)

For a speed reference of 1500rpm with 5 V, **P052** is to be set as follows:

(Max. speed REF): (5 V) = (**C029**): (Vx)

$Vx = 5\text{ V} * 1800\text{rpm} / 1500\text{rpm} = 6\text{ V}$

If **P052** = 6V, a speed reference of 1500rpm is set for REF with 5V.

Setting the reference from digital inputs:

Default setting: two digital inputs for multispeed values.

Digital Inputs Menu: **C155** = MDI4; **C156** = MDI5

Depending on the status of digital inputs MDI4 and MDI5:

MDI4	MDI5	Multispeed
0	0	0
1	0	1
0	1	2
1	1	3

In the MULTISPEED MENU, set the speed steps as follows:

P080 = 1: Sum Speed

P081 = 100rpm Multispeed 1

P083 = 200rpm Multispeed 2

P085 = 300rpm Multispeed 3

P080 → Multispeed function: the selected multispeed is summed up to the reference for the analog input.

P081, P083, P085 are the steps depending on the selected multispeed for digital inputs MDI4, MDI5.

5.3. Configuring the External Torque Limit

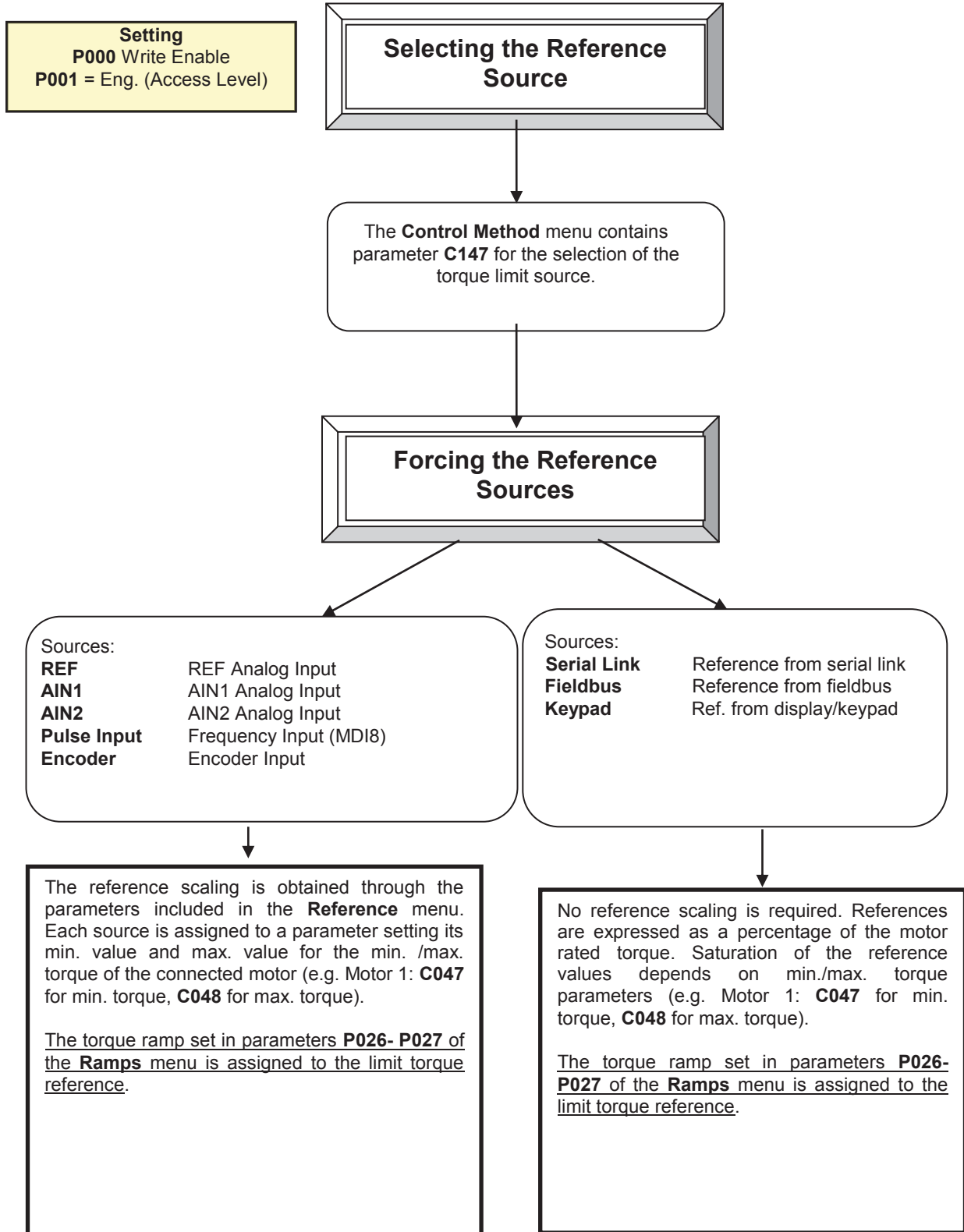

5.4. Configuring the Feedback from Incremental Encoder

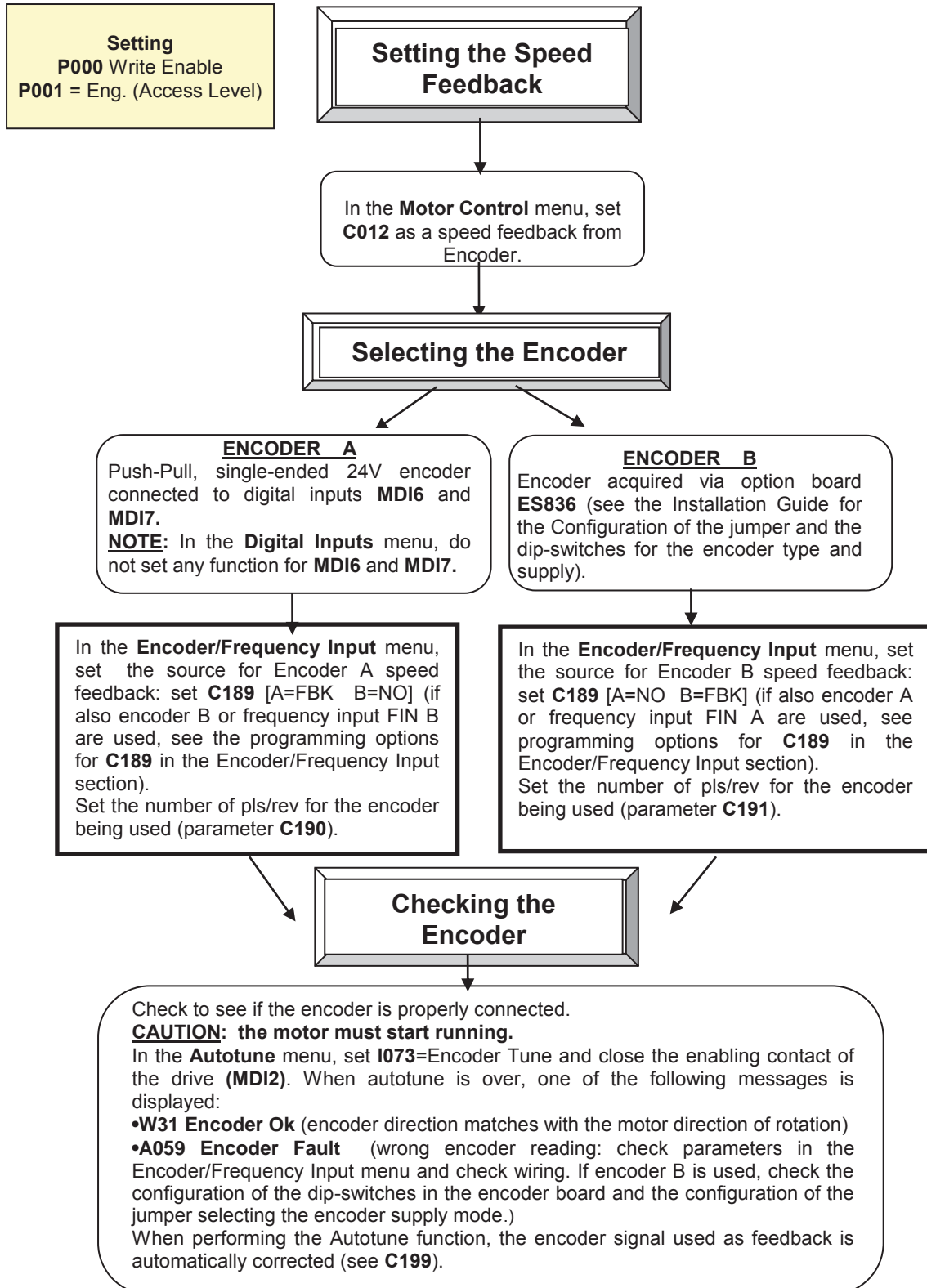

5.5. Configuring a Reference from Incremental Encoder

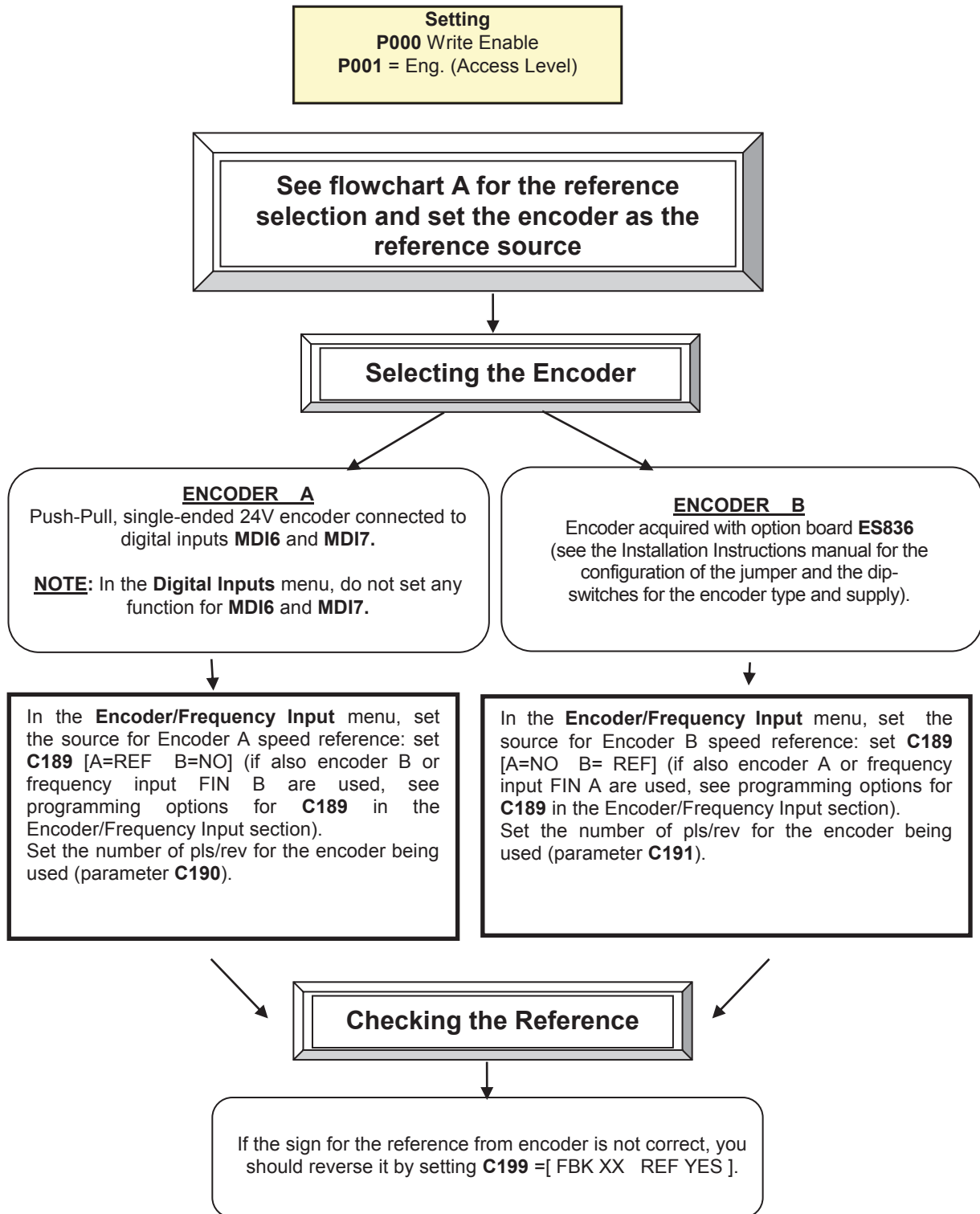

6. START-UP MENU

6.1. Overview

For easier startup of the Penta drive, you can activate the Start-Up Menu. The Start-Up Menu is a wizard allowing programming the main parameters for the connected motor and the parameters for PID control. The parameters in this menu are the same as described in the FIRST STARTUP section.

The Start-Up Menu is displayed when the Penta drive is first started. The Start-Up Menu can be reactivated at any time. To do so, set **P265** in “Start Up” mode (see the DISPLAY/KEYPAD MENU) and power on the Penta drive again.

The following is the root page of the Start-Up menu:

```
[ I D P ] S I N U S   P E N T A
S T A R T - U P   M E N U
P r e s s   E N T E R
t o   s t a r t
```

Press **ENTER** to enter the wizard.

Before entering the control parameters, you are asked to choose a dialogue language:

```
P 2 6 3   L a n g u a g e
→@@@@@@@@@@@@@@@@
```

then you are asked to choose the display mode of the Start Up Menu:

```
W h e n   d o e s   t h e
S t a r t - U p   M e n u
a c t i v a t e ?
→@@@@@@@@@@@@@@@@
```

Choose one of the following:

```
1 : E V E R Y   S T A R T - U P
2 : O N L Y   N O W
3 : N E X T   S T A R T - U P
4 : N E V E R
```

If you select “EVERY START-UP”, the wizard appears whenever the Penta drive is powered on;
if you select “ONLY NOW”, you can scroll through the menu and the wizard is disabled as soon as you quit the menu;
if you select “NEXT START-UP”, the menu is displayed only when the Penta drive is next started up;
if you select “NEVER”, the Start-Up menu is disabled.



Parameters included in the Start-Up menu:

Parameter	Description	Visibility
C008	Rated mains voltage	
C010	Type of control algorithm	
C012	Speed feedback from encoder	[only if FOC is active]
C013	Type of V/f pattern	[only if IFD is active]
C015	Rated motor frequency	
C016	Rated motor rpm	
C017	Rated motor power	
C018	Rated motor current	
C019	Rated motor voltage	
C021	No-load current of the motor	[only if FOC is active]
C028	Min. motor speed	
C029	Max. motor speed	
C034	Voltage preboost	[only if IFD is active]
P009	Acceleration ramp time	
P010	Deceleration ramp time	
C043	Current limit while accelerating	[only if IFD is active]
C044	Current limit at constant rpm	[only if IFD is active]
C045	Current limit while decelerating	[only if IFD is active]
C048	Torque limit	[only if VTC/FOC are active]
C189	Encoder operating mode	[only if FOC is active]
C190	Encoder A pls/rev	[only if FOC is active]
C191	Encoder B pls/rev	[only if FOC is active]
I073	Autotune selection	[only if VTC/FOC are active]
I074	Motor tuning selection	[only if VTC/FOC are active]
C265	Motor thermal protection	
C267	Motor thermal time constant	[only if protection is active]

After setting the last parameter and moving the cursor forward, the following page will appear:

P r e s s U P A R R O W
t o q u i t
D O W N A R R O W
t o c o n t i n u e

Press ▲ to quit the Start-up menu. The default page of the system will be displayed.

7. FIRST STARTUP

For the signal wiring and power wiring, please refer to the Sinus Penta's Installation Guide. Parameter programming is detailed in the START-UP MENU.

7.1. "IFD" Control Algorithm

SINUS PENTA drives are factory set with the IFD (**C010**) control algorithm for the first startup of the equipment. The default functions of the drive terminals are given in the table below. For more details, please refer to the Sinus Penta's Installation Guide.

- 1) Wiring:** Follow the instructions stated in the "Caution Statements" and "Installation" sections (Installation Guide).
- 2) Power on:** Power on the drive and do not close the link to the **ENABLE-A** and **ENABLE-B** inputs to prevent the motor from running. Check if the display/keypad turns on.
- 3) Parameter setting:** The equipment startup is made easier by the START-UP MENU, which is a wizard for the set-up of the main motor control parameters.

From the START-UP MENU, set the following:

1. The actual power supply voltage in **C008**. It is possible to select the rated mains voltage range or the power supply from a DC-bus stabilized by a Regenerative Penta;
2. The motor ratings by way of:
 - **C015** (fmot1) rated frequency
 - **C016** (rpmnom1) rated rpm
 - **C017** (Pmot1) rated power
 - **C018** (Imot1) rated current
 - **C019** (Vmot1) rated voltage
 - **C029** (Speedmax1) max. allowable speed.

The motor V/f pattern may be programmed in **C013**. For loads with quadratic torque in respect to the rpm (centrifugal pumps, fans, etc.), set **C034** (preboost1) to 0%.

- 4) Autotune (motor stopped):** In case of IFD motor control when slip compensation is inactive (**C039**=0%) no autotune is required. On the other hand, when slip compensation is active, it is recommended to compute stator resistance **C022**.

The steps to take to perform motor autotune are the following:

With the **ENABLE-A** and **ENABLE-B** commands open, access the AUTOTUNE MENU and set **I073** = [1: Motor Tune] and **I074** = [0: All Ctrl no rotation]. Use the **ESC** key to accept changes.

Close the **ENABLE-A** and **ENABLE-B** commands and wait until tune is complete (Warning "**W32** Open Enable" is displayed). The drive has computed and saved the values for **C022** (stator resistance).

If alarm "**A097** Motor Wires KO" trips, check the motor wiring. If alarm "**A065** Autotune KO" trips, this means that the **ENABLE** command has opened before autotune was complete. In this case, reset the drive by sending a command from terminal MDI3, or press the **RESET** key in the display/keypad and perform the autotune procedure again.

- 5) Overload:** Set parameters **C043**, **C044** and **C045** as the maximum desired overload current.

**6) Startup:**

Activate the **ENABLE-A** input (terminal 15), **ENABLE-B** input (terminal S) and the **START** input (terminal 14) and send a speed reference: the **RUN LED** and **REF LED**s will come on and the motor will start running. Make sure that the motor is rotating in the correct direction. If not, set parameter **C014** (Phase Rotation) to [1:Yes], or open the **ENABLE-A**, **ENABLE-B** and **START** inputs, remove voltage from the drive and, after waiting at least 20 minutes, swap two of the motor phases.

7) Possible failures: If no failure occurred, go to step **8**). Otherwise, check the drive connections paying particular attention to supply voltages, DC link and input reference. Also check if alarm messages are displayed. In the MEASURES MENU, check the reference speed (**M001**), the supply voltage to the control section (**M030**), the DC link voltage (**M029**), and the condition of control terminals (**M033**). Check to see if these readouts match with the measured values.

8) Additional parameter modifications: When parameter **P003** = Standby Only (condition required for changing C parameters), you can change **Cxxx** parameters in the CONFIGURATION menu only when the drive is DISABLED or STOPPED, whereas if **P003** = Standby + Fluxing, you can change **Cxxx** parameters when the motor is stopped but the drive is enabled.

You can write down any custom parameters in the table provided on the last pages of this Programming Guide (CUSTOM PARAMETERS).

9) Reset: If an alarm trips, find the cause responsible for the alarm and reset the drive. Enable input MDI3 (terminal 16) for some time, or press the **RESET** key on the display/keypad.



NOTE When the IFD control algorithm is used, only speed references can be set up.



NOTE The **ENABLE-A** and **ENABLE-B** inputs are allocated to the STO function. If this safety function is to be adopted, the control mode and the control circuit of these signals must be accomplished as per the Safe Torque Off Function - Application Manual. That manual also includes a detailed validation procedure of the control configuration of the STO function to be executed upon first start-up and also periodically at yearly intervals.

7.2. “VTC” Control Algorithm

- 1) Wiring:** Follow the instructions stated in the “Caution Statements” and “Installation” sections in the Sinus Penta’s Installation Guide.
- 2) Power on:** Power on the drive and do not close the link to the **ENABLE-A** and **ENABLE-B** inputs to prevent the motor from running. Check if the display/keypad turns on.
- 3) Parameter setting:** The equipment startup is made easier by the START-UP MENU, which is a wizard for the setup of the main motor control parameters.
- From the START-UP MENU, set the following:
1. The actual power supply voltage in **C008**. It is possible to select the rated mains voltage range or the power supply from a DC-bus stabilized by a Regenerative Penta;
 2. The control algorithm as VTC (Vector Torque Control) in **C010**;
 3. The motor ratings by way of:
 - **C015** (fmot1) rated frequency
 - **C016** (rpmnom1) rated rpm
 - **C017** (Pmot1) rated power
 - **C018** (Imot1) rated current
 - **C019** (Vmot1) rated voltage
 - **C029** (Speedmax1) max. allowable speed.



CAUTION: It is not advisable to set rated motor power and current lower than 50% of the drive size. This would adversely affect the motor control performance.

- 4) Setting no-load current C021** If the motor current is known, set **C021** (I_0) to the value of I_0 expressed as a percentage of the rated motor current.
- If the no-load current of the motor is not known but the motor can rotate freely without any connected load, start the motor in IFD mode at nominal rpm, read out the current value from the Motor Measures Menu and use that value as the first trial value for I_0 . For example, if the rated motor current is **C018** = 133A and **M026** = 36A, set **C021** = $36/133=27\%$.



NOTE: If the motor must run at a higher speed than the rated speed (field weakening mode) read out the no-load current value at rated speed in any case.

Lastly, if the no-load current of the motor is not known and the motor cannot rotate under no-load conditions, you can use the first I_0 trial value automatically computed by the Penta drive during the tuning procedure described in step 5).



NOTE: Each time the tuning procedure in step 5) is carried out with no-load current parameter **C021** (I_0) = 0, the Penta drive will automatically enter a value based on the motor current ratings.

- 5) Autotune of motor parameters (motor stopped)** With the **ENABLE-A** and **ENABLE-B** commands open, access the AUTOTUNE MENU and set **I073**=[1: Motor Tune] and **I074**=[0: Motor Params]. Press **ESC** to confirm the new values.
- Close the **ENABLE-A** and **ENABLE-B** commands and wait until tune is complete (Warning “**W32** Open Enable” is displayed).

The drive has now computed and saved the following parameter values:

- **C022** (stator resistance) through motor measurements
- **C023** (leakage inductance) through motor measurements
- If **C021**=0, a first trial value for no-load current **C021** is computed based on the motor ratings

- **C024** (mutual inductance)
- If **C025=0**, a first trial value for rotor time constant **C025** is computed based on the motor ratings

If alarm “**A097** Motor Wires KO” trips, check the motor wiring. If alarm “**A065** Autotune KO” trips, this means that the **ENABLE-A** and **ENABLE-B** commands have opened before autotune was complete. In that case, reset the drive sending a command from terminal MDI3, or press the **RESET** key in the display/keypad and perform the autotune procedure again.

If the motor can rotate with no connected load, carry out the autotune procedure for the rotor time constant and the current loop of the VTC regulator as detailed in step **6a**), otherwise carry out only the current loop tuning as detailed in step **6b**) (in that case, the rotor time constant **C025** is not computed based on the motor measurements).

6a) Autotune for rotor time constant and current loop (rotor free)



CAUTION: This type of tuning requires that the motor is free to rotate with no connected load. During autotune, current is first applied to the motor when the rotor is not running, then the motor is operated to run at approx. 70% of its rated speed.

If the motor can rotate with no connected load, with the **ENABLE-A** and **ENABLE-B** commands open, access the AUTOTUNE MENU and set **I073=** [1: Motor Tune] e **I074=** [2: Control YES rot]. Press **ESC** to confirm the new values.

Close the **ENABLE-A** and **ENABLE-B** commands and wait until tune is complete (Warning “**W32** Open Enable” is displayed).

The drive has now computed and saved the following parameter values:

- **C025** (rotor time constant) through motor measurements
- **P175t1** (proportional gain of the current control) and **P175u1** (integral time of the current control) through motor measurements.

If alarm “**A065** Autotune KO” trips, this means either that the **ENABLE-A** and **ENABLE-B** commands have opened before autotune was complete, or that the available timeout has elapsed. In either case, reset the drive sending a command from terminal MDI3, or press the **RESET** key on the display/keypad and perform the autotune procedure again.



NOTE: If autotune has not been interrupted by opening the **ENABLE-A** and **ENABLE-B** commands, decrease no-load current value **C021** by 5% before performing the autotune procedure again.

6b) Current loop autotune (motor stopped):

If the motor cannot rotate with any connected load, it is not possible to estimate the rotor time constant by way of the autotune procedure. Therefore, only the VTC current loop is tuned.

With the **ENABLE-A** and **ENABLE-B** commands open, access the AUTOTUNE MENU and set **I073=** [1: Motor Tune] and **I074=** [1: Control NO rot]. Press **ESC** to confirm the new changes. Close the **ENABLE-A** and **ENABLE-B** commands and wait until tune is complete (Warning “**W32** Open Enable” is displayed).

The drive has now computed and saved the following parameter values:

- **P175t1** (proportional gain of the current control) through motor measurements.
- **P175u1** (integral time of the current control) through motor measurements.

If alarm “**A065** Autotune KO” trips, this means that the **ENABLE-A** and **ENABLE-B** commands have opened before autotune was complete or the autotune algorithm has failed within the preset timeout. In that case, reset the drive sending a command from terminal MDI3, or press the **RESET** key in the display/keypad and perform the autotune procedure again.



- 7) Overload:** Set parameter **C048** in the LIMITS MENU based on the maximum torque that can be generated expressed as a percentage of the motor rated torque.

- 8) Start up:** Activate the **ENABLE-A** input (terminal 15), **ENABLE-B** (terminal S) and the **START** input (terminal 14) and send a speed reference. The **RUN** LED and **REF** LED will come on and the motor will start. Make sure that the motor is rotating in the correct direction. If not, set parameter **C014** (Phase Rotation) = [1:Yes], or open the **ENABLE-A**, **ENABLE-B** and **START** inputs, remove voltage from the drive and, after waiting at least 20 minutes, swap two of the motor phases.

- 9) Speed regulator adjustment:** If overshoot occurs when the speed setpoint is attained or if a system instability is detected (jerking), adjust the parameters relating to the speed loop (SPEED LOOP AND CURRENT BALANCING MENU). Set the two parameters relating to integral time (**P125**, **P126**) as [Disabled] and set low values for the parameters relating to proportional gain (**P128**, **P129**). Set equal values for **P128** and **P129** and increase them equally until overshoot takes place when the setpoint is attained. Decrease **P128** and **P129** by approx. 30%, then decrease the high values set for integral time in **P125** and **P126** (keep both values equal) until an acceptable setpoint response is obtained. Check to see if the motor runs smoothly at constant speed.

- 10) Possible failures:** If no failure occurred, go to step **11**). Otherwise, check the drive connections paying particular attention to supply voltages, DC link and input reference. Also check if alarm messages are displayed. In the MEASURES MENU, check the reference speed (**M000**), the reference speed processed by the ramps (**M002**), the supply voltage of the control section (**M030**), the DC-link voltage (**M029**), the condition of the control terminals (**M033**). Check to see if these readouts match with the measured values.

- 11) Additional parameter modifications:** If the motor control is underperforming, make sure that the following measurements are consistent with the expected motor operation:
 - estimated speed **M004** in respect to speed ramp **M002**,
 - output frequency **M006**,
 - generated torque **M012** in respect to torque demand **M011**,
 - output current **M026**,
 - output voltage **M027**.

Proceed as follows:

Issue	What to do
Generation of weak torque or inaccurate torque delivery	Increase the flux boost at low frequency P175h1 and adjust the frequency range for the boost to occur via parameters P175i1 and P175j1 . The magnetization current at low frequency with active current boost equals the no-load current value in C021 increased by the value in P175h1 (for example, if C021 =27% and P175h1 =30%, the magnetization current is 27% \times 1.3=35.1%). Up to the frequency value in P175i1 , the magnetization current is C021 \times (1+ P175h1); at a frequency higher than P175j1 , the magnetization current is C021 ; at intermediate frequency values, the magnetization current follows a linear pattern. Too high magnetization current values may lead to saturation of the motor flux, lower efficiency due to greater no-load current, inaccurate torque adjustment or controller instability. It is suggested that P175j1 be applied at its maximum value up to 50% of the rated frequency. Also, set P175i1 in such a way so as to obtain a rather smooth pattern (for example, P175i1 set to half the value in P175j1). In case P175i1 and P175j1 are not correctly adjusted, torque adjustment may be uneven or current variations may occur.
Generation of weak torque at high speed	If the motor is not capable of delivering high torque at high speed (close to rated torque or field weakening torque) or requires excessive current in respect to the expected current, it is possible to adjust rotor time constant C025 .
Generation of weak torque at low speed or in	Change current distortion compensation parameters in VTC control P175a , P175b , P175c . Change current distortion

regenerative mode	compensation P175b first, then change positive and negative current split P175c . For high values in P175b , also increase the linear pattern threshold in P175a . If parameter P175b is set too high or P175a is set too low, rotor oscillations may occur, or it may happen that the rotor is not kept standstill even in no-load conditions. If this is the case, set lower values for the parameters above.
Low output voltage or weak torque in field weakening mode	Disable static field weakening by setting C030 = Disable and enable automatic field weakening by setting C030a >0. In that way, the field weakening amplitude is automatically adjusted to ensure adjusting the required speed at the maximum allowable voltage fitting the rated motor voltage and the available DC voltage.
Generated torque (measure M012) note different from torque demand (measure M011)	It is required for certain applications that the generated torque is as close as possible to the torque demand; this is due to the fact that the torque limitation (parameters C047 and C048) operates on the torque demand, thus it is important that the generated torque is limited correctly. To do so, it is necessary to: <ul style="list-style-type: none"> • Verify M011 and M012 in normal working conditions of the motor and, or in any case, at least at 75% of the rated speed with at least 75% of the rated load. If the motor must run at a higher speed than rated speed (weakening field mode) verify the parameters in this condition as well. • If M011>M012, gradually increase C023 at a rate of around 10%. • If M011<M012, gradually decrease C023 at a rate of around 10%. • In the event that, increasing C023, difficulties in the starting phase arise, gradually decrease C024 at a rate of around 10% and find a new value for C023 to make M011 and M012 equivalent.

When parameter **P003** = Standby Only (condition required for changing **Cxxx** parameters), you can change **Cxxx** parameters only when the drive is DISABLED or STOPPED, whereas if **P003** = Standby + Fluxing, you can change **Cxxx** parameters when the motor is stopped but the drive is enabled.

Before changing any parameters, remember that the correct code for parameter **P000** must be previously set up.

You can write down any custom parameters in the table provided on the last pages of this Programming Manual (CUSTOM PARAMETERS).

12) Reset:

If an alarm trips, find the cause responsible for the alarm and reset the drive. Enable input MDI3 (terminal 16) for some time, or press the **RESET** key on the display/keypad.



NOTE

The **ENABLE-A** and **ENABLE-B** inputs are allocated to the STO function. If this safety function is to be adopted, the control mode and the control circuit of these signals must be accomplished as per the Safe Torque Off Function - Application Manual. That manual also includes a detailed validation procedure of the control configuration of the STO function to be executed upon first start-up and also periodically at yearly intervals.

7.3. “FOC” Control Algorithm

- 1) Wiring:** Follow the instructions stated in the “Caution Statements” and “Installation” sections in the Installation Guide.
- 2) Power on:** Power on the drive and do not close the link to the **ENABLE-A** and **ENABLE-B** inputs to prevent the motor from running. Check to see if the display/keypad turns on.
- 3) Parameter setting:** The equipment startup is made easier by the START-UP MENU, which is a wizard for the set-up of the main motor control parameters.
- From the START-UP MENU, set the following:
1. The actual power supply voltage in **C008**. It is possible to select the rated mains voltage range or the power supply from a DC-bus stabilized by a Regenerative Penta;
 2. Control algorithm as FOC (Field Oriented Control) in **C010**;
 3. The motor ratings by way of:
 - **C015** (fmot1) rated frequency
 - **C016** (rpmnom1) rated rpm
 - **C017** (Pmot1) rated power
 - **C018** (Imot1) rated current
 - **C019** (Vmot1) rated voltage
 - **C029** (Speedmax1) max. allowable speed.



CAUTION: It is not advisable to set rated motor power and current lower than 50% of the drive size. This would adversely affect the motor control performance.

4) Setting no-load current C021

If the no-load current of the motor is known, set **C021** (I_0) with the I_0 value expressed as a percentage of the rated motor current.

If the no-load current of the motor is not known but the motor can rotate freely without any connected load, start the motor in IFD mode at nominal rpm, read out the current value from the Motor Measures Menu (**M026**) and use it as a first trial value for I_0 . For example, if the rated current is **C018** = 133A and **M026** = 36A, set **C021** = $36/133=27\%$.



NOTE: If the motor must run at a higher speed than the rated speed (field weakening mode) read out the no-load current value at rated speed in any case.

Lastly, if the no-load current of the motor is not known and the motor cannot rotate under no-load condition, you can use the first I_0 trial value automatically computed by the Penta drive during the tuning procedure described in step 6).



NOTE: Each time the tuning procedure in step 5) is carried out with no-load current parameter **C021** (I_0) = 0, the Penta drive will automatically enter a value based on the motor current ratings.

5) Encoder test:

The motor must run when testing the encoder.

Set the source of the encoder signal used as a speed feedback (Encoder A in terminal board, Encoder B from ES836 or ES913 optional board) in parameter **C189**; enter the number of pulse/rev (**C190** or **C191**).

Set the parameter relating to speed feedback from encoder: **C012** = Yes.

With the **ENABLE-A** and **ENABLE-B** commands open, access the AUTOTUNE MENU and set parameter **I073**=[2: Encoder Tune]. Use the **ESC** key to confirm changes. Close the **ENABLE-A** and **ENABLE-B** commands and wait until encoder tune is complete (“**W32** Open Enable” is displayed).

Once encoder tune is complete, the display will show one of the following messages:

“**W31** Encoder Ok”; the speed feedback is correct. If the speed detected by the encoder is opposite to the desired speed, the drive will automatically reverse the feedback sign (parameter **C199**).

“**A059** Encoder Fault”; the speed detected from the encoder is not consistent with the control speed. Possible causes:

- Wrong number of pls/rev of the encoder
- Wrong power supply of the Encoder (e.g. +5V instead of +24V): check the encoder ratings and the position of jumpers and DIP-switches for the encoder supply in the optional encoder board
- Wrong configuration of the DIP-switches for the encoder selection (push-pull or line-driver encoder) in the optional encoder board
- No connection to the encoder channel (check wiring)
- At least one Encoder channel is faulty (replace the encoder).

6) Motor tuning parameters (motor stopped)

With the **ENABLE-A** and **ENABLE-B** commands open, access the AUTOTUNE MENU and set **I073**=[1: Motor Tune] and **I074**=[0: Motor Params]. Press **ESC** to confirm the new values.

Close the **ENABLE-A** and **ENABLE-B** commands and wait until tune is complete (Warning “**W32** Open Enable” is displayed).

The drive has now computed and saved the following parameter values:

- **C022** (stator resistance) through motor measurements
- **C023** (leakage inductance) through motor measurements
- If **C021**=0, a first trial value for no-load current **C021** is computed based on the motor ratings
- **C024** (mutual inductance)
- If **C025**=0, a first trial value for rotor time constant **C025** is computed based on the motor ratings

If alarm “**A097** Motor Wires KO” trips, check the motor wiring. If alarm “**A065** Autotune KO” trips, this means that the **ENABLE-A** and **ENABLE-B** commands have opened before autotune was complete. In that case, reset the drive sending a command from terminal MDI3, or press the **RESET** key in the display/keypad and perform the autotune procedure again.

If the motor can rotate with no connected load, carry out the autotune procedure for the rotor time constant and the current loop of the FOC regulator as detailed in step **7a**), otherwise carry out only the current loop tuning as detailed in step **7b**) (in that case, the rotor time constant **C025** is not computed based on the motor measurements).

7a) Autotune of the rotor time constant and current and flux loops (rotor free)



CAUTION: This type of tuning requires that the motor is free to rotate with no connected load. During autotune, current is first applied to the motor when the rotor is not running, then the motor is operated to run at approx. 70% of its rated speed.

If the motor can rotate with no connected load, with the **ENABLE-A** and **ENABLE-B** commands open, access the AUTOTUNE MENU and set **I073**= [1: Motor Tune] e **I074**= [2: Control YES rot]. Press **ESC** to confirm the new values.

Close the **ENABLE-A** and **ENABLE-B** commands and wait until tune is complete (Warning "**W32** Open Enable" is displayed).

The drive has now computed and saved the following parameter values:

- **C025** (rotor time constant) through motor measurements
- **P155** (proportional gain of the current control) and **P156** (integral time of the current control) through motor measurements.
- **P158** (proportional gain of the flux control) and **P159** (integral time of the flux control) based on the rotor time constant.

If alarm "**A065** Autotune KO" trips, this means that the **ENABLE-A** and **ENABLE-B** commands have opened before autotune was complete or the autotune algorithm has failed within the preset timeout. In that case, reset the drive sending a command from terminal MDI3, or press the **RESET** key in the display/keypad and perform the autotune procedure again.



NOTE: If autotune has not been interrupted by opening the **ENABLE-A** and **ENABLE-B** commands, decrease no-load current value **C021** by 5% before performing the autotune procedure again.

7b) Autotune of the current and flux loops (motor stopped)

If the motor cannot rotate with any connected load, it is not possible to estimate the rotor time constant by way of the autotune procedure, therefore, only the VTC current loop is tuned.

With the **ENABLE-A** and **ENABLE-B** commands open, access the AUTOTUNE MENU and set **I073**= [1: Motor Tune] and **I074**= [1: Control NO rot]. Press **ESC** to confirm the new changes. Close the **ENABLE-A** and **ENABLE-B** commands and wait until tune is complete (Warning "W32 Open Enable" is displayed).

The drive has now computed and saved the following parameter values:

- **P155** (proportional gain of the current control) and **P156** (integral time of the current control) through motor measurements.
- **P158** (proportional gain of the flux control) and **P159** (integral time of the flux control) based on the rotor time constant.

If alarm "A065 Autotune KO" trips, this means that the **ENABLE-A** and **ENABLE-B** commands have opened before autotune was complete or the autotune algorithm has failed within the preset timeout. In that case, reset the drive sending a command from terminal MDI3, or press the **RESET** key in the display/keypad and perform the autotune procedure again.

8) Overload:

Set parameter **C048** in the LIMITS MENU based on the maximum torque that can be generated expressed as a percentage of the motor rated torque.

9) Start up:

Activate the **ENABLE-A** input (terminal 15), **ENABLE-B** (terminal S) and the **START** input (terminal 14) and send a speed reference. The **RUN** LED and **REF** LED will come on and the motor will start. Make sure that the motor is rotating in the correct direction. If not, set parameter **C014** (Phase Rotation) = [1:Yes], or open the **ENABLE-A**, **ENABLE-B** and **START** inputs, remove voltage from the drive and, after waiting at least 20 minutes, swap two of the motor phases.

10) Speed regulator adjustment:

If overshoot occurs when the speed setpoint is attained or if a system instability is detected (jerking), adjust the parameters relating to the speed loop (SPEED LOOP AND CURRENT BALANCING MENU). Set the two parameters relating to integral time (**P125**, **P126**) as [Disabled] and set low values for the parameters relating to proportional gain (**P128**, **P129**). Set equal values for **P128** and **P129** and increase them equally until overshoot takes place when the setpoint is attained. Decrease **P128** and **P129** by approx. 30%, then decrease the high values set for integral time in **P125** and **P126** (keep both values equal) until an acceptable setpoint response is obtained. Check to see if the motor runs smoothly at constant speed.

11) Possible failures:

If alarm "A060 Fault No Curr." trips, this means that the current loop is not properly tuned. Follow the instructions given in step **6**) and decrease the value of I_0 (parameter **C021** in the MOTOR CONFIGURATION MENU).

If the motor is noisy when starting, this means that the rotor time constant is not correct. Follow the instructions given in step **7a)** or **7b)** again, or manually change the value of the rotor time constant (parameter **C025**) for a smooth motor startup.

If no failure occurred, go to step **7)**. Otherwise, check the drive connections paying particular attention to supply voltages, DC link and input reference. Also check if alarm messages are displayed. In the Motor Measures Menu, check the speed reference (**M000**), the reference speed processed by the ramps (**M002**), the supply voltage of the control section (**M030**), the DC link voltage (**M029**), the condition of the control terminals (**M033**). Check to see if these readouts match with the measured values.

**12) Additional
parameter
modifications:**

For the optimization of the motor performance, adjust parameters **C021** (no-load current), **C024** (mutual inductance), **C025** (rotor time constant). Consider the following:

- **C021 Too high values** → Lower torque, especially at rated speed, because most part of the voltage imposed by the drive is used to magnetize the motor instead of generating a proper motor torque;
- **C021 Too low values** → Because of the motor flux weakening, higher current ratings are needed;
- **C024 Mutual inductance** → This is computed each time the no-load current level is changed. This is not binding for the motor control, but strongly affects the correct estimation of the output torque; in case of overestimation, decrease **C024**, and vice versa;
- **C025 Optimum value** → To obtain the optimum value of the rotor time constant, the best way consists in performing several attempts with a constant load but with different values of **C025**. The optimum value is the one ensuring to obtain the output torque with the lower current (see **M026**).

When parameter **P003** = Standby Only (condition required for changing C parameters), you can change **Cxxx** parameters in the CONFIGURATION menu only when the drive is DISABLED or STOPPED, whereas if **P003** = Standby + Fluxing, you can change **Cxxx** parameters when the motor is stopped but the drive is enabled. You can write down any custom parameters in the table provided on the last pages of this Programming Guide (CUSTOM PARAMETERS).

12) Reset:

If an alarm trips, find the cause responsible for the alarm and reset the drive. Enable input MDI3 (terminal 16) for some time, or press the **RESET** key on the display/keypad.

NOTE

The **ENABLE-A** and **ENABLE-B** inputs are allocated to the STO function. If this safety function is to be adopted, the control mode and the control circuit of these signals must be accomplished as per the Safe Torque Off Function - Application Manual. That manual also includes a detailed validation procedure of the control configuration of the STO function to be executed upon first start-up and also periodically at yearly intervals.

8. MEASURES MENU

8.1. Overview

The Measures Menu contains the variables measured by the drive that can be used by the user. In the display/keypad, measures are divided into subgroups. The measure subgroups are the following:

Motor Measures Menu

This menu contains: the values of the speed reference at constant rpm, the values of the reference being used and the speed values of the connected motor expressed in rpm; the drive rated frequency; the torque reference at constant rpm, the torque demand and the motor torque output, the torque limit reference at constant speed and the torque limit being used expressed both in Nm and as a percentage of the rated torque of the selected motor; the flux reference and the electrical variables measured by the drive mains side, the DC-bus and output; the measures of the incremental or absolute encoders being used.

PID Controller Menu

This menu contains the values relating to the PID controller of the Penta drive.

Digital Inputs Menu

This menu contains the state of the drive digital inputs and the indication of the functions programmed for the digital inputs of the Penta drive.

References Menu

This menu contains the following values: analog references, the encoder input and the frequency input references, the speed/torque or reference/feedback values of the PID coming from serial link or fieldbus.

Outputs Menu

This menu contains the state of the drive digital outputs, analog outputs and frequency outputs.

Temperatures from PT100 Menu

This menu contains the temperature values detected in the first four analog channels of ES847 I/O expansion board (this menu is available only if ES847 is fitted).

Autodiagnosics Menu

This menu contains the temperature values, the operation time counter and the supply time counter, the active alarm and the drive status.

Data Logger Measures Menu

This menu contains the status of the type of connections (serial links, Ethernet and modem) supported by ES851 Data Logger board (this menu is available only if the Data Logger ES851 is fitted).

Digital Input Settings Menu

This menu contains the functions assigned to the digital inputs.

Fault List Menu

This menu contains the trip log of the last eight alarms tripped and the values of some measures being used when the alarm trip was stored.

PowerOff Log Menu

This menu contains the value of some measures being used at the drive power off.

8.2. Motor Measures Menu

This menu contains speed values, torque values and electrical variables measured by the drive on the mains side, DC bus and output.

M000 Speed Reference at Constant RPM

M000-1	Range	± 32000 (integer part) ± 99 (decimal part)	± 32000.99 rpm <u>Note:</u> The actual range depends on the selected motor, because it is defined by the value set in the parameters for the motor max. speed and min. speed. C028–C029 Motor 1 C071–C072 Motor 2 C114–C115 Motor 3
	Active	Active only when a speed reference is used for the selected motor.	
	Address	1650 (integer part) 1651 (decimal part)	
	Function	Value of the speed reference obtained when the motor rotates at constant speed, once the preset ramp time is over.	

M002 Speed Ramp Output

M002-3	Range	± 32000 (integer part) ± 99 (decimal part)	± 32000.99 rpm <u>Note:</u> The actual range depends on the selected motor, because it is defined by the value set in the parameters for the motor max. speed and min. speed. C028–C029 Motor 1 C071–C072 Motor 2 C114–C115 Motor 3
	Active	Active only when a speed reference is used for the selected motor.	
	Address	1652 (integer part) 1653 (decimal part)	
	Function	This is the measure of the speed value processed with respect to the ramp time.	

M004 Motor Speed

M004-5	Range	± 32000 (integer part) ± 99 (decimal part)	± 32000.99 rpm <u>Note:</u> it is possible to set a customized unit of measure and a customized scaling for measure M004u .
	Active	Always active. Decimal part active for FOC control only.	
	Address	1654 (integer part) 1655 (decimal part)	
	Function	Motor speed value.	

M006 Drive Output Frequency

M006	Range	± 10000	± 1000.0 Hz (see Table 70)
	Active	Always active.	
	Address	1656	
	Function	This is the measure of the voltage frequency output of the drive.	

M007 Torque Reference at Constant Speed (Nm)

M007	Range	± 32000	± 32000 Nm <u>Note:</u> The actual range depends on the torque limit values set for the selected motor. C047–C048 Motor 1 C090–C091 Motor 2 C133–C134 Motor 3
	Active Address	Active only when a torque reference is used for the selected motor. 1657	
	Function	This is the measure of the torque reference required at constant speed and expressed in Nm.	

M008 Torque Demand (Nm)

M008	Range	± 32000	± 32000 Nm <u>Note:</u> The actual range depends on the rated torque and the torque limit values set for the selected motor. C047–C048 Motor 1 C090–C091 Motor 2 C133–C134 Motor 3
	Active Address	Active for VTC and FOC controls only. 1658	
	Function	<u>With speed control:</u> Torque demand of the speed regulator for the type of control used. <u>With torque control:</u> Torque reference processed in respect to the preset torque ramp time.	

M009 Torque Generated by the Motor (Nm)

M009	Range	± 32000	± 32000 Nm <u>Note:</u> it is possible to set a customized unit of measure and a customized scaling for measure M009u .
	Active Address	Active for VTC and FOC controls only. 1659	
	Function	Estimated value of the torque produced by the connected motor.	

M010 Torque Reference at Constant RPM (%)

M010	Range	± 500	± 500 % <u>Note:</u> The actual range depends on the torque limit values set for the selected motor. C047–C048 Motor 1 C090–C091 Motor 2 C133–C134 Motor 3
	Active Address	Active only when a torque reference is used for the selected motor. 1660	
	Function	This is the measure of the torque reference required at constant speed and expressed as a percentage of the motor rated torque.	

M011 Torque Demand (%)

M011	Range	± 500	± 500 % <u>Note:</u> The actual range depends on the torque limit values set for the selected motor. C047–C048 Motor 1 C090–C091 Motor 2 C133–C134 Motor 3
	Active	Active for VTC and FOC controls only.	
	Address	1661	
	Function	<u>With speed control:</u> Torque demand of the speed regulator expressed as a percentage of the motor rated torque. <u>With torque control:</u> Torque reference processed with respect to the preset torque ramp time and expressed as a reference of the motor rated torque.	

M012 Torque Generated by the Motor (%)

M012	Range	± 500	± 500 %
	Active	Active only for VTC and FOC controls.	
	Address	1662	
	Function	Estimated value of the torque produced by the motor and expressed as a percentage of the rated torque of the selected motor.	

M013 Torque Limit Demand before Ramps (Nm)

M013	Range	± 32000	± 32000 Nm <u>Note:</u> The actual range depends on the preset torque limit values and the rated torque of the selected motor. C047–C048 Motor 1 C090–C091 Motor 2 C133–C134 Motor 3
	Active	Active for VTC and FOC controls only.	
	Address	1663	
	Function	This is the limit value for the torque at constant speed. If an external torque limit is used, the value of this measure is the torque limit obtained at constant speed; on the other hand, if the torque limit is internal to the drive, this value is the actual torque limit expressed in Nm.	

M014 Torque Limit Demand after Ramps (Nm)

M014	Range	± 32000	± 32000 Nm <u>Note:</u> The actual range depends on the preset torque limit values and the rated torque of the selected motor. C047–C048 Motor 1 C090–C091 Motor 2 C133–C134 Motor 3
	Active	Active for VTC and FOC controls only.	
	Address	1664	
	Function	This is the torque limit value being used, expressed in Nm.	

M013a Speed Limit before the Ramps

M013a	Range	± 32000	± 32000 rpm
	Active	Active for FOC only.	
	Address	1726	

	Function	Limit value at constant speed of the motor speed of rotation in “torque control with speed limit” mode (C011=2 for Motor 1; C054, C097 for Motors 2 and 3).	
--	-----------------	---	--

M014a Speed Limits after the Ramps

M014a	Range	± 32000	± 32000 rpm
	Active	Active for FOC only.	
	Address	1727	
	Function	Current limit value of the motor speed of rotation in “torque control with speed limit” mode (C011 =2 for Motor 1; C054 , C097 for Motors 2 and 3).	

M015 Torque Limit Reference before Ramps (%)

M015	Range	± 500	± 500 % <u>Note:</u> The actual range depends on the torque limit values set for the selected motor. C047–C048 Motor 1 C090–C091 Motor 2 C133–C134 Motor 3
	Active	Active for VTC and FOC controls only.	
	Address	1665	
	Function	This is the limit value for the torque at constant speed expressed as a percentage of the rated torque of the selected motor. If an external torque limit is used, the value of this measure is the torque limit obtained at constant speed; on the other hand, if the torque limit is internal to the drive, this value is the actual torque limit.	

M016 Torque Limit Reference after Ramps (%)

M016	Range	± 500	± 500 % <u>Note:</u> The actual range depends on the torque limit values set for the selected motor. C047–C048 Motor 1 C090–C091 Motor 2 C133–C134 Motor 3
	Active	Active for VTC and FOC controls only.	
	Address	1666	
	Function	This is the torque limit value being used expressed as a percentage of the motor rated torque.	

M017 Flux Reference

M017	Range	0 ÷ 500	0 ÷ 5.00 Wb
	Active	Active for VTC and FOC controls only.	
	Address	1667	
	Function	Flux reference required and expressed in Weber (Wb).	

M026 Output Current

M026	Range	0 ÷ 65535	0 ÷ 6553.5 A <u>Note:</u> The actual range depends on the drive model.
	Active	Always active.	
	Address	1676	
	Function	Measurement of the RMS of the output current.	



M026a Motor Thermal Capacity

M026a	Range	0 ÷ 1000	0.0 ÷ 100.0%
	Active	Always active.	
	Address	1728	
	Function	Heating of the connected motor. This parameter indicates the current level of the motor heating following I2t pattern set in the MOTOR THERMAL PROTECTION MENU. This value is expressed as a percentage of the allowable asymptotic value.	

M027 Output Voltage

M027	Range	0 ÷ 65535	0 ÷ 65535 V <u>Note:</u> The actual range depends on the drive voltage class.
	Active	Always active.	
	Address	1677	
	Function	Measure of the RMS of the output voltage.	

M027a Power Factor

M027a	Range	0 ÷ 1000	0.000 ÷ 1.000
	Active	Always active.	
	Address	1742	
	Function	This is the estimated value of the power factor (cosphi), such as the ratio between the active power and the apparent power at the drive output.	

M028 Output Power

M028	Range	-32768 ÷ +32767	-3276.8 ÷ +3276.7 kW <u>Note:</u> The actual range depends on the drive model.
	Active	Always active.	
	Address	1678	
	Function	Measure of the active power produced by the drive. A negative value indicates input power (the motor is regenerating energy).	

M028a Energy Consumption

M028a	Range	0 ÷ 1000000000	0 ÷ 10000000.00 kWh
	Active	Always active.	
	Address	1723-1724 (LSWord, MSWord)	
	Function	Counter of the drive energy consumption. This is a value expressed in 32 bits divided into two 16-bit words: the low part and the high part.	

M029 DC-Bus Voltage

M029	Range	0 ÷ 1400	0 ÷ 1400 V
	Active	Always active.	
	Address	1679	
	Function	Measure of the voltage in the drive DC-link.	

M030 Supply Voltage

M030	Range	0 ÷ 1000	0 ÷ 1000 V
	Active	Always active.	



	Address	1680
	Function	Measure of the RMS value of the drive supply voltage.

M004u Custom motor speed

M004u-5u	Range	± 32000 (integer part) ± 99 (decimal part)	± 32000.99 with the unit of measure defined by P268s
	Active	Always active. Decimal part active for FOC control only.	
	Address	1743 (integer part) 1744 (decimal part)	
	Function	This indicates the motor speed expressed in the unit of measure defined in P268s and scaled with the factor of scaling P268t , with respect to the motor speed M004 expressed in rpm. Example: If P268s = SPM and P268u = 0.6%, when M004 = 1000 rpm, M004u = 6 SPM.	

M009u Custom torque output

M009u	Range	± 32000	± 32000 with the unit of measure defined by P268u
	Active	Active for VTC and FOC controls only.	
	Address	1745	
	Function	It is the estimated torque generated by the motor, expressed in the unit of measure defined in P268u and scaled with the factor of scaling P268v , with respect to the torque of motor M009 expressed in Nm. Example: If P268u = ftLb and P268v = 73.75%, when M009 = 100 Nm, M009u = 73.75 ftLb.	

8.3. PID Regulator Menu

This menu contains the measures relating to the input and output values of the internal PID regulator.

M018 PID Reference at Constant RPM (%)

M018	Range	±10000	±100.00 % <i>Note:</i> The actual range depends on the max. value and the min. value of the PID reference set in parameters P245–P246 .
	Active	Always active.	
	Address	1668	
	Function	This is the measure of the PID reference expressed as a percentage. Scaling is detailed in the PID PARAMETERS MENU and the PID CONFIGURATION MENU.	

M018a PID2 Reference at Constant RPM (%)

M018a	Range	±10000	±100.00 % <i>Note:</i> The actual range depends on the max. value and the min. value of the PID2 reference set in parameters P445-P446 .
	Active	This measure is active if enabled from C291a	
	Address	1731	
	Function	This is the measure percent of the reference selected with C286 for the PID2 or the 2-zone mode. Scaling is detailed in the PID2 PARAMETERS MENU and the PID CONFIGURATION MENU.	

M019 PID Reference after Ramps (%)

M019	Range	±10000	±100.00 % <i>Note:</i> The actual range depends on the max. value and the min. value of the PID reference set in parameters P245–P246 .
	Active	Always active.	
	Address	1669	
	Function	This is the measure of the PID reference after the ramps expressed as a percentage. Scaling is detailed in the PID PARAMETERS MENU and the PID CONFIGURATION MENU.	

M019a PID2 Reference after Ramps (%)

M019a	Range	±10000	±100.00 % <i>Note:</i> The actual range depends on the max. value and the min. value of the PID2 reference set in parameters P445-P446 .
	Active	This measure is active if enabled from C291a	
	Address	1732	
	Function	This is the measure percent of the current PID reference after the ramps selected with C286 for the PID2 or the 2-zone mode. Scaling is detailed in the PID2 PARAMETERS MENU and the PID CONFIGURATION MENU.	

M020 PID Feedback (%)

M020	Range	±10000	±100.00 % <i>Note:</i> The actual range depends on the max. value and the min. value of the PID feedback set in parameters P247–P248 .
	Active	Always active.	
	Address	1670	

Function	This is the measure of the PID feedback expressed as a percentage. Scaling is detailed in the PID PARAMETERS MENU and the PID CONFIGURATION MENU..
-----------------	--

M020a PID2 Feedback (%)

M020a	Range	±10000	±100.00 % Note: The actual range depends on the max. value and the min. value of the PID2 feedback set in parameters P447-P448 .
	Active Address	This measure is active if enabled from C291a 1733	
	Function	This is the measure percent of the PID2 feedback selected with C286 for the PID2 or the 2-zone mode. Scaling is detailed in the PID2 PARAMETERS MENU and the PID CONFIGURATION MENU.	

M021 PID Error (%)

M021	Range	±10000	±100.00 % Note: The actual range depends on the min. and max. saturation values of the reference and the feedback set in parameters P245-P246 for the reference and in P247-P248 for the feedback.
	Active Address	Always active. 1671	
	Function	This is the measure of the PID input error expressed as a percentage. See also the PID PARAMETERS MENU and the PID CONFIGURATION MENU.	

M021a PID2 Error (%)

M021a	Range	±10000	±100.00 % Note: The actual range depends on the min. and max. saturation values of the reference and the feedback set in parameters P445-P446 for the reference and in P447-P448 for the feedback.
	Active Address	This measure is active if enabled from C291a 1736	
	Function	This is the measure percent of the PID2 input error or the 2-zone mode input error (difference between the reference selected with C286 and the feedback selected with C289). Please refer to the PID2 PARAMETERS MENU and the PID CONFIGURATION MENU.	

M022 PID Output (%)

M022	Range	±10000	±100.00 % Note: The actual range depends on the min. and max. saturation values of the PID output set in parameters P236-P237 .
	Active Address	Always active. 1672	
	Function	This is the measure of the output produced by the PID regulator and expressed as a percentage. Please refer to the PID PARAMETERS MENU and the PID CONFIGURATION MENU for the scaling of the PID output.	

M022a PID2 Output (%)

M022a	Range	±10000	±100.00 % Note: The actual range depends on the min. and max. saturation values of the PID output set in parameters P436-P437 .
	Active Address	This measure is active if enabled from C291a 1718	



	Function	This is the measure of the output produced by the PID2 regulator and expressed as a percentage. Scaling is detailed in the PID2 PARAMETERS MENU and the PID CONFIGURATION MENU.
--	-----------------	---

M023 PID Reference after Ramps

M023	Range	±32000	Note: The actual range depends on the max. value and the min. value of the PID reference set in parameters P245–P246 and on the gain level set in P257 .
	Active	Always active.	
	Address	1673	
	Function	This is the measure of the reference after the ramps being used for the PID regulator, as M019 but multiplied by the gain level set in P257 (see also the PID PARAMETERS MENU and the PID CONFIGURATION MENU). As for the display/keypad, the unit of measure can be programmed with parameters P267 , P267a in the DISPLAY/KEYPAD menu.	

M023a PID2 Reference after Ramps

M023a	Range	±32000	Note: The actual range depends on the min. and max. values of the PID2 reference set in parameters P445–P446 and on the gain level set in P457 .
	Active	This measure is active if enabled from C291a	
	Address	1737	
	Function	This is the measure of the reference being used for the PID2 or the 2-zone mode, as M019a but multiplied by the gain level set in P457 (see also the PID2 PARAMETERS MENU and the PID CONFIGURATION MENU). As for the display/keypad, the unit of measure can be programmed with parameters P267b , P267c in the DISPLAY/KEYPAD menu.	

M024 PID Feedback

M024	Range	±32000	Note: The actual range depends on the max. value and the min. value of the PID feedback set in parameters P247–P248 and on the gain level set in P257 .
	Active	Always active.	
	Address	1674	
	Function	This is the measure of the feedback being used for the PID regulator, as M020 but multiplied by the gain level set in P257 (see also the PID PARAMETERS MENU and the PID CONFIGURATION MENU). As for the display/keypad, the unit of measure can be programmed with parameters P267 , P267a in the DISPLAY/KEYPAD menu.	

M024a PID2 Feedback

M024a	Range	±32000	Note: The actual range depends on the max. value and the min. value of the PID2 feedback set in parameters P447–P448 and on the gain level set in P457 .
	Active	This measure is active if enabled from C291a	
	Address	1738	
	Function	This is the measure of the feedback being used for the PID2 regulator or the 2-zone mode as M020a but multiplied by the gain level set in P457 (see also the PID2 PARAMETERS MENU and the PID CONFIGURATION MENU). As for the display/keypad, the unit of measure can be programmed with parameters P267b , P267c in the DISPLAY/KEYPAD menu.	

8.4. Digital Inputs Menu

This menu allows checking the state of the command sources for the digital inputs (local terminals, serial link and fieldbus), the terminal board resulting from their combination and the terminals which are actually used for the drive control. The terminals which are actually used to control the drive also consider any timers applied to the digital inputs.

M031 Delayed Digital Inputs

M031	Range	Bit-controlled measure	See Table 1
	Active	Always active.	
	Address	1681	
	Function	Status of the control terminal board used by the drive. This is the terminal board resulting from the combination of the preset command sources (local terminal board, serial link and fieldbus), where: - Inputs MDI1 to MDI8 are the result of the OR between the different command sources. - The ENABLE (E) status is the result of the AND of inputs MDI2&S of the physical terminals and of MDI2 inputs of all the other programmed command sources. - The ENABLE SW (ESW) is the result of the AND of the inputs programmed as ENABLE SW (C152) of all the programmed command sources. See also the CONTROL METHOD MENU and the TIMERS MENU. Refer to Figure 54 for the ENABLE and ENABLE SW status.	

M032 Instant Digital Inputs

M032	Range	Bit-controlled measure	See Table 1
	Active	Always active.	
	Address	1682	
	Function	Status of the virtual control terminal board upstream of the application of the timers to the digital inputs (if no timer is applied, it matches with M031). See the CONTROL METHOD MENU and the TIMERS MENU. Refer to Figure 53 for the ENABLE and ENABLE SW status.	

Table 1: Coding of Measures M031, M032

Bit n.	Digital Input	Bit n.	Digital Input
0	MDI1	5	MDI6/ECHA/FINA
1	MDI2(ENABLE)	6	MDI7/ECHB
2	MDI3(RESET)	7	MDI8/FINB
3	MDI4	8	ENABLE-SW
4	MDI5	9	ENABLE

M033 Local Control Terminal Board

M033	Range	Bit-controlled measure	See Table 3
	Active	Always active.	
	Address	1683	
	Function	Status of the digital inputs in the drive physical terminal board. The status of MDI2&S (S) input is the result of a logic AND between ENABLE-A and ENABLE-B physical signals.	

Table 2: Coding of Measure M033

Bit n.	Digital Input	Bit n.	Digital Input
0	MDI1(START)	4	MDI5
1	MDI2&S (S)	5	MDI6/ECHA/FINA
2	MDI3(RESET)	6	MDI7/ECHB



3	MDI4	7	MDI8/FINB
---	------	---	-----------

M034 Control Terminals from Serial Link

M034	Range	Bit-controlled measure	See Table 3
	Active	Always active.	
	Address	1684	
	Function	Status of the digital inputs in the terminal board controlled via serial link.	

M035 Control Terminal Board from Fieldbus

M035	Range	Bit-controlled measure	See Table 3
	Active	Always active.	
	Address	1685	
	Function	State of the digital inputs in the terminal board controlled via fieldbus.	

Table 3: Coding of Measures M034, M035

Bit n.	Digital Input	Bit n.	Digital Input
0	MDI1	4	MDI5
1	MDI2	5	MDI6/ECHA/FINA
2	MDI3(RESET)	6	MDI7/ECHB
3	MDI4	7	MDI8/FINB

M036 Auxiliary Digital Inputs in the Terminal Board

M036	Range	Bit-controlled measure	See Table 4
	Active	Always active.	
	Address	1686	
	Function	Status of the auxiliary digital inputs in ES847 or ES870 terminal board.	

M036a Auxiliary Digital Inputs via Serial Link

M036a	Range	Bit-controlled measure	See Table 4
	Active	Always active.	
	Address	1713	
	Function	Status of the auxiliary digital inputs via serial link.	

M036b Auxiliary Digital Inputs via Fieldbus

M036b	Range	Bit-controlled measure	See Table 4
	Active	Always active.	
	Address	1717	
	Function	Status of the auxiliary digital inputs via Fieldbus.	

Table 4: Coding of Measures M036, M036a, M036b

Bit n.	Digital Input	Bit n.	Digital Input
0	XMDI1	4	XMDI5
1	XMDI2	5	XMDI6
2	XMDI3	6	XMDI7
3	XMDI4	7	XMDI8

8.5. References Menu

This menu contains the measures of the possible reference sources for speed, torque or PID available in the terminal board (analog inputs, frequency inputs and encoder input) and sent via serial link or fieldbus.

M037 REF External Analog Reference

M037	Range	Function of the preset type of reference (voltage/current).	Function of the type of reference (voltage/current) set in P050 . The numerical value always includes two decimal figures; the unit of measure is V or mA.
	Active	Always active.	
	Address	1687	
	Function	Measure of the voltage /current value detected by the drive in REF analog input.	

M038 AIN1 External Analog Reference

M038	Range	Function of the preset type of reference (voltage/current)	Function of the type of reference (voltage/current) set in P055 . The numerical value always includes two decimal figures; the unit of measure is V or mA.
	Active	Always active.	
	Address	1688	
	Function	Measure of the voltage /current value detected by the drive in AIN1 analog input.	

M039 AIN2 External Analog Reference

M039	Range	Function of the preset type of reference (voltage/current).	Function of the type of reference (voltage/current) set in P060 . The numerical value always includes two decimals; the unit of measure is V or mA.
	Active	Always active.	
	Address	1689	
	Function	Measure of the voltage /current value detected by the drive in AIN2 analog input.	

M039a XAIN4 External Analog Reference

M039a	Range	Function of the preset type of reference.	Function of the type of reference (voltage) set in P390 . The numerical value always includes two decimals; the unit of measure is V.
	Active	Active only if set via parameter R023 .	
	Address	1729	
	Function	Measure of the voltage value detected by the drive in XAIN4 analog input.	

M039b XAIN5 External Analog Reference

M039b	Range	Function of the preset type of reference.	Function of the type of reference (current) set in P395 . The numerical value always includes two decimals; the unit of measure is mA.
	Active	Active only if set via parameter R023 .	
	Address	1730	
	Function	Measure of the current value detected by the drive in the XAIN5 analog input.	

M040 Speed Reference from Serial Link

M040	Range	± 32000 (integer part) ± 99 (decimal part)	± 32000.99 rpm <u>Note:</u> The actual range depends on the selected motor, because it is defined by the value set in the parameters for the max. speed and min. speed of the selected motor. C028–C029 Motor 1 C072–C073 Motor 2 C114–C115 Motor 3
	Active	Always active.	
	Address	1690 (integer part), 1691 (decimal part)	
	Function	This is the value of the speed reference set via serial link.	

M042 Speed Reference from Fieldbus

M042	Range	± 32000 (integer part) ± 99 (decimal part)	± 32000.99 rpm <u>Note:</u> The actual range depends on the selected motor, because it is defined by the value set in the parameters for the max. speed and min. speed of the selected motor. C028–C029 Motor 1 C072–C073 Motor 2 C114–C115 Motor 3
	Active	Always active.	
	Address	1692 (integer part), 1693 (decimal part)	
	Function	This is the measure of the speed reference set by the fieldbus.	

M044 Torque Reference from Serial Link

M044	Range	± 5000	± 500.0 % <u>Note:</u> The actual range depends on the torque limit value set for the selected motor. C047–C048 Motor 1 C090–C091 Motor 2 C133–C134 Motor 3
	Active	Always active.	
	Address	1694	
	Function	This is the measure of the torque reference set via serial link and expressed as a percentage of the rated torque of the selected motor.	

M045 Torque Reference from Fieldbus

M045	Range	± 5000	± 500.0 % <u>Note:</u> The actual range depends on the torque limit values set for the selected motor. C047–C048 Motor 1 C090–C091 Motor 2 C133–C134 Motor 3
	Active Address	Always active. 1695	
	Function	This is the measure of the torque reference set by the fieldbus and expressed as a percentage of the rated torque of the selected motor.	

M046 PID Reference from Serial Link

M046	Range	±10000	±100.00 % <u>Note:</u> The actual range depends on the min. value and the max. value of the PID reference set in parameters: P245–P246
	Active Address	Always active. 1696	
	Function	This is the measure of the PID reference set via serial link and expressed as a percentage.	

M047 PID Reference from Fieldbus

M047	Range	±10000	±100.00 % <u>Note:</u> The actual range depends on the min. value and the max. value of the PID reference set in parameters: P245–P246
	Active Address	Always active. 1697	
	Function	This is the measure of the PID reference set by the fieldbus and expressed as a percentage.	

M048 PID Feedback from Serial Link

M048	Range	±10000	±100.00 % <u>Note:</u> The actual range depends on the min. value and the max. value of the PID feedback set in parameters: P247–P248
	Active Address	Always active. 1698	
	Function	This is the measure of the PID feedback set via serial link and expressed as a percentage.	

M049 PID Feedback from Fieldbus

M049	Range	±10000	±100.00 % <u>Note:</u> The actual range depends on the min. value and the max. value of the PID feedback set in parameters: P247–P248
	Active	Always active.	
	Address	1699	
	Function	This is the measure of the PID feedback set by the fieldbus and expressed as a percentage.	

M050 Encoder Reference

M050	Range	± 32000	± 32000 rpm.
	Active	Always active.	
	Address	1700	
	Function	Reading of the encoder set as a reference source (see the ENCODER/FREQUENCY INPUTS MENU and the CONTROL METHOD MENU).	

M051 Frequency Input Reference

M051	Range	1000 ÷ 10000	10000 ÷ 100000 Hz. <u>Note:</u> The actual range depends on the frequency min. value and max. value set in P071-P072 .
	Active	This measure is active only if C189 = 9/10/11/12/13 (frequency input FINA or FINB are selected).	
	Address	1701	
	Function	Frequency readout in the digital input set as a reference source (see the ENCODER/FREQUENCY INPUTS MENU and the CONTROL METHOD MENU).	

M051a RMS Input from AIN1 and AIN2

M051a	Range	0 ÷ 32000	0.00 ÷ 32.00 V
	Active	This measure is active only if one of parameters among C288 , C289 or C290 = 13: Vout measured. Also, P055 , P060 = 0: ±10V.	
	Address	3374	
	Function	RMS voltage obtained from instantaneous values of AIN1 and AIN2 if they are two sinusoidal voltage values having equal amplitude and frequency phase displacement of 120°.	

8.6. Outputs Menu

This menu allows checking the status of the digital outputs, the analog outputs and the frequency outputs located in the terminal board.

M056 Digital Outputs

M056	Range	Bit-controlled measure.	See Table 5
	Active	Always active.	
	Address	1706	
	Function	Status of digital outputs MDO1÷4 and status of the precharge contactor.	

Table 5: Coding of Measure M056

Bit n.	Digital Output
0	MDO1/FOUT
1	MDO2
2	MDO3
3	MDO4
6	Status of the precharge contactor

M056a Virtual Digital Outputs

M056a	Range	Bit-controlled measure.	See Table 6
	Active	Always active.	
	Address	1675	
	Function	Status of virtual digital outputs MPL1÷4.	

Table 6: Coding of Measure M056a

Bit n.	Digital Output
0	MPL1
1	MPL2
2	MPL3
3	MPL4

M056b Timed Flags

M056b	Range	Bit-controlled measure	See Table 7
	Active	Always active.	
	Address	1741	
	Function	Status of timed flags TFL1 ÷ 4.	

Table 7: Coding of Measure M056b

Bit n.	Timed Flag
0	TFL1
1	TFL2
2	TFL3
3	TFL4

M057 Frequency Output

M057	Range	10000÷100000	10000 ÷ 100000 Hz Note: The actual range depends on the min. value and the max. value of MDO1 digital output set as a frequency reference. Values are set in P204 and P205 (see ANALOG AND FREQUENCY OUTPUTS MENU).
	Active	Always active.	
	Address	1707	
	Function	This is the frequency measure produced by MDO1 digital output when set as a frequency output.	

M058 AO1 Analog Output

M058	Range	±100	±100 %
	Active	Always active.	
	Address	1708	
	Function	Value percent of analog output AO1, referred to the preset max. output value (maximum absolute value between P182 and P183 , see ANALOG AND FREQUENCY OUTPUTS MENU).	

M059 AO2 Analog Output

M059	Range	±100	±100 %
	Active	Always active.	
	Address	1709	
	Function	Value percent of AO2 analog output referred to the preset max. output value (maximum absolute value between P190 and P191 , see ANALOG AND FREQUENCY OUTPUTS MENU).	

M060 Analog Output AO3

M060	Range	±100	±100 %
	Active	Always active.	
	Address	1710	
	Function	Value percent of AO3 analog output referred to the preset max. output value (maximum absolute value between P198 and P199 , see ANALOG AND FREQUENCY OUTPUTS MENU).	

M061 Auxiliary Digital Outputs

M061	Range	Bit-controlled measure.	See Table 8
	Active	Always active.	
	Address	1711	
	Function	Status of the auxiliary digital outputs located on the expansion board.	

Table 8: Coding of Measure M061

Bit n.	Digital Output	Bit n.	Digital Output
0	XMDO1	3	XMDO4
1	XMDO2	4	XMDO5
2	XMDO3	5	XMDO6

8.7. Temperature Measures from PT100 Menu

This menu displays the temperatures detected in the first four analog channels of the expansion board. Scaling complies with DIN EN 60751 for PT100: 100 ohm @ 0 °C and 0.385 ohm/°C.

ES847 Expansion Board must be fitted on the equipment.
See also the EXPANSION BOARD CONFIGURATION MENU

M069 PT100 Measure in Channel 1

M069	Range	-500 ÷2600	-50.0 ÷260.0 °C
	Active	This measure is active only if programmed from parameter R023 .	
	Address	1719	
	Function	Temperature detected in analog channel 1.	

M070 PT100 Measure in Channel 2

M070	Range	-500 ÷2600	-50.0 ÷260.0 °C
	Active	This measure is active only if programmed from parameter R023 .	
	Address	1720	
	Function	Temperature detected in analog channel 2.	

M071 PT100 Measure in Channel 3

M071	Range	-500 ÷2600	-50.0 ÷260.0 °C
	Active	This measure is active only if programmed from parameter R023 .	
	Address	1721	
	Function	Temperature detected in analog channel 3.	

M072 PT100 Measure in Channel 4

M072	Range	-500 ÷2600	-50.0 ÷260.0 °C
	Active	This measure is active only if programmed from parameter R023 .	
	Address	1722	
	Function	Temperature detected in analog channel 4.	

8.8. Autodiagnosics Menu

This menu allows the user to check the functioning times and the relevant counters (for maintenance purposes) of the Penta drive; it also allows reading out the analog channels used for temperature sensors and the relevant temperature values, as well as the drive status.

M052 / M054 Functioning Times

M052 / M054	Range	0 ÷ 2147483647 (0 ÷ 7FFFFFFh)	0 ÷ 429496729.4 sec
	Address	Supply Time: 1702-1703 (LSWord, MSWord) Operation Time: 1704-1705 (LSWord, MSWord)	
	Function	This screen displays the ST (supply time) and the OT (operation time). The Operation Time is the activation time of the drive IGBTs. Both values are expressed in 32 bits divided into two 16-bit words: the low part and the high part.	

Functioning Times:

S	u	p	p	l	y	T	i	m	e			
M	0	5	4	=	5	3	:	2	5	:	0	1
O	p	e	r	a	t	i	o	n	T	i	m	e
M	0	5	2	=	2	9	:	3	5	:	5	1

M062 Ambient temperature Measure

M062	Range	± 32000	± 320.0 °C
	Active	Always active.	
	Address	1712	
	Function	Ambient temperature measured on the surface of the control board.	

M064 IGBT Heatsink Temperature Measure

M064	Range	± 32000	± 320.0 °C
	Active	Always active.	
	Address	1714	
	Function	Measure of the IGBT heatsink temperature. If the temperature readout is <-30.0 °C or >150.0 °C, warning W50 NTC Fault appears. <u>Note:</u> Not all models are provided with the NTC sensor (see Table 17 in the PRODUCT MENU). If this sensor is not provided, the measure is forced to 32,000, corresponding to +320.0 °C.	

M065 Operation Time Counter

M065	Range	0÷65000	0÷650000h
	Active	Always active.	
	Address	1715	
	Function	Time elapsed after resetting the operation time counter. The Operation Time is the activation time of the drive IGBTs.	

M066 Supply Time Counter

M066	Range	0÷65000	0÷650000h
	Active	Always active.	
	Address	1716	
	Function	Time elapsed after resetting the supply time counter.	

M089 Drive Status

M089	Range	See Table 139	
	Active	Always active.	
	Address	1739	
	Function	Describes the current condition of the Penta drive.	

M090 Active Alarm

M090	Range	See Table 136	
	Active	Always active.	
	Address	1740	
	Function	Alarm tripped at the moment.	

8.9. Data Logger Measures Menu

This menu displays the status of the types of connections (serial links, Ethernet and modem) supported by ES851 Data Logger board.

This menu can be viewed only if the Data Logger board is fitted.
See also the DATA LOGGER MENU.

M100 Data Logger Status (Line 3)

M100 Line 3	Range	0 ÷ 2	0: NOT FITTED 1: OK not interlocked 2: OK interlocked
	Active	This measure is active only if programmed from parameter R021 .	
	Address	1336	
	Function	<p>0: NOT FITTED, ES851 is not installed on the Penta drive.</p> <p>1: OK not interlocked, ES851 is operating independently of the drive where it is installed. To program ES851, a connection to a computer via the RemoteDrive software is required, or a special preset set via display/keypad is required (see the DATA LOGGER MENU).</p> <p>2: OK interlocked, ES851 is ready to be configured even through the display/keypad of the drive where it is installed.</p>	

M100 ES851 Fault (Line 4)

M100 Line 4	Range	0 ÷ 6, 99 ÷ 104	0: No alarm 1: Parameter save fault 2: Log write error 3: FBS configuration failure 4: RS232 Modbus configuration failure 5: RS485 Modbus configuration failure 6: TCP/IP stack configuration failure 99: Flash card lacking or inaccessible 100: Invalid stream access 101: TCP/IP socket fault 102: Dial out connection failure 103: Control board clock failure 104: Modem initialization failure
	Active	This measure is active only if programmed from parameter R021 .	
	Address	1340	
	Function	This indicates a general alarm tripped for ES851. In case an alarm trips, please contact BRAMMER's CUSTOMER SERVICE and mention the alarm code and name.	

M101 Connection Status

M101	Range	Bit-controlled measure	See Table 9
	Active Address	This measure is active only if programmed from parameter R021 .	
	Function	1338 Status of the connections supported by ES851. Note that the COM1 serial link is RS232 by default, whereas COM 2 is RS485 by default. For more details, please refer to the Programming Guide manual for the Data Logger ES851.	

Table 9: Data Logger connection status

Bit n.	Connection	Description
0-7	Type of modem connection failure	0: None 1: Dial KO 2: Connect KO 3: Authentication KO 4: IPCP KO* 5: Modem not yet initialized 6: Modem init KO 7: Modem not configured 8: Modem not dial out 16: Connect end (echo time out) 32: Connect end (idle time out) 64: Connect end (term expired)
8-10	Status of the connection via modem	0: No conn. 1: Dialing 2: Connecting 4: Connected 5: Attempt finished
11	COM1	0: No data exchange 1: Data exchanged
12	COM2	0: No data exchange 1: Data exchanged
13	Ethernet	0: No connection 1: Connection
14-15	Reserved	

* In computer networking, the **Internet Protocol Control Protocol (IPCP)** is a network control protocol for establishing and configuring Internet Protocol over a Point-to-Point Protocol link. The IPCP configures, enables, and disables the IP protocol modules on both ends of the point-to-point link.

8.10. Encoder Measures Menu

The Encoder Measures Menu displays the measures of the incremental and absolute position sensors (if any), as well as some useful info for managing those sensors.

M120 Encoder A Count Value

M120	Range	0 ÷ 65535	0 ÷ 65535 <u>Note:</u> The actual range of this measure is based on the type of encoder being used.
	Active	Always active	
	Address	1746	
	Function	This is the count value of encoder A (see ENCODER/FREQUENCY INPUTS MENU). When the inverter is powered on, the initial value is always 0.	

M121 Encoder B Count Value

M121	Range	0 ÷ 65535	0 ÷ 65535 <u>Note:</u> The actual range of this measure is based on the type of encoder being used.
	Active	Always active	
	Address	1747	
	Function	This is the count value of encoder B (see ENCODER/FREQUENCY INPUTS MENU). When the inverter is powered on, the initial value is always 0.	

M122 Absolute Encoder Count Value

M122	Range	0 ÷ 65535	0 ÷ 65535 <u>Note:</u> The actual range of this measure is based on the type of encoder being used.
	Active	Always active	
	Address	3243	
	Function	This is the count value of the absolute encoder (or encoder M) (see ENCODER/FREQUENCY INPUTS MENU). When the inverter is powered on, the initial value is always 0.	

8.11. Digital Input Settings Menu

This menu allows checking the functions assigned to the digital inputs.

Table 10: Coding of the functions assigned to the digital inputs

Displayed Items	Function Assigned to the Digital Inputs
STOP	Stop function
REVERSE	Startup with negative speed
EN-SW	ENABLE SW
DISABLE	Drive disable
Mspd0	Multispeed 0
Mspd1	Multispeed 1
Mspd2	Multispeed 2
Mspd3	Multispeed 3
CW/CCW	Reversal of the direction of rotation
DCB	DC braking
UP	Reference increase
DOWN	Reference decrease
UDReset	Reset of speed setpoint due to UP/DOWN command
Alarm 1	Auxiliary trip 1
Alarm 2	Auxiliary trip 2
Alarm 3	Auxiliary trip 3
MRmp0	Multiramp 0
MRmp1	Multiramp 1
JOG	Jog mode
SLAVE	Selection of Slave Mode
PID Dis	PID Disable
KpdLock	Display/keypad unit
Mot 2	Selection of Motor 2
Mot 3	Selection of Motor 3
Var 0	Reference Variation 0
Var 1	Reference Variation 1
Var 2	Reference Variation 2
PID UDR	PID Reference Reset due to UP/DOWN commands
LOCAL	Selection of Local mode
Brk Lock	Mechanical brake locking
FireM	Fire Mode enabled
Src. Sel	Reference/command source switch
nTlim	External torque limit disable
START_B	START function, terminals B
STOP_B	STOP function, terminals B
REVERSE_B	Startup with negative speed, terminals B
MRef0	PID Multireference 1
MRef1	PID Multireference 2
MRef2	PID Multireference 3
PID Csl	PID Control Selection
START	START function
ENABLE	ENABLE function
RESET	Alarm RESET
EncA	Encoder A Input
EncB	Encoder B Input
FinA	FINA Frequency input
FinB	FINB Frequency input
Multi	More than one function allocated to the same input

8.12. Fault List Menu

Scroll the **Fault List Menu** to display the codes of the last eight alarms tripped.

Press the **SAVE/ENTER** key to access the alarm submenu and navigate to each value measured by the drive when the alarm tripped.

The diagram below shows a navigation example for the **Fault List Menu** (relating to alarm n.1 in particular). Note that n.1 is the last alarm tripped and n.8 is the first alarm tripped.

The measures marked with **Mxxx** are the same measures covered in this section.

If the Data Logger ES851 is installed (even the ES851 RTC version only) and parameter **R021** Data Logger is set to 2: ENABLE, the date and time when the alarm has tripped are displayed instead of the Supply Time (ST) and the Operation Time (OT) respectively.

Navigation Example - Fault List Menu.

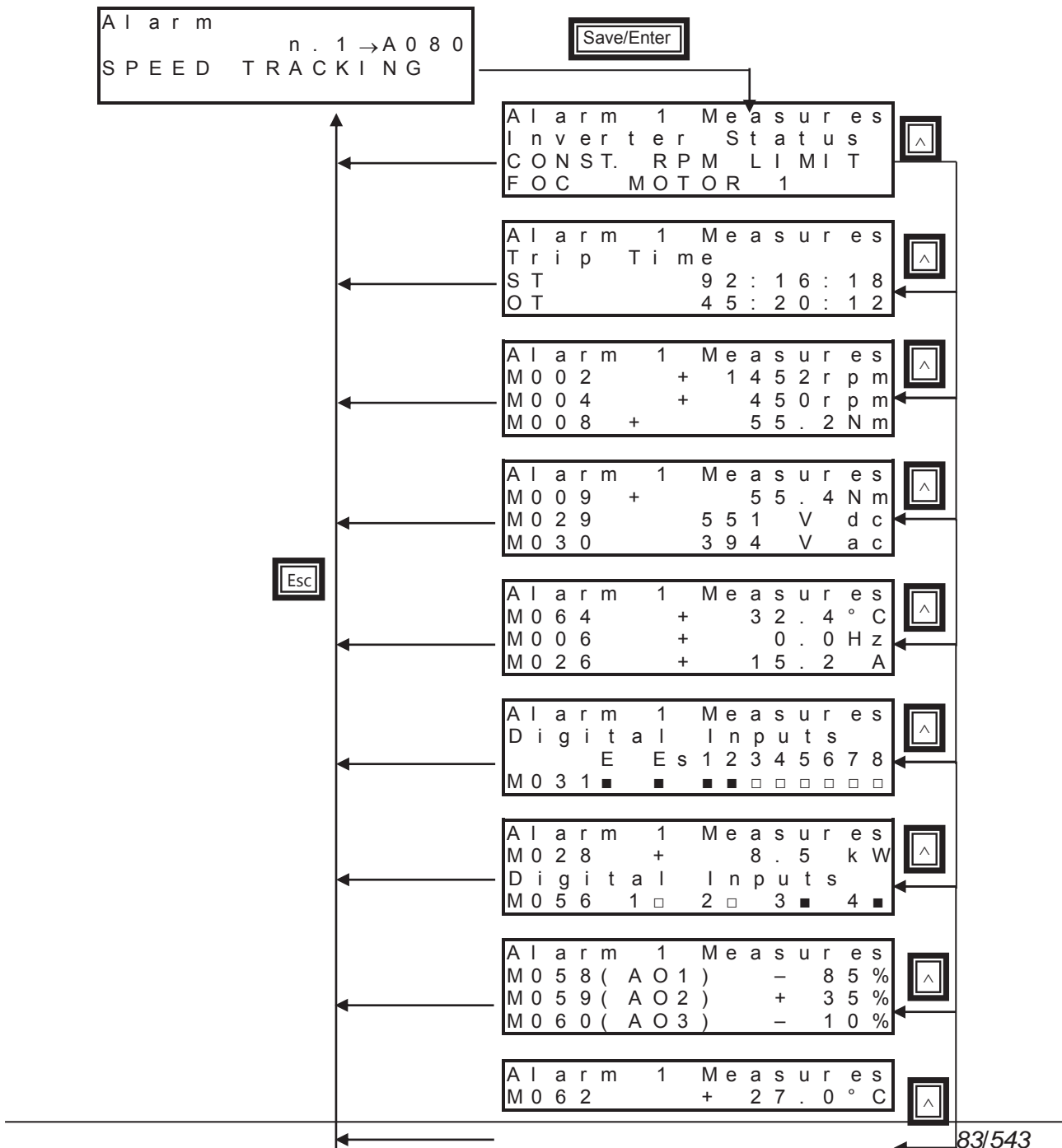



Table 11: Modbus base addresses in the Fault Lists

Fault List	Modbus Base Address
FL1	7712
FL2	7744
FL3	7776
FL4	7808
FL5	7840
FL6	7872
FL7	7904
FL8	7936

Table 12: List of the measures in the Fault Lists

Measure	Function	Range	Value	Modbus Offset Address
M090	Active Alarm	See Table 136	-	0
M052	Supply Time	See measure description	-	1: LSW 2: MSW
M054	Operation Time	See measure description	-	3: LSW 4: MSW
M089	Inverter Status	See Table 139	-	5
M026	Output Current	0 ÷ 65535	0 ÷ 6553.5 A	6
M004	Motor Speed	±32000	±32000 rpm	7
M002	Speed Reference after Ramps	±32000	±32000 rpm	8
M008	Torque Demand	±32000	±32000 Nm	9
M009	Torque Generated by the Motor	±32000	±32000 Nm	10
M029	DC-bus Voltage	0 ÷ 1400	0 ÷ 1400 V	11
M030	Grid Voltage	0 ÷ 1000	0 ÷ 1000 V	12
M064	IGBT Heatsink Temperature	±32000	± 320.0 °C	13
M006	Inverter Output Frequency	±10000	±1000.0 Hz	14
M031	Delayed Digital Inputs	See measure description	-	16
-	Selected Motor (high byte)	0 ÷ 2	0: Mot1 1: Mot2 2: Mot3	17
-	Selected Control (low byte)	0 ÷ 2	0: IFD 1: VTC 2: FOC	
M028	Output Power	0 ÷ 65535	0 ÷ 6553.5 kW	19
M056	Digital Outputs	See measure description		20
M058	Analog output AO1	±100	±100 %	21
M059	Analog output AO2	±100	±100 %	22
M060	Analog output AO3	±100	±100 %	23
M062	Ambient Temperature	±32000	± 320.0 °C	24

To get the Modbus address of a given measure in a Fault List, sum up the base address to the measure's offset.

Example:

The address of measure **M058** in Fault List **FL6** is as follows:

$$7872 + 21 = 7893$$

8.13. Power Off List Menu

This menu contains the measures of some characteristic variables detected at the drive power off, in conjunction with the alarm (if any) tripped at that moment.

Press the **SAVE/ENTER** key to access the submenu and navigate to the measures detected by the drive when the alarm tripped. Measures and codes are the same as the ones shown in the Fault List Menu.

If the Data Logger ES851 is installed (even the ES851 RTC version only) and parameter **R021** Data Logger is set to 2: ENABLE, the date and time when the alarm has tripped are displayed instead of the Supply Time (ST) and the Operation Time (OT) respectively.

The diagram below shows a navigation example for the **Power Off List**.

Navigation Example – PowerOff List Menu

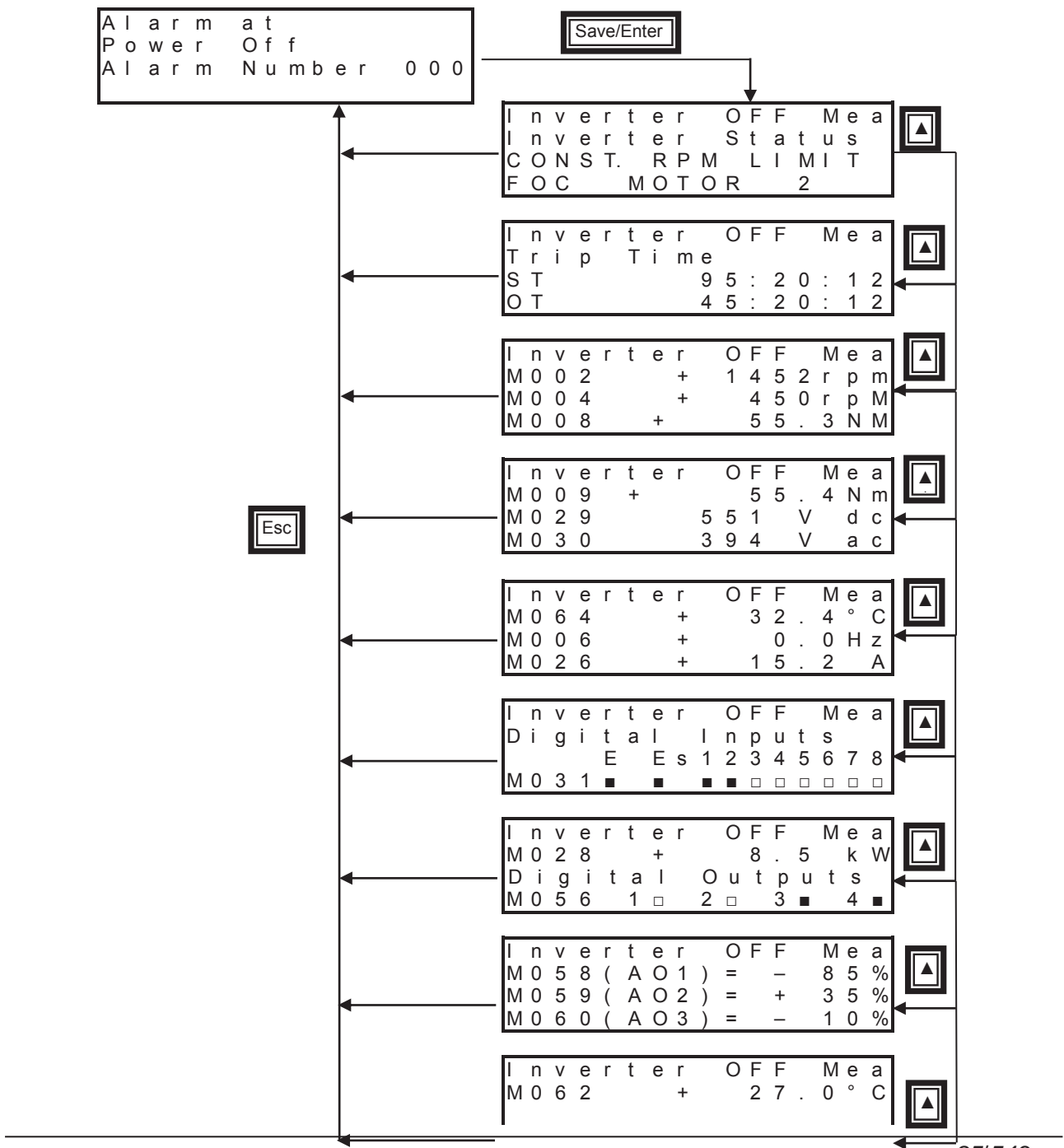

Table 13: List of the measures in the Power Off List

Measure	Function	Range	Value	Modbus Address
M090	Active Alarm	See Table 136	-	5044
M052	Supply Time	See measure description	-	5045: LSW 5046: MSW
M054	Operation Time	See measure description	-	5047: LSW 5048: MSW
M089	Inverter Status	See Table 139	-	5049
M026	Output Current	0 ÷ 65535	0 ÷ 6553.5 A	5050
M004	Motor Speed	±32000	±32000 rpm	5051
M002	Speed Reference after Ramps	±32000	±32000 rpm	5052
M008	Torque Demand	±32000	±32000 Nm	5053
M009	Torque Generated by the Motor	±32000	±32000 Nm	5054
M029	DC-bus Voltage	0 ÷ 1400	0 ÷ 1400 V	5055
M030	Grid Voltage	0 ÷ 1000	0 ÷ 1000 V	5056
M064	IGBT Heatsink Temperature	±32000	± 320.0 °C	5057
M006	Inverter Output Frequency	±10000	±1000.0 Hz	5058
M031	Delayed Digital Inputs	See measure description	-	5060
-	Selected Motor (high byte)	0 ÷ 2	0: Mot1 1: Mot2 2: Mot3	5061
-	Selected Control (low byte)	0 ÷ 2	0: IFD 1: VTC 2: FOC	
M028	Output Power	0 ÷ 65535	0 ÷ 6553.5 kW	5063
M056	Digital Outputs	See measure description		5064
M058	Analog output AO1	±100	±100 %	5065
M059	Analog output AO2	±100	±100 %	5066
M060	Analog output AO3	±100	±100 %	5067
M062	Ambient Temperature	±32000	± 320.0 °C	5068

9. PRODUCT MENU

9.1. Overview

The Product Menu includes parameter **P263 Language**, allowing the user to select a dialog language; it also contains the Fire Mode enabling Password and the following information (read-only) about the product:

Product Name and Type
Implemented Software
SW Versions
Serial Number
Manufacturer

9.2. List of Parameter P263 and Fire Mode Enable Password

Table 14: List of Parameter P263 and Fire Mode Enable Password

Parameter	FUNCTION	User Level	DEFAULT VALUE	MODBUS Address
P263	Language	BASIC	1:ENGLISH	863
	Fire Mode Enable Password	BASIC	0	868

P263 Language

P263	Range	0 ÷ 4	0: ITALIANO 1: ENGLISH 2: ESPAÑOL 3: PORTUGUES 4: DEUTSCH (F1 version – standard)	0: DANISH 1: ENGLISH 2: NORWEGIAN 3: FINNISH 4: SWEDISH (F2 version – on demand)	0: RUSSIAN 1: ENGLISH 2: ESPAÑOL 3: PORTUGUES 4: DEUTSCH (F3 version – on demand)	0: ITALIANO 1: ENGLISH 2: ESPAÑOL 3: PORTUGUES 4: FRANÇAIS (F4 version – on demand)
	Default Level	1	1: ENGLISH			
	Address	863				
	Function	The dialog language is factory set to English. Use parameter P263 to choose a different language. The software implemented in the display/keypad is called MMI (man/machine interface); its version is displayed in the SW screen of the Product Menu.				



CAUTION

The available language set is that of standard version F1. Versions F2, F3 and F4 are to be explicitly requested at the time when ordering the drive.

Product Name and Type

Product Name and Type	Range	Fan control: bits 0 to 3 Voltage class: bits 4 to 7 Drive model: bits 8 to 15	0 ÷ 7 – see Table 18 0 ÷ 3 – see Table 16 0 ÷ 96 – see Table 15
	Address	1593	
	Function	This screen displays the name of the product (PENTA) and the type of product (see example below).	

P	r	o	d	u	c	t		N	a	m	e				
P	E	N	T	A											
T	y	p	e		0	0	2	0		4	T		-	-	-

The product name (PENTA) appears in the second line of the display/keypad. The third line shows the voltage class, the model of the drive and the type of fan control.
In the case shown in the example, the voltage class is 4T (400V), the model of the drive is 0020 and the fan operation is not controlled by the drive (character _).

The numbers corresponding to the different models of the Penta Drive are given in the table below:

Table 15: Indexes corresponding to the different models of the Penta Drive

Index	Model	Index	Model	Index	Model	Index	Model	Index	Model
0	0003	20	0023	40	0076	60	0259	80	0748
1	0004	21	0024	41	0086	61	0260	81	0749
2	0005	22	0025	42	0088	62	0290	82	0750
3	0006	23	0030	43	0113	63	0312	83	---
4	0007	24	0032	44	0129	64	0313	84	0828
5	0008	25	0033	45	0131	65	0314	85	0831
6	0009	26	0034	46	0150	66	0366	86	0832
7	0010	27	0035	47	0162	67	0367	87	0850
8	0011	28	0036	48	0164	68	0368	88	0960
9	0012	29	0037	49	---	69	0399	89	0964
10	0013	30	0038	50	0179	70	0401	90	0965
11	0014	31	0040	51	0180	71	0402	91	1128
12	0015	32	0042	52	0181	72	0457	92	1129
13	0016	33	0049	53	0200	73	0459	93	1130
14	0017	34	0051	54	0201	74	0523	94	1296
15	0018	35	0060	55	0202	75	0524	95	1800
16	0019	36	0062	56	0216	76	0526	96	2076
17	0020	37	0067	57	0217	77	0598	97	---
18	0021	38	0069	58	0218	78	0599	98	---
19	0022	39	0074	59	0250	79	0600	99	---

Table 16: Voltage classes of the Penta Drive

Index	Class
0	2T
1	4T
2	5T
3	6T

The type of fan control is marked by 3 characters:

Table 17: Fan control modes

Character	Description
F	The fan activation is controlled by the inverter.
S	The fan operation is correct: when a fan fault is detected, the relevant alarm trips.
N	A NTC sensor is fitted, that acquires the heatsink temperature. The fan activation threshold is set in parameter C264 .

Table 18: Coding for fan activation

Code	Symbol	Fan control	Fan status	NTC
0	---	No	No	No
1	-S-	No	Yes	No
2	F--	Yes	No	No
3	FS-	Yes	Yes	No
4	--N	No	No	Yes
5	-SN	No	Yes	Yes
6	F-N	Yes	No	Yes
7	FSN	Yes	Yes	Yes

SW Application

SW Application	Function
	This screen displays the type of software application which is implemented in the drive (e.g. Regenerative). For the application software downloading instructions see the RemoteDrive DRIVE REMOTE CONTROL - User Manual.

SW Versions

SW Versions	Range	0 ÷ 65535	0 ÷ 65.535
	Address	Texas: 475 MMI: 1489 Motorola: 1487	
	Function	This screen displays the SW versions implemented on the Penta drive: Texas → SW version of the Texas DSP MMI → SW version of the display/keypad Motorola → SW version of Motorola microprocessor	

Maximum Output Frequency

Maximum Output Frequency	Range	0 ÷ 999	0 ÷ 999 Hz
	Address	3327	
	Function	This screen displays the maximum allowable output frequency (Hz) for the drive.	



NOTE

The maximum output frequency is factory-set to 599Hz for any drive models, even those which can withstand higher output frequency values (see Maximum Programmable Speed Value). If the factory-set output frequency is to be increased, this is to be explicitly specified when ordering the equipment.

Serial Number

Serial Number	Range	0 ÷ 9999999	0 ÷ 9999999
	Address	1827-1828 (LSWord, MSWord)	
	Function	This is the serial number of the drive. The serial number is required when contacting BRAMMER's CUSTOMER SERVICE in order to activate the Fire Mode. This measure is expressed in 32 bits divided into two 16-bit words: the low part and the high part.	

Fire Mode Enable Password

Fire Mode Enable Password	Range	0 ÷ 9999	0 ÷ 9999
	Default	0	0
	Level	BASIC	
	Address	868	
	Function	To enable the Fire Mode, please contact BRAMMER's CUSTOMER SERVICE and give the Serial Number of the drive where the Fire Mode is to be activated. Enter the password given by the Customer Service.	



CAUTION The Fire Mode Enable Password is set to 0 when the Restore Default is performed.

Manufacturer

Manufacturer	Function	The name of Brammer is displayed followed by Brammer's website (BRAMMER.NO).
---------------------	-----------------	--

You can also send a Modbus query message to read the product ID.

Product ID

Product ID	Range	1 ÷ 65535	1 ÷ 65535
	Address	476	
	Function	You can read the product ID from address 476. The eight high bits give the first character of the ID, the eight low bits give the second character of the product ID. E.g. for PD (Penta Drive): MODBUS value read from address 476: 20548d → 0x5044H 50H → Character 'P' 44H → Character 'D'	

10. PASSWORD AND USER LEVEL MENU

10.1. Overview

The Password and User Level menu allows changing the programming parameters and sets their visibility.

- **P000** enables parameter modification
- **P001** sets the user level
- **P002** allows to change the password set in **P000**
- **P003** conditions required to change C parameters

10.2. List of Parameters P000 to P003

Table 19: List of Parameters P000 to P003

Parameter	FUNCTION	User Level	DEFAULT VALUES	MODBUS Address
P000	Write enable	BASIC	00001	513
P001	Programming level	BASIC	0:[Basic]	514
P002	Write enable password	ENGINEERING	00001	510
P003	Conditions required to change C parameters	ADVANCED	StandBy+Fluxing	509

P000 Write Enable

Factory setting is **P000 = 1** (parameter write is enabled). To access parameter **P000** allowing parameter write, access the Password and User Level Menu from the Parameters Menu.

P000	Range	00000+32767	00000: [No] +32767
	Default	00001	00001
	Level	BASIC	
	Address	Cannot be accessed via serial link. Parameter write via serial link is always enabled.	
	Function	Set the correct value in P000 to enable parameter write. The default password for P000 is 00001. You can enter a custom password in P002 .	

P001 User Level

P001	Range	0÷2	0: Basic 1: Advanced 2: Engineering
	Default	0	0 : Basic
	Level	BASIC	
	Address	514	
	Function	<p>The inverter programming parameters are grouped by access levels based on their functions (more or less complex functions). Some menus, or some parts of menus, are not displayed when a given access level is selected. When the BASIC access level is selected once the inverter parameterization is correct, navigation is easier, as only frequently accessed parameters are displayed. The User Level is stated for each parameter.</p>	

P002 Password for Write Enable

P002	Range	00001 ÷ 32767	00001 ÷ 32767
	Default	00001.	
	Level	ENGINEERING	
	Address	510	
	Function	Once write is enabled after entering the correct password in P000 , you can use parameter P002 to enter a custom password.	



CAUTION The new password allowing parameter write is the value entered in **P002**. Note it down and keep it handy!

P003 Conditions for C Parameter Modifications

P003	Range	0 ÷ 1	0:[Stand-by only] ÷ 1:[StandBy+Fluxing]
	Default	1	1:[StandBy+Fluxing]
	Level	ADVANCED	
	Address	509	
	Function	<p>Factory setting allows C parameters to be programmed even when the inverter is enabled. However, the motor must be stopped. If P003=0: [Stand-by only], C parameters can be changed only when the inverter is disabled. This parameter also affects the behaviour of the digital inputs for LOC/REM and motor selection: when those inputs change, they produce their effect only when C parameters are allowed to be changed, according to the value in P003.</p>	



CAUTION If **P003 = 1:[StandBy+Fluxing]** when changing a C parameter, the drive automatically disables (stops modulating) and the motor starts idling.



NOTE If **C010 = 0: IFD [Voltage/Frequency]**, C parameters may be set up when the **ENABLE-A** and **ENABLE-B** inputs are active and the motor is stopped independently of **P003**.

11. DISPLAY/KEYPAD MENU

11.1. Overview



NOTE

It is recommended that the “Operating and Remoting the Keypad” section in the Motor Drives Accessories - User Manual be read as well.

The Display/Keypad Menu contains programming parameters to do the following:
 Set the navigation mode within the drive menus;
 Select the Root Page;
 Select measures from the Root Page and the Keypad Page;
 Select the type of Keypad Page displayed in Local mode;
 Set custom PID units of measure;
 Disable the **LOC/REM** or **FWD/REV** keys in the keypad.

The Root Page, the Keypad Page and Local mode are detailed in the following sections.

11.2. Root Page

```

I N V E R T E R   O K
→           +   1 5 0 0 . 0 0 r p m
→           +           0 . 0 0 r p m
M E A   P A R   C F [ I D P ]
    
```

The Root page is factory-set as the startup page to be displayed when the drive is turned on.



NOTE

You can access the four main menus only from the root page:

- MEA** → Measures;
- PAR** → Programming parameters;
- CF** → Configuration parameters;
- IDP** → Product identification.

Line 1 on this page displays the drive operating status (see the description of parameter **M089**).

Lines 2 and 3 display two measures which may be selected with parameters P268, P268a. These measures can be scaled through parameters P268y and P268z.

Line 4 displays the four main menus of the drive. The selected menu is displayed in square brackets: use the **▲** and **▼** keys to select a different menu. Press the **SAVE/ENTER** key to access the selected menu.

11.3. Keypad Page and Local Mode

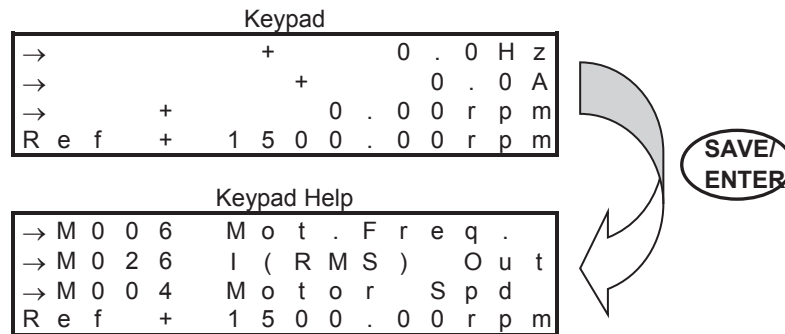

To access the Keypad pages, press the **MENU** key from the Root Page or press the **LOC/REM** key after selecting the Local mode.

The measures displayed on the Keypad page can be set up through parameters **P268b** to **P268e**. From the Keypad page, press the **SAVE/ENTER** key to display the Keypad Help page, describing the measures displayed on the Keypad page. The Keypad Help page is displayed for a few seconds.



NOTE

If parameter **P264b** (Navigation mode via **MENU** key) is set to Operator, navigation is locked once the Keypad Page is displayed. Press the **ESC** key for a few seconds to resume navigation.

The following Keypad Pages are available:

- Measures only → four lines displaying measures only
- Speed → line 4 shows the speed reference, that can be changed with the ▲ and ▼ keys.
- Torque → line 4 shows the torque reference, that can be changed with the ▲ and ▼ keys.
- Limit Torque → line 4 shows the limit torque reference, that can be changed with the ▲ and ▼ keys.
- PID → line 4 shows the PID reference, that can be changed with the ▲ and ▼ keys.

If the Local Mode is NOT selected, pressing the MENU key allows viewing only the pages containing the references sent via keypad (see the CONTROL METHOD MENU and the PID CONFIGURATION MENU).

LOCAL MODE

In **LOCAL** mode (the L-CMD and L-REF LEDs come on when the Local mode is active), only the commands and references sent via keypad are enabled, while any other command source or reference source is disabled (see the CONTROL METHOD MENU, the DIGITAL INPUTS MENU and the INPUTS FOR REFERENCES MENU). The keypad page displayed when the **LOC/REM** key is pressed depends on the setting of parameter **P266** (Type of Keypad Page in Local Mode):

P266 = Measures Only → Page containing 4 preset measures; no reference can be changed.

P266 = Ref.Activated → Line 4 in the Keypad Page enables changing the drive reference: the speed reference if a speed control is activated (“Ref” displayed), the torque reference if a torque control is activated (“TRef” displayed). If the drive reference is the PID output (**C294** PID Action = 1:[Reference]), the PID reference is given (“PRef” displayed). Use the ▲ and ▼ keys to change the reference displayed in line 4 on the Keypad Page.

P266 = Ref.Activated+Spd → To be used only when the drive reference depends on the PID output when a speed control is used (**C294** PID Action = 1:[Reference]). When the **LOC/REM** key is pressed for the first time, “PRef” is displayed in line 4 and the PID reference may be adjusted; when the **LOC/REM** key is pressed twice, the PID is disabled and the speed reference can be changed (“Ref” displayed). Use the ▲ and ▼ keys to change the reference shown in line 4 on the Keypad Page.

11.4. List of Parameters P264 to P269b

Table 20: List of Parameters P264 to P269b

Parameter	FUNCTION	User Level	DEFAULT SETTING	MODBUS Address
P264	Navigation mode	ADVANCED	0 :[BY MENU]	864
P264a	Circular navigation	ADVANCED	1: [YES]	865
P264b	Navigation mode with the MENU key	ADVANCED	0:[STANDARD]	512
P265	Root page	ADVANCED	3: [Start Up]	866
P266	Type of Keypad page in Local Mode	ADVANCED	1:[Ref.Activated]	511
P267	Preset PID units of measure	ENGINEERING	0:[Disable]	867
P267a	Custom PID units of measure	ENGINEERING	[%]	1851
P267b	Preset PID2 units of measure	ENGINEERING	0:[Disable]	861
P267c	Custom PID2 units of measure	ENGINEERING	[%]	1865
P268	Measure n.1 on Root page	ADVANCED	M004 Motor Spd	cannot be accessed
P268y	Scaling of Measure n.1 on Root page	ADVANCED	100.00%	515
P268a	Measure n.2 on Root page	ADVANCED	M000 Speed Ref.	cannot be accessed
P268z	Scaling of Measure n.2 on Root page	ADVANCED	100.00%	516
P268b	Measure n.1 on Keypad page	ADVANCED	M006 Mot.Freq.	cannot be accessed
P268c	Measure n.2 on Keypad page	ADVANCED	M026 Motor Current	cannot be accessed
P268d	Measure n.3 on Keypad page	ADVANCED	M004 Motor Spd	cannot be accessed
P268e	Measure n.4 on Keypad page	ADVANCED	M000 Speed Ref.	cannot be accessed
P268s	Custom Motor Speed unit of measure	ENGINEERING	rpm	722
P268t	Scaling of Custom Motor Speed	ENGINEERING	100.00%	517
P268u	Custom Torque unit of measure	ENGINEERING	Nm	723
P268v	Scaling of Custom Torque	ENGINEERING	100.00%	518
P269	Disable LOC/REM FWD/REV keys	ENGINEERING	[NO NO]	869
P269b	ESC key to restore previous value	ENGINEERING	[NO]	1051

P264 Navigation Mode

P264	Range	0 ÷ 2	0: By Menu 1: Changed Pars Only 2: Linear
	Default	0	0: By Menu
	Level	ADVANCED	
	Address	864	
	Function	Navigation by menu is factory-set and is activated whenever the Penta drive is powered on. Set P264=1 : [Changed Pars Only] to navigate only through the parameters whose default values have been changed. In that case, linear navigation becomes active: only the parameters that have been changed are displayed in sequence. Press the ▲ and ▼ keys to go to a different parameter. Navigation is slower if only few parameters have been changed. Set P264=2 : [Linear] to display parameters in sequence using the ▲ and ▼ keys. If Linear navigation is selected, parameters are no longer divided into menus and submenus.	



NOTE

This parameter cannot be saved. Navigation by menu is restored whenever the drive is powered on.

P264a Circular Navigation

P264a	Range	0 ÷ 1	0: [NO] 1: [YES]
	Default	1	1: [YES]
	Level	ADVANCED	
	Address	865	
	Function	<p>Parameter P264a is factory set to 1:[YES]. This means that “wrap” navigation is activated: navigation starts from the first page of the selected menu. Press ▲ to go to the next page. When the last page is displayed, press ▲ again to <u>return to the first page of the selected menu</u>.</p> <p>From the first page of the selected menu, press ▼ to go to the last page of the active menu.</p> <p>If P264a=0: [NO], when the last page of the active menu is displayed, the ▲ key is disabled; you can only view the previous pages—up to the first page of the active menu—by pressing the ▼ key.</p>	

P264b Navigation Mode with the MENU Key

P264b	Range	0 ÷ 1	0: [STANDARD] 1: [OPERATOR]
	Default	0	0: [STANDARD]
	Level	ADVANCED	
	Address	512	
	Function	<p>Press the MENU key from any parameter to go to the access page of the menu containing that parameter; press the MENU key again to go to the Root page; press the MENU key again to go to the Keypad page.</p> <p>If factory setting is active (P264b=0: [STANDARD]) press the MENU key from the Keypad page to go to the Root page, then to the starting parameter. If P264b=1: [OPERATOR], navigation is locked once the Keypad Page is displayed. Hold down the ESC key for a few seconds to resume navigation. This prevents inexperienced users from navigating through the parameters stored to the keypad. If the Keypad page is preset as the startup page (P265=1: [Measures]) and P264b=1 :[OPERATOR], navigation is always locked.</p>	

P265 Startup Page

P265	Range	0 ÷ 3	0: [Root] 1: [Measures] 2: [Keypad] 3: [Start-Up]
	Default	3	3: [Start-Up]
	Level	ADVANCED	
	Address	866	
	Function	<p>P265 sets the page to be displayed when the drive is turned on.</p> <p>P265 = 0: the Root page is the startup page.</p> <p>P265 = 1: the Keypad Page displaying 4 measures only is the startup page.</p> <p>P265 = 2: The Keypad page displaying a reference in line 4 is the startup page.</p> <p>P265 = 3: the START-UP MENU is the startup page.</p>	

P266 Type of Keypad Page in Local Mode

P266	Range	0 ÷ 2	0: [Measures Only] 1: [Ref.Activated] 2: [Ref.Activated+Speed]
	Default	1	1: [Ref.Activated]
	Level	ADVANCED	
	Address	511	
	Function	<p>P266 sets the type of keypad page to be displayed in Local mode.</p> <p>If P266 = 0: [Measures Only] in Local mode, the reference cannot be changed.</p> <p>If P266 = 1: [Ref.Activated] in Local mode, the Keypad page containing the activated reference is displayed; for example, if a torque control is active, the Keypad page displayed in Local mode shows the torque reference in line 4. Use the ▲ and ▼ keys to change the torque reference.</p> <p>If a speed control is active and the drive reference is the PID output (C294 PID Action = 1: [Reference]), when in Local mode, you should disable the PID regulator and send a speed reference from keypad (to do so, set P266 = 2: [Ref.Activated+Speed]).</p> <p>When pressing the LOC/REM key to enter the Local mode, the Keypad page containing the PID reference is displayed. Use the ▲ and ▼ keys to change the PID reference.</p> <p>Press the LOC/REM key once again (when the drive is disabled) to disable the PID control. The Keypad page containing the speed reference is displayed. Use the ▲ and ▼ keys to change the speed reference.</p>	

P267/P267b Preset PID/PID2 Units of Measure

P267/P267b	Range	0 ÷ 39	See Table 21
	Default	0	0: [Disable]
	Level	ENGINEERING	
	Address	867/861	
	Function	<p>The PID/PID2 reference and PID/PID2 feedback are expressed as a percentage in measures M019, M020, M019a, M020a.</p> <p>Parameters P257/P457 allow setting a gain value to “scale” the PID reference and PID feedback and to obtain the following measures: M023 = P257 * M019; M024 = P257 * M020; M023a = P457 * M019a; M024a = P457 * M020a which are properly scaled. Parameters P267/P267b (see coding of P267/P267b) sets the unit of measure for the measures above; the unit of measure can also be entered in parameter P267a/P267c (only if P267/P267b = 0: [Disable]).</p> <p>Example: the PID reference is 100%; M020 = 100%; if P257 = 0.04 and P267 = 1: [bar], the scaled measure for the PID reference is → M023 = 4.00 bar.</p>	

Table 21: Preset units of measure

Unit of Measure	P267/P267b P267s/P267u	Item Displayed	Unit of measure	P267/P267b P267s/P267u	Item Displayed
Customized	0: Disabled	----(see P267a/c)	m/s	20: m/s	m/s
bar	1: bar	bar	ft/s	21: ft/s	ft/s
mbar	2: mbar	mbar	rpm	22: rpm	rpm
atm	3: atm	atm	gal/s	23: GPS	GPS
Pa	4: Pa	Pa	gal/min	24: GPM	GPM
kPa	5: kPa	kPa	gal/h	25: GPH	GPH
PSI	6: PSI	PSI	ft ³ /s	26: CFS	CFS
m ³ /s	7: m ³ /s	m ³ /s	ft ³ /min	27: CFM	CFM
m ³ /min	8: m ³ /m	m ³ /m	ft ³ /h	28: CFH	CFH
m ³ /h	9: m ³ /h	m ³ /h	A	29: A	A
l/s	10: l/s	l/s	V	30: V	V
l/min	11: l/m	l/m	W	31: W	W
l/h	12: l/h	l/h	kW	32: kW	kW
°	13: °	°	HP	33: HP	HP
°C	14: °C	°C	CV	34: CV	CV
°F	15: °F	°F	kVA	35: kVA	kVA
Nm	16: Nm	Nm	ft-lbs	36: ftLb	ftLb
kgm	17: kgm	kgm	Polished Rod Speed	37: PRS	PRS
m	18: m	m	Polished Rod Torque	38: PRT	PRT
ft	19: ft	ft	stroke/min	39: SPM	SPM

P267a/P267c Custom PID/PID2 Units of Measure

P267a/P267c	Range	0x20 ÷ 0x8A (every byte)	ASCII 0x20 = blank ASCII 0x8A = □
	Default	0x015D255B	ASCII 0x5D = [ASCII 0x25 = % ASCII 0x5B =] ⇒ [%]
	Level	ENGINEERING	
	Address	1851/1865	(This is a 32-bit data item) Characters are 8-bit ASCII encoded; there are three 8-bit characters starting from the least significant bit. Bit 24 must always be set to 1.
	Function	Parameter P267a/P267c is active only if P267/P267b = 0: [Disable] and it relates to the unit of measure actually displayed in M023, M024, M023a, M024a . This parameter allows setting a 3-character string to display the units of measures for the PID Measures: M023, M024, M023a, M024a . Press the SAVE/ENTER key to edit each character: when a flashing cursor appears on the left of each character, press ▲ and ▼ to scroll all the characters displayed. Press the ESC key to go to the next character. Press SAVE/ENTER to store the new parameter value.	



NOTE See also parameter **P257/P457** in the PID PARAMETERS MENU.

P268 (P268a) Measure n.1 (n.2) on Root Page

P268 / P268a	Range	M000 ÷ M027a (see Table 23)
	Default	P268 → M004 Motor Spd P268a → M000 Speed Ref.
	Level	ADVANCED
	Address	Cannot be accessed via serial link.
	Function	These two parameters allow selecting two measures to be displayed on the Root Page.

P268y (P268z) Scaling of Measure n.1 (n.2) on Root Page

P268y / P268z	Range	0 ÷ 10000	0 ÷ 100.00%
	Default	10000	100.00%
	Level	ADVANCED	
	Address	515 / 516	
	Function	These parameters allow scaling the read-out of the measures on the Root page which have been selected with parameters P268 and P268a.	

P268b (P268c, P268d, P268e) Measure n.1 (n.2, n.3, n.4) on Keypad Pages

P268b, P268c, P268d, P268e	Range	M000 ÷ M027a (see Table 23)
	Default	P268b → M006 Mot.Freq. P268c → M026 Motor Current P268d → M004 Motor Spd P268e → M000 Speed Ref.
	Level	ADVANCED
	Address	Cannot be accessed via serial link.
	Function	These four parameters allow selecting four measures to be displayed on the Keypad Pages.

NOTE

Measure n. 4 is available in the measure Keypad page only. In the remaining Keypad pages st is substituted by the References / Feedback / Limits active in that page.

Table 22: List of the programmable measures for P268, P268a, P268b, P268c, P268d, P268e

M000 Speed Ref	M048 SerPID Fbk
M002 Ramp Out	M049 FbusPID Fbk
M004 Motor Speed	M050 Encoder Ref
M006 Mot.Freq.	M051 Freq.In Ref
M007 Torq.Ref	M056 Digital Out
M008 Torq.Demand	M057 Freq.Out
M009 Torq.Out	M058 Analog Out AO1
M010 Torq.Ref %	M059 Analog Out AO2
M011 Torq.Dem.%	M060 Analog Out AO3
M012 Torq.Out %	M061 Aux. Dig.OUT
M013 T.Lim.Ref	M062 Amb.Temp.
M014 T.Lim.RmpOut	M036a Aux.Ser. Dig.IN
M015 T.Lim.Ref %	M064 Hts.Temp.
M016 T.Lim.RmpOut %	M065 OT Counter
M017 Flux Ref	M066 ST Counter
M018 PID Ref %	M036b Aux.FBus. Dig.IN
M019 PID RmpOut %	M022a PID2 Out %
M020 PID Fbk %	M069 PT100 Temp.1
M021 PID Err %	M070 PT100 Temp.2
M022 PID Out %	M071 PT100 Temp.3
M023 PID Ref	M072 PT100 Temp.4
M024 PID Fbk	M028a Energy (low)
M056a Virtual Dig.Out	M013a Speed Lim Ref
M026 Mot.Current	M014a Speed Lim Out
M027 Out Volt	M026a I2t %
M028 Power Out	M039a Analog In XAIN4
M029 Vbus-DC	M039b Analog In XAIN5
M030 V Mains	M018a PID2 Ref %
M031 Delay.Dig.IN	M019a PID2 RmpOut %
M032 Istant.Dig.IN	M020a PID2 Fbk %
M033 Term. Dig.IN	M021a PID2 Err %
M034 Ser. Dig.IN	M023a PID2 Ref
M035 Fbus. Dig.IN	M024a PID2 Fbk
M036 Aux. Dig.IN	M090 Alarm
M037 Analog In REF	M056b Timed Flags TFL
M038 Analog In AIN1	M027a Power Factor
M039 Analog In AIN2	M004u Custom Mot. Speed
M040 Ser.SpdRef	M009u Custom Torq.Out
M042 Fbus.SpdRef	M120 Enc. A Pulses
M044 Ser.TrqLimRef	M121 Enc. B Pulses
M045 Fbus.TrqLimRef	
M046 SerPID Ref	
M047 FbusPID Ref	

P268s Custom Motor Speed unit of measure

P268s	Range	0 ÷ 39	See Table 21
	Default	0	0: [Disable]
	Level	ENGINEERING	
	Address	722	
	Function	It is the unit of measure used to display the speed of custom motor M004u .	

P268t Scaling of Custom Motor Speed

P268t	Range	0 ÷ 65535	0.00 ÷ 655.35 %
	Default	10000	100.00 %
	Level	ENGINEERING	
	Address	517	
	Function	It is the gain for scaling of the speed of custom motor M004u , with respect to the speed of motor M004 expressed in rpm. Example: If P268s = SPM and P268u = 0.6%, when M004 = 1000 rpm, M004u = 6 SPM.	

P268u Custom Torque unit of measure

P268u	Range	0 ÷ 39	See Table 21
	Default	0	0: [Disable]
	Level	ENGINEERING	
	Address	723	
	Function	It is the unit of measure used to display the torque of custom motor M009u .	

P268v Scaling of Custom Torque

P268t	Range	0 ÷ 65535	0.00 ÷ 655.35 %
	Default	10000	100.00 %
	Level	ENGINEERING	
	Address	518	
	Function	It is the gain for scaling of the torque of custom motor M009u , with respect to the speed of motor M009 expressed in Nm. Example: If P268u = ftLb and P268v = 73.75%, when M009 = 100 Nm, M009u = 73.75 ftLb.	

P269 Disable LOC/REM FWD/REV Keys

P269	Range	0 ÷ 3	0:[No No] - 3:[YES YES]
	Default	0	0:[No No]
	Level	ENGINEERING	
	Address	869	
	Function	<p>This parameter allows disabling the LOC/REM and/or the FWD/REV key. This is a bit-controlled parameter: bit 0 relates to LOC/REM, while bit 1 relates to FWD/REV. Set 0 to select [NO], set 1 to select [Yes].</p> <p>P269 = 0 → both keys are enabled. P269 = 1 → the LOC/REM key is disabled. P269 = 2 → the FWD/REV key is disabled. P269 = 3 → both keys are disabled.</p>	

P269b ESC Key to Restore Previous Value

P269b	Range	0 ÷ 1	0:[No] - 1:[YES]
	Default	0	0:[No]
	Level	ENGINEERING	
	Address	1051	
	Function	<p>Effect of pressing the ESC key when changing a parameter after pressing SAVE/ENTER:</p> <p>P269b = 0:[No] → press ESC to confirm the parameter value, which is not stored non-volatile memory (the previous value will be restored when the drive is next powered on). P269b = 1:[YES] → press ESC to restore the previous value. In both cases, press SAVE/ENTER to confirm the new parameter value and store it to non-volatile memory (the new value is still effective when the drive is next powered on).</p>	

12. RAMPS MENU

12.1. Overview

An acceleration/deceleration ramp is a function allowing linear variations of the motor speed.

The ramp time is the time the motor takes to reach its max. speed when it starts from zero speed (or the time the motor takes to reach 0 speed when decelerating).

Four pairs of programmable values are available. Each pair defines the motor acceleration time and deceleration time. The unit of measure of the basic time period is assigned to each pair of values.

In the Ramps menu, you can set the acceleration and deceleration times for the four speed ramps available for ordinary operation, for the torque ramp and the speed/torque ramp in JOG mode.

Using two special parameters, you can also set the start rounding off and the end rounding off for the acceleration ramps, while two different parameters allow setting the start rounding off and the end rounding off for the deceleration ramps. A fifth parameter allows selecting the ramps for the preset rounding off.

12.1.1. DESCRIPTION OF THE SPEED RAMPS

For the four speed ramps that can be selected through a combination of the digital inputs set in **C167** and **C168**, you can set the following: acceleration time, deceleration time and their units of measure, allowing increasing the programmable time range.

P009 Ramp Up Time 1

P010 Ramp Down Time 1

P012 Ramp Up Time 2

P013 Ramp Down Time 2

P014 Unit of Measure for Ramp Times 1 and 2

P015 Ramp Up Time 3

P016 Ramp Down Time 3

P018 Ramp Up Time 4

P019 Ramp Down Time 4

P020 Unit of Measure for Ramp Times 3 and 4

The set ramp time corresponds to the time the speed reference takes to reach the max. speed (from 0 rpm) as an absolute value between min. speed and max. speed of the selected motor (**C028** and **C029** for motor 1, and so on). The time unit of measure may have the following values:

0 → 0.01 s

1 → 0.1 s

2 → 1 s

3 → 10 s

The programmable range may be 0s – 327000s.

Example of a speed ramp:

Table 23: Example of a Speed Ramp

P014		Range P009 – P010	
Value	Coding	Min.	Max.
0	0.01 s	0	327.00 s
1	0.1 s	0	3270.0 s
2	1s	0	32700 s
3	10 s	0	327000 s

The factory setting of the unit of measure is 0.1 s; the ramp time is 10 sec.

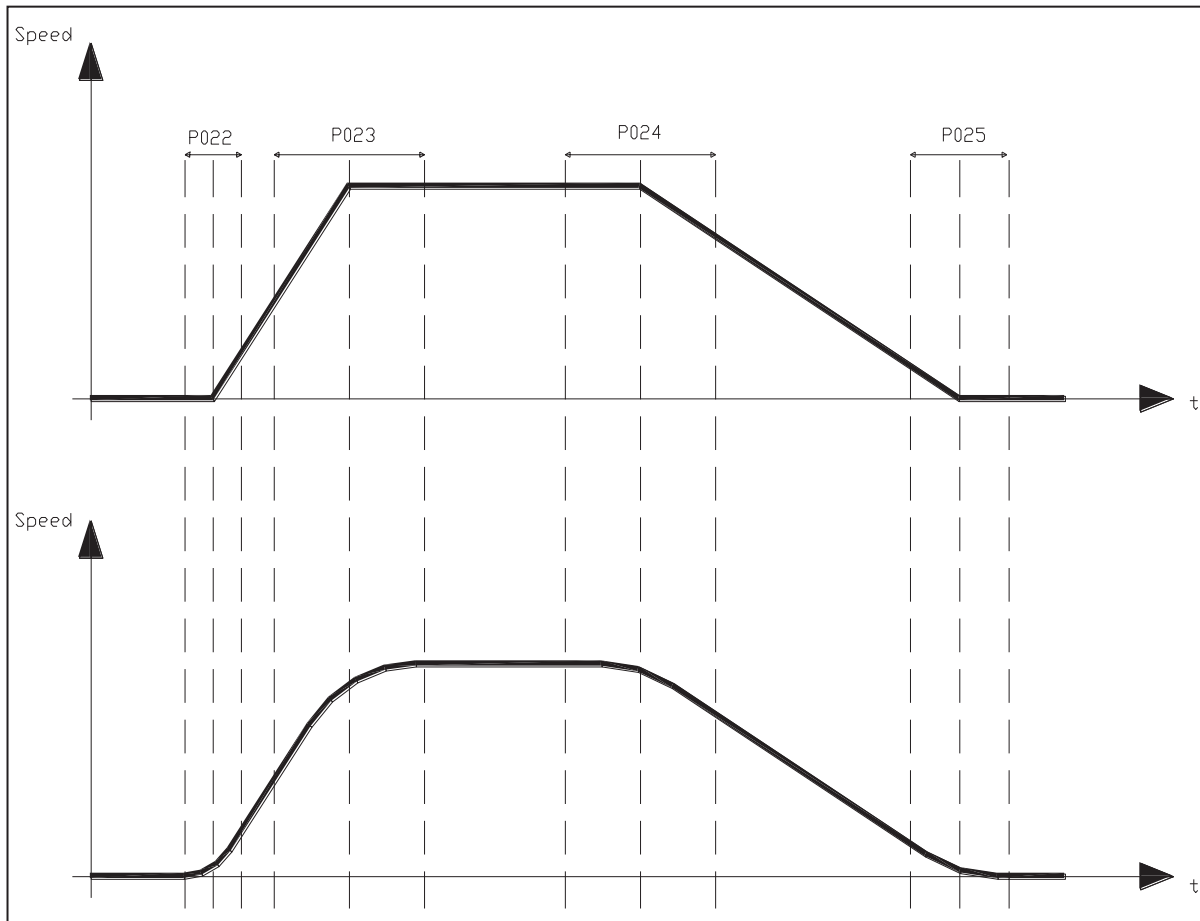

Figure 4: Example of S ramps

You can also select the rounding off and the rounding off percentage for the 4 stages of starting ramp up and the starting ramp down, and for the end ramp up and the end ramp down (S ramps). The limited jerk S-curve (jerk is the derivative of acceleration and a measure of impact) can be represented by a second-order polynomial in velocity. Limited Jerk S-curves are used to eliminate discontinuities in acceleration that are detrimental to mechanical gear.

The rounding off is expressed as a percentage of the ramp time it relates to; if used, it allows increasing the preset ramp time by half the sum value of the two rounding off values. Its effect is shown in the figures below.

Example: **P009** = 10sec ; **P021** = 1111 binary (rounding off selected for all four ramps); **P022** = 50%; **P023** = 50%

The resulting ramp up time is as follows:

$$\mathbf{P009} + ((\mathbf{P009} * (\mathbf{P022} + \mathbf{P023}) / 2) / 100) = 10 + ((10 * (50 + 50) / 2) / 100) = 15 \text{ sec}$$

The effect of this rounding off can be seen in the figures below:

The figure shows two patterns for the ramp reference. The first pattern is not rounded off; the second pattern has the same ramp times, but different rounding off values are applied to the start/end ramp up/down time.

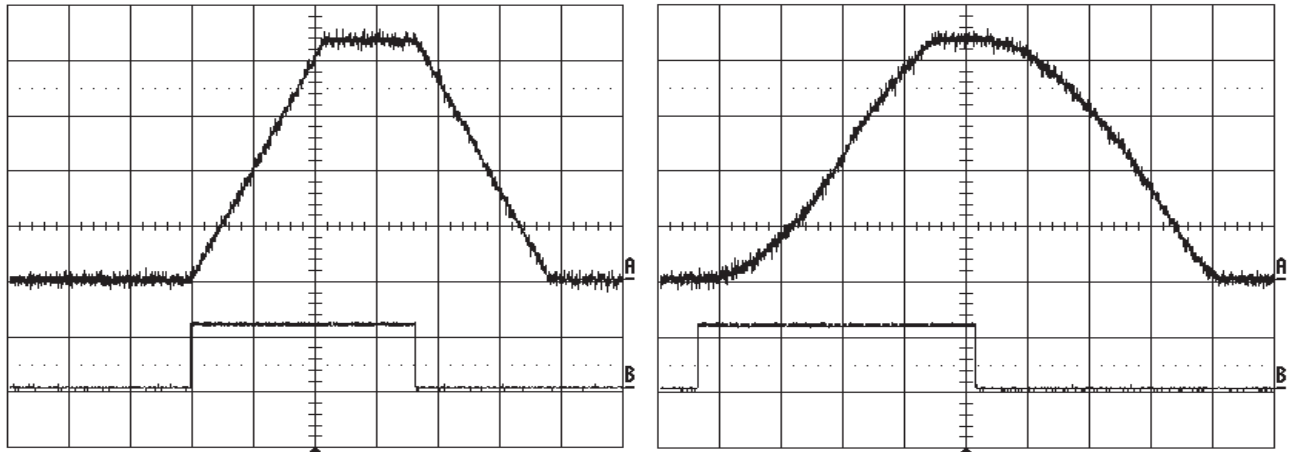

Figure 5: Speed profile without Rounding Off and with Rounding Off 2 (example)

In the figures above, the run command is represented by the high level of the second signal. Note that the time the reference takes to reach constant rpm depends not only on the ramp times, but also on the rounding off values you have defined.

Acceleration RESET function

This parameter has effect only if S ramps are used. Parameter **P031** enables to reset acceleration when reference trends change.

Whenever a speed reference trend changes, the motor acceleration is instantly set to zero and the ramp output reference will be computed considering the preset rounding off (see

Figure 6). The figure shows the instant when deceleration begins; the rounding off value assigned to the speed reference when the gradient changes is the value set for the deceleration starting stage.

If parameter **P031** is set to [No], acceleration is brought to zero before the speed reference starts decreasing, then deceleration begins with the preset pattern.

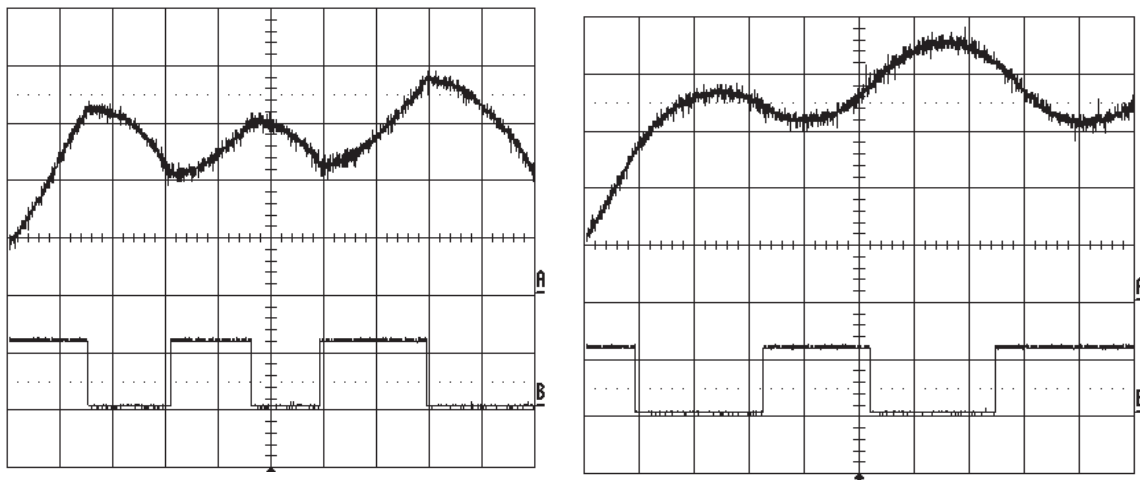

Figure 6: Speed profile with Acceleration Reset - Yes to No (Example)

12.1.2. DESCRIPTION OF THE TORQUE RAMPS

If the control algorithm is VTC or FOC and if it is controlled by setting “Torque” (**C011** for motor 1, **C054** for motor 2, and **C097** for motor 3 respectively), the reference is “ramped” based on the values set in parameter **P026** (torque increase ramp time), **P027** (torque decrease ramp time), and **P028** (unit of measure for the ramp times). The ramp up time setting is the time the output torque reference takes to go from 0 to the max. value (as an absolute value) between Torque min. and Torque max. of the selected motor (**C047**, **C048** for motor 1 and so on).

12.2. List of Parameters P009 to P033

Table 24: List of Parameters P009 to P033

Parameter	FUNCTION	User Level	Default Values	MODBUS Address
P009	Speed ramp 1: acceleration time	BASIC	See Table 82 and Table 86	609
P010	Speed ramp 1: deceleration time	BASIC	See Table 82 and Table 86	610
P012	Speed ramp 2: acceleration time	ADVANCED	See Table 82 and Table 86	612
P013	Speed ramp 2: deceleration time	ADVANCED	See Table 82 and Table 86	613
P014	Speed ramps 1 and 2: time unit of measure	ADVANCED	See Table 82 and Table 86	614
P015	Speed ramp 3: acceleration time	ADVANCED	See Table 82 and Table 86	615
P016	Speed ramp 3: deceleration time	ADVANCED	See Table 82 and Table 86	616
P018	Speed ramp 4: acceleration time	ADVANCED	See Table 82 and Table 86	618
P019	Speed ramp 4: deceleration time	ADVANCED	See Table 82 and Table 86	619
P020	Speed ramps 3 and 4: time unit of measure	ADVANCED	See Table 82 and Table 86	620
P021	Selection for S ramp rounding off	ADVANCED	1 [On]	621
P022	Acceleration S ramp: start rounding off time	ADVANCED	See Table 82 and Table 86	622
P023	Acceleration S ramp: end rounding off time	ADVANCED	See Table 82 and Table 86	623
P024	Deceleration S ramp: start rounding off time	ADVANCED	See Table 82 and Table 86	624
P025	Deceleration S ramp: end rounding off time	ADVANCED	See Table 82 and Table 86	625
P026	Torque ramp time: up	ADVANCED	5 s	626
P027	Torque ramp time: down	ADVANCED	5 s	627
P028	Unit of measure for torque ramp time	ADVANCED	0.1 s	628
P029	Jog ramp acceleration time	ADVANCED	1 s	629
P030	Jog ramp deceleration time	ADVANCED	1 s	629
P031	Gradient variation acceleration reset	ADVANCED	1 : [YES]	630
P032	Fire Mode Ramp: acceleration time	ENGINEERING	See Table 82 and Table 86	632
P033	Fire Mode Ramp: deceleration time	ENGINEERING	See Table 82 and Table 86	633

P009 Speed Ramp 1: Acceleration Time

P009	Range	0 ÷ 32700	0 ÷ 327.00 s if P014 =0 → 0.01 s 0 ÷ 3270.0 s if P014 =1 → 0.1 s 0 ÷ 32700 s if P014 =2 → 1 s 0 ÷ 327000 s if P014 =3 → 10 s
	Default	See Table 82 and Table 86	
	Level	BASIC	
	Address	609	
	Function	Determines the time the reference takes to go from 0 rpm to the max. preset speed (considering the max. value between absolute values for max. speed and min. speed set for the selected motor). If S ramps are used, the actual time the reference takes to reach constant rpm exceeds the time set in P009 for a percentage equal to $(P022+P023)/2$.	

P010 Speed Ramp 1: Deceleration Time

P010	Range	0 ÷ 32700	0 ÷ 327.00 s if P014 =0 → 0.01 s 0 ÷ 3270.0 s if P014 =0 → 0.1 s 0 ÷ 32700 s if P014 =0 → 1 s 0 ÷ 327000 s if P014 =0 → 10 s
	Default	See Table 82 and Table 86	
	Level	BASIC	
	Address	610	
	Function	Determines the time the reference takes to go from the max. preset speed (considering the max. value between absolute values for max. speed and min. speed set for the selected motor) to zero rpm. If S ramps are used, the actual time the reference takes to reach 0 speed exceeds the time set in P010 for a percentage equal to $(P024+P025)/2$.	

P012 Speed Ramp 2: Acceleration Time

P012	Range	0 ÷ 32700	0 ÷ 327.00 s if P014 =0 → 0.01 s 0 ÷ 3270.0 s if P014 =0 → 0.1 s 0 ÷ 32700 s if P014 =0 → 1 s 0 ÷ 327000 s if P014 =0 → 10 s
	Default	See Table 82 and Table 86	
	Level	ADVANCED	
	Address	612	
	Function	Same as ramp 1 (see P009).	



NOTE

Values for ramp 2 can be applied to the reference provided that multiramp digital inputs are set up and that ramp 2 is selected (see the DIGITAL INPUTS MENU).

P013 Speed Ramp 2: Deceleration Time

P013	Range	0 ÷ 32700	0 ÷ 327.00 s if P014 =0 → 0.01 s 0 ÷ 3270.0 s if P014 =0 → 0.1 s 0 ÷ 32700 s if P014 =0 → 1 s 0 ÷ 327000 s if P014 =0 → 10 s
	Default	See Table 82 and Table 86	
	Level	ADVANCED	
	Address	613	
	Function	Same as ramp 1 (see P010).	



NOTE

Values for ramp 2 can be applied to the reference provided that multiramp digital inputs are set up and that ramp 2 is selected (see the DIGITAL INPUTS MENU).

P014 Speed Ramps 1 and 2: Time Unit of Measure

P014	Range	0 ÷ 3	0 → 0.01 s 1 → 0.1 s 2 → 1 s 3 → 10 s
	Default	See Table 82 and Table 86	
	Level	ADVANCED	
	Address	614	
	Function	Defines the unit of measure for the time periods for speed ramp 1 (P009 and P010), for speed ramp 2 (P012 and P013), and for ramps in Fire Mode (P032 and P033). The allowable programmable range may be extended from 0 s to 327000s. E.g. P014 =1 then P009 =100; this means P009 = 100 x 0.1 s = 10 s P014 =0 then P009 =100; this means P009 = 100 x 0.01 s = 1 s P014 =3 then P009 =100; this means P009 = 100 x 10 s = 1000 s	

P015 Speed Ramp 3: Acceleration Time

P015	Range	0 ÷ 32700	0 ÷ 327.00 s if P020 =0 → 0.01 s 0 ÷ 3270.0 s if P020 =0 → 0.1 s 0 ÷ 32700 s if P020 =0 → 1 s 0 ÷ 327000 s if P020 =0 → 10 s
	Default	See Table 82 and Table 86	
	Level	ADVANCED	
	Address	615	
	Function	Same as ramp 1 (see P009).	



NOTE

Values for ramp 3 can be applied to the reference provided that multiramp digital inputs are set up and that ramp 3 is selected (see the DIGITAL INPUTS MENU).

P016 Speed Ramp 3: Deceleration Time

P016	Range	0 ÷ 32700	0 ÷ 327.00 s if P020 =0 → 0.01 s 0 ÷ 3270.0 s if P020 =0 → 0.1 s 0 ÷ 32700 s if P020 =0 → 1 s 0 ÷ 327000 s if P020 =0 → 10 s
	Default	See Table 82 and Table 86	
	Level	ADVANCED	
	Address	616	
	Function	Same as ramp 1 (see P010).	



NOTE

Values for ramp 3 can be applied to the reference provided that multiramp digital inputs are set up and that ramp 3 is selected (see the DIGITAL INPUTS MENU).

P018 Speed Ramp 4: Acceleration Time

P018	Range	0 ÷ 32700	0 ÷ 327.00 s if P020 =0 → 0.01 s 0 ÷ 3270.0 s if P020 =0 → 0.1 s 0 ÷ 32700 s if P020 =0 → 1 s 0 ÷ 327000 s if P020 =0 → 10 s
	Default	See Table 82 and Table 86	
	Level	ADVANCED	
	Address	618	
	Function	Same as ramp 1 (see P009).	



NOTE

Values for ramp 4 can be applied to the reference provided that multiramp digital inputs are set up and that ramp 4 is selected (see the DIGITAL INPUTS MENU).

P019 Speed Ramp 4: Deceleration Time

P019	Range	0 ÷ 32700	0 ÷ 327.00 s if P020 =0 → 0.01 s 0 ÷ 3270.0 s if P020 =0 → 0.1 s 0 ÷ 32700 s if P020 =0 → 1 s 0 ÷ 327000 s if P020 =0 → 10 s
	Default	See Table 82 and Table 86	
	Level	ADVANCED	
	Address	619	
	Function	Same as ramp 1 (see P010).	



NOTE

Values for ramp 4 can be applied to the reference provided that multiramp digital inputs are set up and that ramp 4 is selected (see the DIGITAL INPUTS MENU).

P020 Speed Ramps 3 and 4: Time Unit of Measure

P020	Range	0 ÷ 3	0 → 0.01 s 1 → 0.1 s 2 → 1 s 3 → 10 s
	Default	See Table 82 and Table 86	
	Level	ADVANCED	
	Address	620	
	Function	Defines the unit of measure for the times for speed ramp 3, P015 and P016 , and speed ramp 4, P020 and P018 . The allowable programmable range may be extended from 0 s to 327000s.	

P021 Selection for Ramp Rounding Off

P021	Range	0000b ÷ 1111b binary 0x0000 ÷ 0x000F hexadecimal 0 ÷ 15	0000b (no S ramps) 1111b (all S ramps)
	Default	1111b (all S ramps)	
	Level	ADVANCED	
	Address	621	
	Function	In this parameter, you can select the bit corresponding to the ramp to be rounded off. Example: P021 = 0011b = 3 decimal → ramps 1 and 2 are rounded off. The ramp rounding off allows reaching the reference end value with a zero tangent, both while accelerating and while decelerating, thus suppressing torque peaks that could damage mechanical couplings.	

P022 Acceleration Ramp: Start Rounding Off Time

P022	Range	0 ÷ 100	0 ÷ 100 %
	Default	See Table 82 and Table 86	
	Level	ADVANCED	
	Address	622	
	Function	Sets the rounding off time period for the first stage of the acceleration ramp. This parameter is expressed as a percentage of the acceleration ramp time of the active ramp. Example: the second ramp is active with an acceleration ramp time of 5 secs, P022 = 50%. Therefore, reference acceleration is limited for the first 2.5 secs of the ramp time.	



NOTE

When using parameter **P022**, the preset acceleration ramp time is increased by: $(P022\%)/2$.

P023 Acceleration Ramp: End Rounding Off Time

P023	Range	0 ÷ 100	0 ÷ 100 %
	Default	See Table 82 and Table 86	
	Level	ADVANCED	
	Address	623	
	Function	Sets the rounding off time period for the end stage of the acceleration ramp. This parameter is expressed as a percentage of the acceleration ramp time of the active ramp.	



NOTE

When using parameter **P023**, the preset acceleration ramp time is increased by: **(P023%)/2**.

P024 Deceleration Ramp: Start Rounding Off Time

P024	Range	0 ÷ 100	0 ÷ 100 %
	Default	See Table 82 and Table 86	
	Level	ADVANCED	
	Address	624	
	Function	See the function for P022 . The only difference is that this rounding off function is applied to the first stage of a deceleration ramp.	



NOTE

When using parameter **P024**, the preset deceleration ramp time is increased by: $(P024\%)/2$.

P025 Deceleration Ramp: End Rounding Off Time

P025	Range	0 ÷ 100	0 ÷ 100 %
	Default	See Table 82 and Table 86	
	Level	ADVANCED	
	Address	625	
	Function	See the function for P023 . The only difference is that this rounding off function is applied to the last stage of a deceleration ramp.	



NOTE

When using parameter **P025**, the preset deceleration ramp time is increased by: $(P025\%)/2$.

P026 Torque Ramp Time: Up

P026	Range	0 ÷ 32700	Function of P028
	Default	500	50 sec
	Level	ADVANCED	
	Address	626	
	Function	Defines the time taken by the torque reference of the selected motor to go to zero from max. value (as an absolute value between Torque min. and Torque max.); (C047–C048 for motor 1 and so on).	

P027 Torque Ramp Time: Down

P027	Range	0 ÷ 32700	Function of P028
	Default	500	50 sec
	Level	ADVANCED	
	Address	627	
	Function	Defines the time taken by the torque reference of the selected motor to go from max. value to zero (as an absolute value between Torque min. and Torque max.); (C047–C048 for motor 1 and so on).	

P028 Unit of Measure for Torque Ramp Time

P028	Range	0 ÷ 3	0 → 0.01 s 1 → 0.1 s 2 → 1 s 3 → 10 s
	Default	1	1 → 0.1 s
	Level	ADVANCED	
	Address	628	
	Function	Defines the unit of measure for the torque ramp times. See the unit of measure for ramp 1 (par. P014).	

P029 Jog Ramp Acceleration Time

P029	Range	0 ÷ 6500	0 ÷ 6500 sec
	Default	1	1sec
	Level	ADVANCED	
	Address	629	
	Function	The preset time corresponds to the time the “ramped” speed/torque reference takes to go from zero to the JOG speed/torque value (P070).	

P030 Jog Ramp Deceleration Time

P030	Range	0 ÷ 6500	0 ÷ 6500 sec
	Default	1	1sec
	Level	ADVANCED	
	Address	630	
	Function	The preset time corresponds to the time the “ramped” speed/torque reference takes to go from the JOG speed/torque value (P070) to zero.	

P031 Gradient Variation Acceleration Reset

P031	Range	0 ÷ 1	0: [No] ; 1: [Yes]
	Default	1	1: [Yes]
	Level	ADVANCED	
	Address	631	
	Function	Defines whether acceleration is reset or not when switching from acceleration to deceleration and vice versa (reference gradient). For more details, see the description of the speed ramps at the beginning of this section.	



NOTE Parameter **P031** is interlocked with parameter **C210** (Automatic extension of down ramp) so that **P031 = 0:No** cannot be programmed in conjunction with **C210 ≠ [With resistor]**.

P032 Fire Mode Acceleration Ramp

P032	Range	0 ÷ 32700	0 ÷ 327.00 s if P014 =0 → 0.01 s 0 ÷ 3270.0 s if P014 =1 → 0.1 s 0 ÷ 32700 s if P014 =2 → 1 s 0 ÷ 327000 s if P014 =3 → 10 s
	Default Level	See Table 82 and Table 86	
	Address	632	
	Function	This ramp is used to accelerate the motor when in Fire Mode.	

P033 Fire Mode Deceleration Ramp

P033	Range	0 ÷ 32700	0 ÷ 327.00 s if P014 =0 → 0.01 s 0 ÷ 3270.0 s if P014 =1 → 0.1 s 0 ÷ 32700 s if P014 =2 → 1 s 0 ÷ 327000 s if P014 =3 → 10 s
	Default Level	See Table 82 and Table 86	
	Address	633	
	Function	This ramp is used to decelerate the motor when in Fire Mode.	

13. INPUTS FOR REFERENCES MENU

13.1. Processing Speed/Torque References

The “**main reference**” is the value, at constant rpm, for the controlled physical variable (speed or torque) (**M000, M007**) “required” for the drive.

This reference is acquired by the drive only if the **START** command is active and the drive is **RUNNING**, otherwise it is ignored.

The **main reference** is the reference at constant rpm: when the drive is **RUNNING**, it will increment the speed or torque **set-point** which will reach the main reference with a timed ramp (see the RAMPS MENU).

The drive operating mode is factory-set to **MASTER** with a speed reference. In **SLAVE** mode, a torque reference is used; this operating mode may be configured for **VTC** control (Vector Torque Control) and **FOC** control (Field Oriented Control) only.

The **control algorithm** and the **MASTER/SLAVE mode** can be set for each of the 3 programmable motors, depending on which motor is active at that moment (motor 1, motor 2 or motor 3).

To enable the **SLAVE** mode, set the following parameters to **1** or **2**:

C011 (motor 1)

C054 (motor 2)

C097 (motor 3)

The SLAVE mode may also be selected through a digital input (see the DIGITAL INPUTS MENU).

When the main reference is acquired by the drive (**RUNNING** on), it becomes the reference for the time ramps generating the current speed/torque set-point for the connected motor.

The setup of the main reference is based on a number of parameters included in several menus:

Table 25: Parameters used for the Inputs for References Menu

Parameters	Menu	Contents
P050 ÷ P074	References	Scaling parameters for references sent from analog inputs REF, AIN1, AIN2. Scaling parameters for references sent from encoder and frequency input. Parameters for changes made using the UP and DOWN keys. Parameter for JOG reference setting. Parameter for drive disabling in case of reference at min. value.
P390 ÷ P399	References from optional board	Scaling parameters for references sent from analog inputs XAIN4, XAIN5.
P080 ÷ P098	Multispeed	Parameters setting preset multispeed values to be selected through digital inputs.
P105 ÷ P108	Prohibit Speed	Parameters setting prohibit speed values.
P115 ÷ P121	Reference Variation Percent	Parameters setting slowing down values percent to be selected through digital inputs.
C143 ÷ C146	Control Method	Parameters setting the reference source.
C011, C028, C029	Configuration of Motor 1	Parameter setting the Master (speed) mode or the Slave (torque) mode. Parameters setting the min. speed or the max. speed.
C054, C071, C072	Configuration of Motor 2	
C097, C114, C115	Configuration of Motor 3	
C047, C048	Limit for Motor 1	Parameters setting the min. torque and the max. torque.
C090, C091	Limit for Motor 2	
C133, C134	Limit for Motor 3	

The following pages contain block diagrams illustrating speed reference processing (Figure 7) and torque reference processing (Figure 8). Menus and parameters used are also stated.

Speed Reference computing

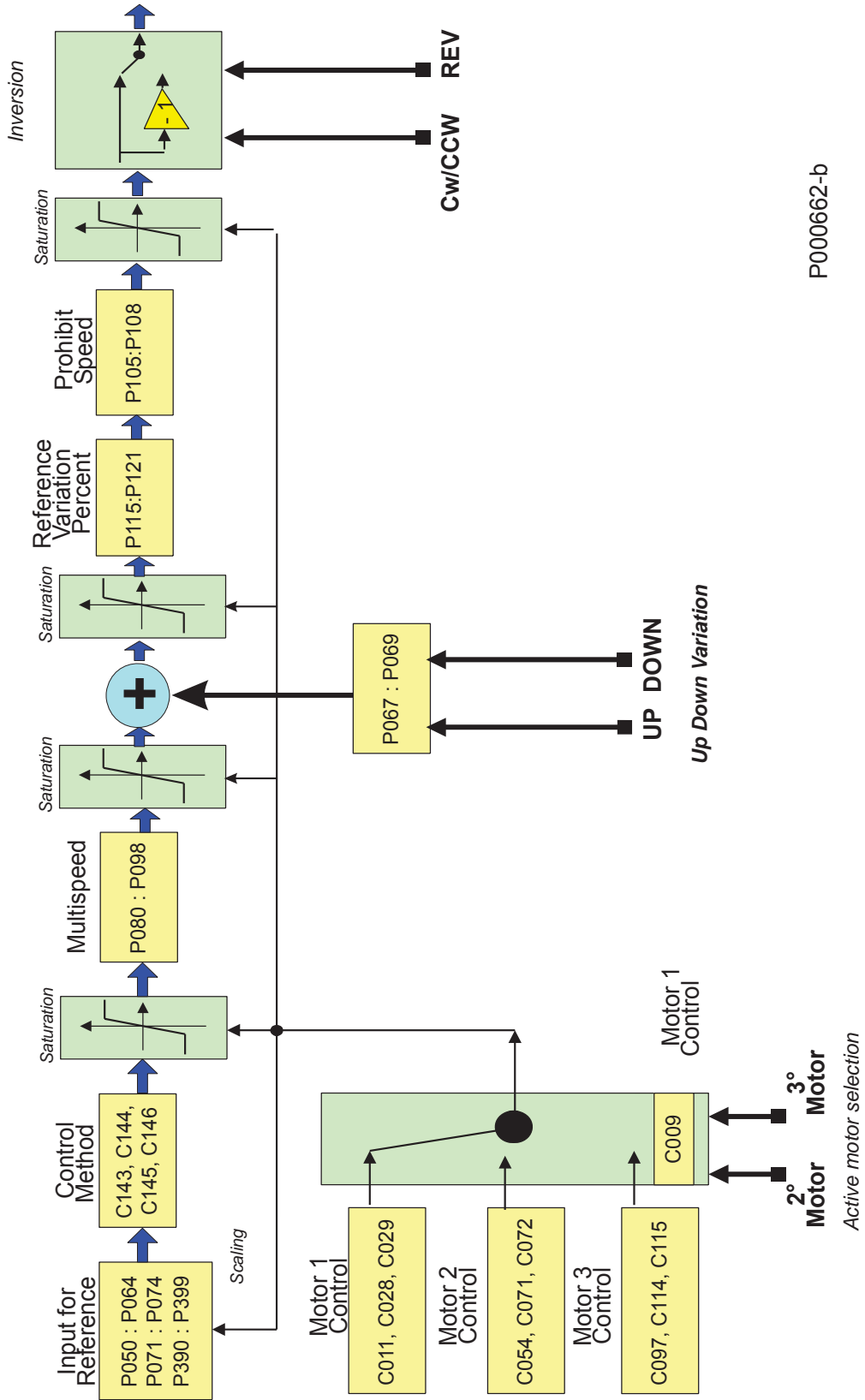

P000662-b

Figure 7: Speed Reference computing

Torque Reference computing

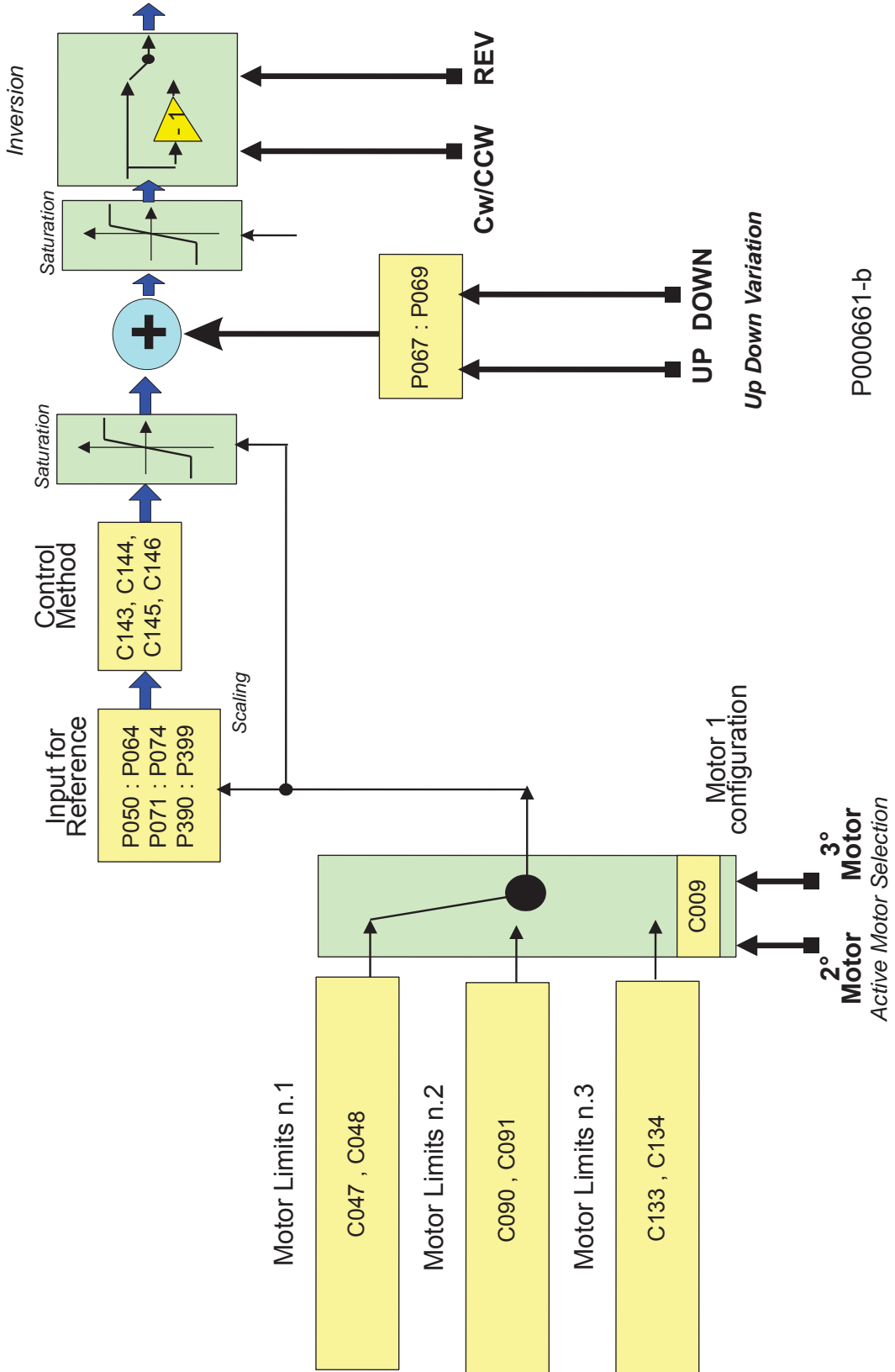

P000661-b

Figure 8: Torque Reference computing

13.2. Scaling Analog Inputs REF, AIN1, AIN2



NOTE Please refer to the Sinus Penta's Installation Guide for hardware details about analog inputs.

Three analog inputs are available: **REF**, **AIN1**, **AIN2**.

They can be voltage inputs or current inputs (switching is made possible through hardware DIP-Switch **SW1** and software parameters) and are bipolar analog inputs ($-10V \div +10V$ or $-20mA \div +20mA$).

REF input is single-ended; **AIN1** and **AIN2** inputs are differential inputs.

Factory setting is as follows: the **main speed reference** is given by **REF** analog input, **0V \div +10V** mode; only motor 1 is active. Its max. speed and min. speed parameters are **C088=1500** rpm and **C029=0** rpm respectively.

For the 3 analog inputs, parameters **P050 \div P064** allow setting the type of signal to be acquired, offset compensation (if any), scaling to obtain a speed reference or a torque reference, the signal filtering time constant.

Parameter **P053** sets the offset of the input analog signal (if **P053=0** offset is zero), while parameter **P054** defines the filtering time constant (factory setting: **P054 = 5ms**).

Type of input: for each analog input, DIP-Switch **SW1** allows setting the acquisition method of the input signal: voltage signal or current signal.

The voltage signal can be bipolar ($-10V \div +10V$) or unipolar (**0V \div +10V**).

The current signal can be bipolar ($-20mA \div +20mA$), unipolar (**0mA \div +20mA**) or can have a minimum offset (**4mA \div 20mA**).

The user will set each analog input mode in parameters **P050**, **P055**, **P060**.

Table 26: Analog Input Hardware Mode

Type / Terminals	Name	Type	DIP-Switch	Parameter
Single-ended input / 1,2	REF	$\pm 10V$ Input	SW1-1 off	P050
		0-20mA Input	SW1-1 on	
Differential input / 5,6	AIN1	$\pm 10V$ Input	SW1-2 off	P055
		0-20mA Input	SW1-2 on	
Differential input / 7,8	AIN2	$\pm 10V$ Input	SW1-3 off, SW1-4 5 off	P060
		0-20mA Input	SW1-3 on, SW1-4 5 off	
		PTC Input	SW1-3 off, SW1-4 5 on	See note



NOTE If AIN2 input is configured as PTC, refer to the MOTOR THERMAL PROTECTION MENU to select the proper parameters. Its measures are no longer valid.



NOTE Configurations different from the ones stated in the table above are not allowed.



CAUTION For each analog input (REF, AIN1, AIN2), make sure that the "mode" parameter setting (**P050**, **P055**, **P060**) matches with the setting of the relevant SW1 DIP-Switches.

Scaling is obtained by setting the parameters relating to the **linear function for the conversion** from the value read by the analog input to the corresponding speed/torque reference value.

The **conversion function** is a **straight line** passing through **2 points** in **Cartesian coordinates** having the values read by the analog input in the X-axis, and the speed/torque reference values multiplied by the reference percentage parameters in the Y-axis.

Each point is detected through its **two coordinates**.

The ordinates of the two points are the following:

the value of **Speed_Min** (or **Trq_Min** for the torque reference) multiplied by the percentage set through **P051a/P056a/P061a/P071a/P073a** for the **first point**; the value of **Speed_Max** (or **Trq_Max** for the torque reference) multiplied by the percentage set through **P052a/P057a/P062a/P072a/P074a** for the **second point**.

Speed_Min depends on the selected motor: see parameter **C028** (motor 1), **C071** (motor 2), or **C114** (motor 3).
Trq_Min depends on the selected motor: see parameter **C047** (motor 1), **C090** (motor 2) or **C133** (motor 3).

Speed_Max depends on the selected motor: see parameter **C029** (motor 1), **C072** (motor 2) or **C115** (motor 3).
Trq_Max depends on the selected motor: see parameter **C048** (motor 1), **C091** (motor 2), or **C134** (motor 3).

The X-axis values of the two points depend on the analog input:

REF Input:

Parameter **P051** is the X-axis value of the **first point**; parameter **P052** is the X-axis value of the **second point**.

AIN1 Input:

Parameter **P056** is the X-axis value of the **first point**; parameter **P057** is the X-axis value of the **second point**.
Input **AIN2**:

Parameter **P061** is the X-axis value of the **first point**; parameter **P062** is the X-axis value of the **second point**.

The figure below illustrates how parameters set computing the signals for speed (or torque) analog reference.

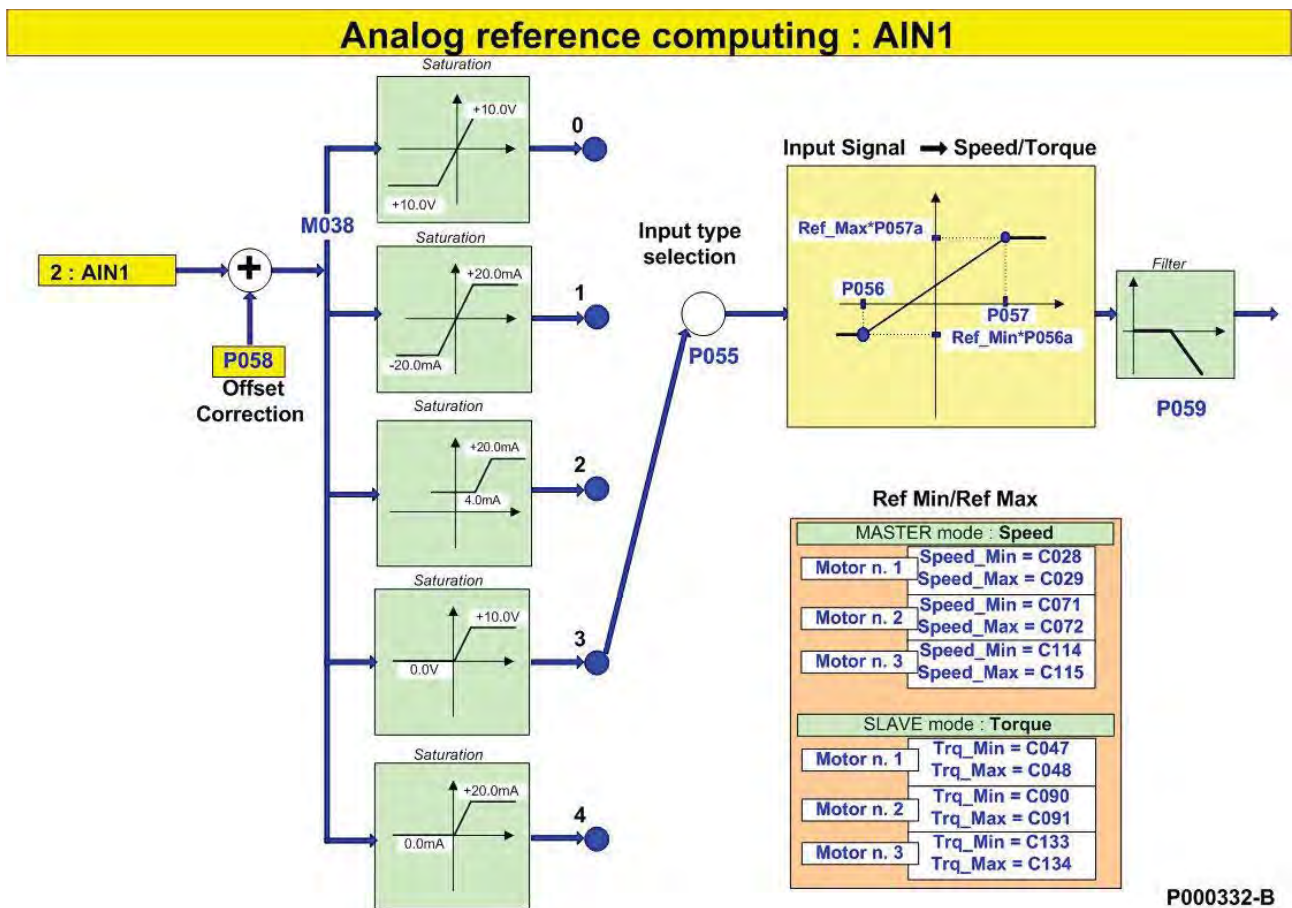
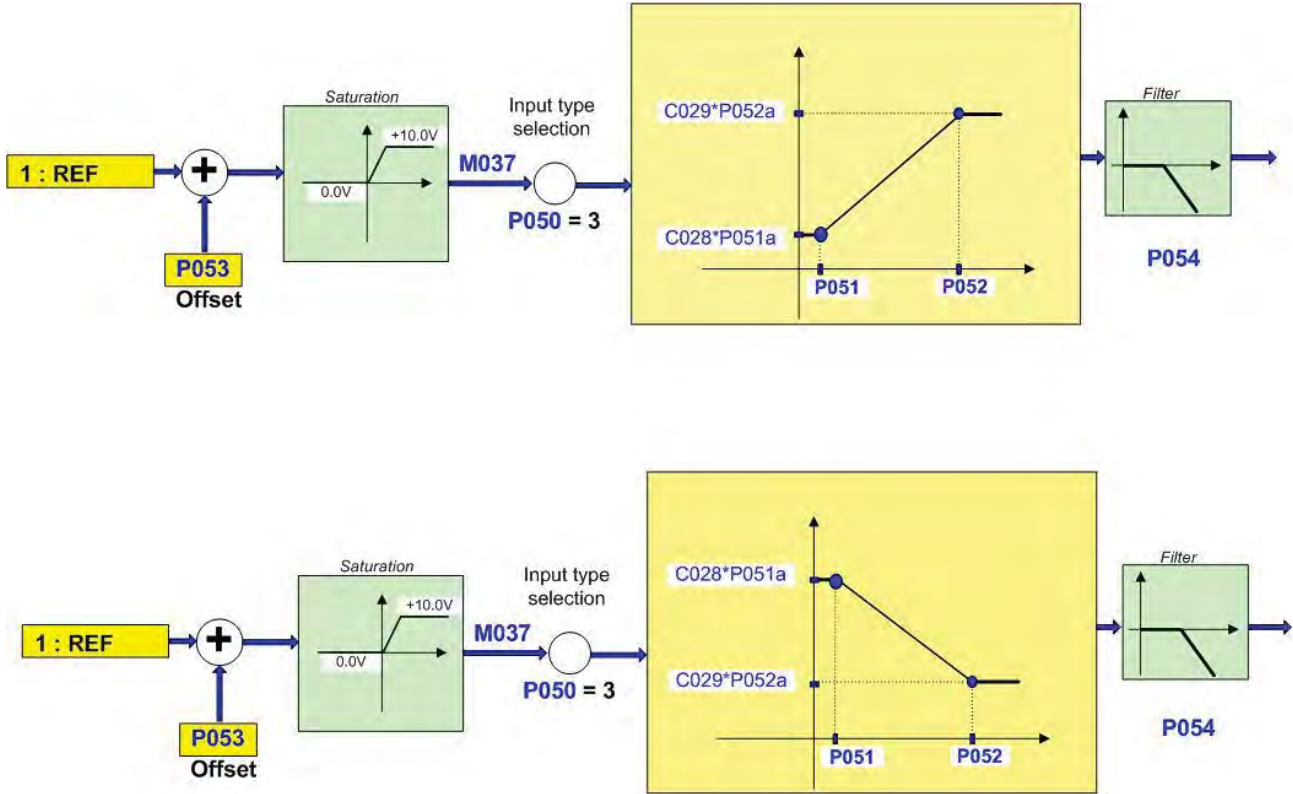

Figure 9: Computing Speed Analog Reference from terminal board: AIN1

The figures below illustrate programming examples for REF analog input, if motor 1 is selected and in MASTER mode: speed reference.



P000333-B

Figure 10: Computing Inputs REF (1) and (2) (examples)

The setup in the first part of the figure is as follows:

P050 = 3
P051 = 1V; P051a = 100%; P052 = 10V; P052a = 100%
Speed_Min = C028 = 100 rpm; Speed_Max = C029 = 1100 rpm

The setup in the second part of the figure is as follows:

P050 = 3
P051 = 1V; P051a = 100%; P052 = 10V; P052a = 100%
Speed_Min = C028 = 1200 rpm; Speed_Max = C029 = 400 rpm

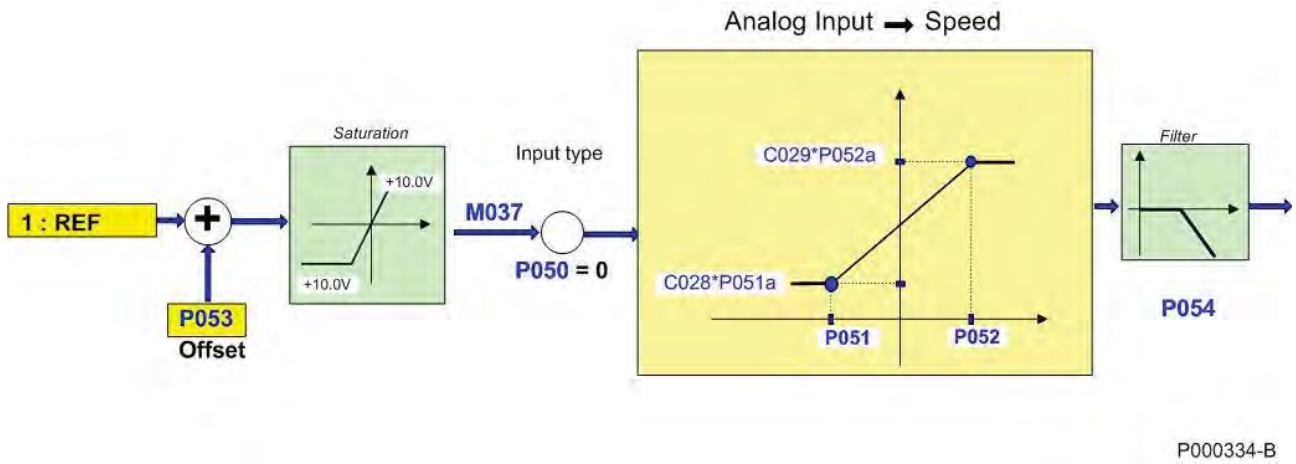

Figure 11: Computing REF Input (Example 3)

The Setup in Figure 11 is as follows:

P050 = 0

P051 = -5V; P051a = 100%; P052 = +8V; P052a = 100%

Speed_Min = C028 = 300 rpm; Speed_Max = C029 = 1450 rpm

13.3. List of Parameters P050 to P074a

Table 27: List of Parameters P050 to P074a

Parameter	FUNCTION	User Level	DEFAULT VALUE	MODBUS Address
P050	Type of signal over REF input	ADVANCED	3: 0÷10V	650
P051	Value of REF input producing min. reference (X-axis)	ADVANCED	0.0V	651
P051a	Percentage of Speed_Min/Trq_Min producing min. reference (Y-axis related to P051)	ADVANCED	100.0%	675
P052	Value of REF input producing max. reference (X-axis)	ADVANCED	10.0V	652
P052a	Percentage of Speed_Max/Trq_Max producing max. reference (Y-axis related to P052)	ADVANCED	100.0%	676
P053	Offset over REF input	ADVANCED	0V	653
P054	Filtering time over REF input	ADVANCED	5 ms	654
P055	Type of signal over AIN1 input	ADVANCED	2: 4÷20mA	655
P056	Value of AIN1 input producing min. reference (X-axis)	ADVANCED	4.0mA	656
P056a	Percentage of Speed_Min/Trq_Min producing min. reference (Y-axis related to P056)	ADVANCED	100.0%	677
P057	Value of AIN1 input producing max. reference (X-axis)	ADVANCED	20.0mA	657
P057a	Percentage of Speed_Max/Trq_Max producing max. reference (Y-axis related to P057)	ADVANCED	100.0%	678
P058	Offset over AIN1 input	ADVANCED	0mA	658
P059	Filtering time over AIN1 input	ADVANCED	5 ms	659
P060	Type of signal over AIN2 input	ADVANCED	2: 4÷20mA	660
P061	Value of AIN2 input producing min. reference (X-axis)	ADVANCED	4.0mA	661
P061a	Percentage of Speed_Min/Trq_Min producing min. reference (Y-axis related to P061)	ADVANCED	100.0%	679
P062	Value of AIN2 input producing max. reference (X-axis)	ADVANCED	20.0mA	662
P062a	Percentage of Speed_Max/Trq_Max producing max. reference (Y-axis related to P062)	ADVANCED	100.0%	701
P063	Offset over AIN2 input	ADVANCED	0mA	663
P064	Filtering time over AIN2 input	ADVANCED	5 ms	664
P065	Minimum reference and START disabling threshold	ADVANCED	0	665
P066	START disable delay at P065 threshold	ADVANCED	0s	666
P067	Keypad and terminal board UP/DOWN ramp	ADVANCED	Quadratic	667
P068	Storage of UP/DOWN values at Power Off	ADVANCED	YES	668
P068a	Reset UP/DOWN speed/torque at Stop	ADVANCED	0:[NO]	940
P068b	Reset UP/DOWN PID at Stop	ADVANCED	0:[NO]	941
P068c	Reset UP/DOWN speed/torque at Source Changeover	ADVANCED	0:[NO]	942
P068d	Reset UP/DOWN PID at Source Changeover	ADVANCED	0:[NO]	943
P069	Range of UP/DOWN reference	ADVANCED	1: Unipolar	669
P070	Jog reference (speed/torque)	ADVANCED	0%	670
P071	Value of FIN producing min. reference (X-axis)	ADVANCED	10 kHz	671
P071a	Percentage of Speed_Min/Trq_Min producing min. reference (Y-axis related to P071)	ADVANCED	100.0%	713
P072	Value of FIN producing max. reference (X-axis)	ADVANCED	100 kHz	672
P072a	Percentage of Speed_Max/Trq_Max producing max. reference (Y-axis related to P072)	ADVANCED	100.0%	714
P073	Value of ECH producing min. reference (X-axis)	ADVANCED	0 rpm	673
P073a	Percentage of Speed_Min/Trq_Min producing min. reference (Y-axis related to P073)	ADVANCED	100.0%	702
P074	Value of ECH producing max. reference (X-axis)	ADVANCED	+1500 rpm	674
P074a	Percentage of Speed_Max/Trq_Max producing max. reference (Y-axis related to P074)	ADVANCED	100.0%	703

**SINUS PENTA
PENTA MARINE**



PROGRAMMING GUIDE

P050 Type of Signal over REF Input

P050	Range	0 ÷ 4	0: ± 10 V 1: ± 20 mA 2: 4 ÷ 20 mA 3: 0 ÷ 10 V 4: 0 ÷ 20 mA
	Default	3	3: 0 ÷ 10 V
	Level	ADVANCED	
	Address	650	
	Function	<p>This parameter selects the type of single-ended, analog signal over the REF terminal in the terminal board. The signal can be a voltage signal, a current signal, a unipolar signal, or a bipolar signal.</p> <p>0: ± 10 V Bipolar voltage input between -10V and +10V. The detected signal is saturated between these two values.</p> <p>1: ± 20 mA Bipolar current input between -20mA and +20mA. The detected signal is saturated between these two values.</p> <p>2: 4 ÷ 20 mA Unipolar current input with min. threshold, between +4 mA and +20mA. The detected signal is saturated between these two values.</p> <p>Before being saturated, if the detected signal is lower than 4 mA or greater than 20 mA, alarms A066 or A102 trip.</p> <p>3: 0 ÷ 10 V Unipolar voltage input between 0V and +10V. The detected signal is saturated between these two values.</p> <p>4: 0 ÷ 20 mA Unipolar current input between +0 mA and +20mA. The detected signal is saturated between these two values.</p>	



NOTE

The value set in parameter **P050** must match with the status of **SW1-1** switch allowing selecting the proper electric circuit for the analog signal processing (voltage signal or current signal).

P051 Value of REF Input Producing Min. Reference (X-axis)

P051	Range	-100 ÷ 100, if P050 = 0 -200 ÷ 200, if P050 = 1 +40 ÷ 200, if P050 = 2 0 ÷ 100, if P050 = 3 0 ÷ 200, if P050 = 4	-10.0 V ÷ 10.0 V, if P050 = 0: ± 10 V -20.0 mA ÷ 20.0 mA, if P050 = 1: ± 20 mA +4.0mA ÷ 20.0 mA, if P050 = 2: 4 ÷ 20 mA 0.0 V ÷ 10.0V, if P050 = 3: 0 ÷ 10 V 0.0 mA ÷ 20.0 mA, if P050 = 4: 0 ÷ 20 mA
	Default	0	0 V
	Level	ADVANCED	
	Address	651	
	Function	<p>This parameter selects the value for REF input signal for minimum reference, or better the reference set in C028xP051a (Master mode) or in C047xP051a (Slave mode). If motor 2 is active, C071 and C090 will be used instead of C028 and C047; if motor 3 is active, the values set in C114 and C133 will be used.</p>	

P051a Percentage of Speed Min/Trq Min Producing Min. Reference (Y-axis related to P051)

P051a	Range	0 ÷ 1000	100.0%
	Default	1000	100.0%
	Level	ADVANCED	
	Address	675	
	Function	<p>This parameter represents the min. speed percentage (or the min. torque percentage for a torque reference) to be used for the minimum reference set with P051.</p>	

P052 Value of REF Input Producing Max. Reference (X-axis)

P052	Range	-100 ÷ 100, if P050 = 0 -200 ÷ 200, if P050 = 1 +40 ÷ 200, if P050 = 2 0 ÷ 100, if P050 = 3 0 ÷ 200, if P050 = 4	-10.0 V ÷ 10.0 V, if P050 = 0: ± 10 V -20.0 mA ÷ 20.0 mA, if P050 = 1: ± 20 mA +4.0mA ÷ 20.0 mA, if P050 = 2: 4 ÷ 20 mA 0.0 V ÷ 10.0V, if P050 = 3: 0 ÷ 10 V 0.0 mA ÷ 20.0 mA, if P050 = 4: 0 ÷ 20 mA
	Default	100	10.0 V
	Level	ADVANCED	
	Address	652	
	Function	This parameter selects the value for REF input signal for maximum reference, or better the reference set in C029xP052a (Master mode) or in C048xP052a (Slave mode). If motor 2 is active, C072 and C091 will be used instead of C029 and C048 ; if motor 3 is active, the values set in C115 and C134 will be used.	

P052a Percentage of Speed Max/Trq Max Producing Max. Reference (Y-axis related to P052)

P052a	Range	0 ÷ 1000	100.0%
	Default	1000	100.0%
	Level	ADVANCED	
	Address	676	
	Function	This parameter represents the max. speed percentage (or the max. torque percentage for a torque reference) to be used for the maximum reference set with P052 .	

P053 Offset over REF Input

P053	Range	-2000 ÷ 2000	-10.00 V ÷ +10.00 V, if P050 = 0 or 3 - 20.00 mA ÷ +20.00 mA, if P050 = 1,2,4
	Default	0	0 V
	Level	ADVANCED	
	Address	653	
	Function	This parameter selects the offset correction value of the REF analog signal that has been measured. The value set is added to the signal measured before saturation or conversion; its unit of measure is the same as the one of the signal selected for REF analog input.	

P054 Filtering Time over REF Input

P054	Range	0 ÷ +65000	0 ÷ +65000ms
	Default	5	5 ms
	Level	ADVANCED	
	Address	654	
	Function	This parameter selects the value of the filter time constant of the first command applied to the REF input signal when the signal saturation and conversion is over.	

P055 Type of Signal over AIN1 Input

P055	Range	0 ÷ 4	0: ± 10 V 1: ± 20 mA 2: 4 ÷ 20 mA 3: 0 ÷ 10 V 4: 0 ÷ 20 mA
	Default	2	2: 4 ÷ 20 mA
	Level	ADVANCED	
	Address	655	
	Function	<p>This parameter selects the type of differential analog signal over terminals AIN1+ and AIN1- in the terminal board. The signal can be a voltage signal, a current signal, a unipolar signal, or a bipolar signal.</p> <p>0: ± 10 V Bipolar voltage input between -10V and +10V. The detected signal is saturated between these two values.</p> <p>1: ± 20 mA Bipolar current input between -20mA and +20mA. The detected signal is saturated between these two values.</p> <p>2: 4 ÷ 20 mA Unipolar current input with min. threshold, between +4 mA and +20mA. The detected signal is saturated between these two values. Before being saturated, if the detected signal is lower than 4 mA or greater than 20 mA, alarms A067 or A103 trip.</p> <p>3: 0 ÷ 10 V Unipolar voltage input between 0V and +10V. The detected signal is saturated between these two values.</p> <p>4: 0 ÷ 20 mA Unipolar current input between +0 mA and +20mA. The detected signal is saturated between these two values.</p>	



NOTE

The value set in parameter **P055** must match with the status of switch **SW1-2** allowing selecting the proper electric circuit for the analog signal processing (voltage signal or current signal).

P056 Value of AIN1 Input Producing Min. Reference (X-axis)

P056	Range	-100 ÷ 100, if P055 = 0 -200 ÷ 200, if P055 = 1 +40 ÷ 200, if P055 = 2 0 ÷ 100, if P055 = 3 0 ÷ 200, if P055 = 4	-10.0 V ÷ 10.0 V, if P055 = 0: ± 10 V -20.0 mA ÷ 20.0 mA, if P055 = 1: ± 20 mA +4.0mA ÷ 20.0 mA, if P055 = 2: 4 ÷ 20 mA 0.0 V ÷ 10.0V, if P055 = 3: 0 ÷ 10 V 0.0 mA ÷ 20.0 mA, if P055 = 4: 0 ÷ 20 mA
	Default	40	+4.0mA
	Level	ADVANCED	
	Address	656	
	Function	<p>This parameter selects the value for AIN1 input signal for minimum reference, or better the reference set in C028xP056a (Master mode) or in C047xP056a (Slave mode). If motor 2 is active, C071 and C090 will be used instead of C028 and C047; if motor 3 is active, the values set in C114 and C133 will be used.</p>	

P056a Percentage of Speed Min/Trq Min Producing Min. Reference (Y-axis related to P056)

P056a	Range	0 ÷ 1000	100.0%
	Default	1000	100.0%
	Level	ADVANCED	
	Address	677	
	Function	<p>This parameter represents the min. speed percentage (or the min. torque percentage for a torque reference) to be used for the minimum reference set with P056.</p>	

P057 Value of AIN1 Input Producing Max. Reference (X-axis)

P057	Range	-100 ÷ 100, if P055 = 0 -200 ÷ 200, if P055 = 1 +40 ÷ 200, if P055 = 2 0 ÷ 100, if P055 = 3 0 ÷ 200, if P055 = 4	-10.0 V ÷ 10.0 V, if P055 = 0: ± 10 V -20.0 mA ÷ 20.0 mA, if P055 = 1: ± 20 mA +4.0mA ÷ 20.0 mA, if P055 = 2: 4 ÷ 20 mA 0.0 V ÷ 10.0V, if P055 = 3: 0 ÷ 10 V 0.0 mA ÷ 20.0 mA, if P055 = 4: 0 ÷ 20 mA
	Default	200	+20.0mA
	Level	ADVANCED	
	Address	657	
	Function	This parameter selects the value for AIN1 input signal for maximum reference, or better the reference set in C029xP057a (Master mode) or in C048xP057a (Slave mode). If motor 2 is active, C072 and C091 will be used instead of C029 and C048 ; if motor 3 is active, the values set in C115 and C134 will be used.	

P057a Percentage of Speed Max/Trq Max Producing Max. Reference (Y-axis related to P057)

P057a	Range	0 ÷ 1000	100.0%
	Default	1000	100.0%
	Level	ADVANCED	
	Address	678	
	Function	This parameter represents the min. speed percentage (or the min. torque percentage for a torque reference) to be used for the minimum reference set with P057 .	

P058 Offset over AIN1 Input

P058	Range	-2000 ÷ 2000	-10.00 V ÷ +10.00 V, if P055 = 0 or 3 - 20.00 mA ÷ +20.00 mA, if P055 = 1,2,4
	Default	0	0 V
	Level	ADVANCED	
	Address	658	
	Function	This parameter selects the offset correction value of AIN1 analog signal that has been measured. The value set is added to the signal measured before saturation or conversion; its unit of measure is the same as the one of the signal selected for AIN1 analog input.	

P059 Filtering Time over AIN1 Input

P059	Range	0 ÷ +65000	0 ÷ +65000ms
	Default	5	5 ms
	Level	ADVANCED	
	Address	659	
	Function	This parameter selects the value of the filter time constant of the first command applied to AIN1 input signal when the signal saturation and conversion is over.	

P060 Type of Signal over AIN2 Input

P060	Range	0 ÷ 4	0: ± 10 V 1: ± 20 mA 2: 4 ÷ 20 mA 3: 0 ÷ 10 V 4: 0 ÷ 20 mA
	Default	2	2: 4 ÷ 20 mA
	Level	ADVANCED	
	Address	660	
	Function	<p>This parameter selects the type of differential analog signal over terminals AIN2+ and AIN2- in the terminal board. The signal can be a voltage signal, a current signal, a unipolar signal, or a bipolar signal.</p> <p>0: ± 10 V Bipolar voltage input between -10V and +10V. The detected signal is saturated between these two values.</p> <p>1: ± 20 mA Bipolar current input between -20mA and +20mA. The detected signal is saturated between these two values.</p> <p>2: 4 ÷ 20 mA Unipolar current input with min. threshold, between +4 mA and +20mA. The detected signal is saturated between these two values. Before being saturated, if the detected signal is lower than 4 mA or greater than 20 mA, alarms A068 or A104 trip.</p> <p>3: 0 ÷ 10 V Unipolar voltage input between 0V and +10V. The detected signal is saturated between these two values.</p> <p>4: 0 ÷ 20 mA Unipolar current input between +0 mA and +20mA. The detected signal is saturated between these two values.</p>	



NOTE

The value set in parameter **P060** must match with the status of switches **SW1-3**, **SW1-4** and **SW1-5** allowing selecting the proper electric circuit for the analog signal processing (voltage signal or current signal).



NOTE

If the PTC thermal protection (**C274**) is enabled, the reference from **AIN2** is automatically managed as a 0 ÷ 10V input. The only parameter enabled for the control of AIN2 is **P064**; **P060**, **P061**, **P061a**, **P062**, **P062a** and **P063** cannot be viewed and are not considered for calculations.

P061 Value of AIN2 Input Producing Min. Reference (X-axis)

P061	Range	-100 ÷ 100, if P060 = 0 -200 ÷ 200, if P060 = 1 +40 ÷ 200, if P060 = 2 0 ÷ 100, if P060 = 3 0 ÷ 200, if P060 = 4	-10.0 V ÷ 10.0 V, if P060 = 0: ± 10 V -20.0 mA ÷ 20.0 mA, if P060 = 1: ± 20 mA +4.0mA ÷ 20.0 mA, if P060 = 2: 4 ÷ 20 mA 0.0 V ÷ 10.0V, if P060 = 3: 0 ÷ 10 V 0.0 mA ÷ 20.0 mA , if P060 = 4: 0 ÷ 20 mA
	Default	40	4.0mA
	Level	ADVANCED	
	Address	661	
	Function	<p>This parameter selects the value for AIN2 input signal for minimum reference, or better the reference set in C028xP061a (Master mode) or in C047xP061a (Slave mode). If motor 2 is active, C071 and C090 will be used instead of C028 and C047; if motor 3 is active, the values set in C114 and C133 will be used.</p>	

P061a Percentage of Speed Min/Trq Min Producing Min. Reference (Y-axis related to P061)

P061a	Range	0 ÷ 1000	100.0%
	Default	1000	100.0%
	Level	ADVANCED	
	Address	679	
	Function	This parameter represents the min. speed percentage (or the min. torque percentage for a torque reference) to be used for the minimum reference set with P061 .	

P062 Value of AIN2 Input Producing Max. Reference (X-axis)

P062	Range	-100 ÷ 100, if P060 = 0 -200 ÷ 200, if P060 = 1 +40 ÷ 200, if P060 = 2 0 ÷ 100, if P060 = 3 0 ÷ 200, if P060 = 4	-10.0 V ÷ 10.0 V, if P060 = 0: ± 10 V -20.0 mA ÷ 20.0 mA, if P060 = 1: ± 20 mA +4.0mA ÷ 20.0 mA, if P060 = 2: 4 ÷ 20 mA 0.0 V ÷ 10.0V, if P060 = 3: 0 ÷ 10 V 0.0 mA ÷ 20.0 mA, if P060 = 4: 0 ÷ 20 mA
	Default	200	+20.0 mA
	Level	ADVANCED	
	Address	662	
	Function	This parameter selects the value for AIN2 input signal for maximum reference, or better the reference set in C029xP062a (Master mode) or in C048xP062a (Slave mode). If motor 2 is active, C072 and C091 will be used instead of C029 and C048 ; if motor 3 is active, the values set in C115 and C134 will be used.	

P062a Percentage of Speed Min/Trq Min Producing Max. Reference (Y-axis related to P062)

P062a	Range	0 ÷ 1000	100.0%
	Default	1000	100.0%
	Level	ADVANCED	
	Address	701	
	Function	This parameter represents the max. speed percentage (or the min. torque percentage for a torque reference) to be used for the maximum reference set with P062 .	

P063 Offset over AIN2 Input

P063	Range	-2000 ÷ 2000	-10.00 V ÷ +10.00 V, if P060 = 0 o 3 - 20.00 mA ÷ +20,00 mA , if P060 = 1,2,4
	Default	0	0 V
	Level	ADVANCED	
	Address	663	
	Function	This parameter selects the offset correction value of AIN2 analog signal that has been measured. The value set is added to the signal measured before saturation or conversion; its unit of measure is the same as the one of the signal selected for AIN2 analog input.	

P064 Filtering Time over AIN2 Input

P064	Range	0 ÷ +65000	0 ÷ +65000ms
	Default	5	5 ms
	Level	ADVANCED	
	Address	664	
	Function	This parameter selects the value of the filter time constant of the first command applied to AIN2 input signal when the signal saturation and conversion is over.	

P065 Minimum Reference and START Disabling Threshold

P065	Range	0 ÷ +32000	0 ÷ +32000 rpm
	Default	0	0rpm
	Level	ADVANCED	
	Address	665	
	Function	<p>If this parameter is other than zero, the current speed reference computed when processing of all active source references is over, it is saturated as an absolute value of this parameter's value. Saturation implies an absolute value, i.e. this parameter determines a "prohibit range" of the reference approx. zero. Example: P065 = 100 rpm and current speed reference is 500 rpm; if reference drops below 100 rpm, for example down to +50rpm, the value of the active reference is saturated to 100 rpm until reference exceeds 100 rpm again or is <u>lower than -100 rpm</u>; in that case, the preset value will be assigned to the reference. If also parameter P066 is other than zero, the drive disabling function is enabled: if the absolute value of the current speed reference is kept in the "prohibit range" <u>for a time longer than the time set in P066</u>, reference is set to zero and the motor speed decreases following the active ramp up to zero rpm; when the motor speed is equal to zero, the drive will automatically deactivate. With ENABLE-A and ENABLE-B inputs closed, the drive will automatically reactivate if the reference exceeds the value set in parameter P065 as an absolute value.</p>	



NOTE Parameter **P065** is active in Master mode only, i.e. when the reference is a direct speed reference not sent from PID with **C294** PID Action = 1:[Reference]).



NOTE Parameter **P065** is active only when the Speed searching and Power Down functions are disabled: **C245=0** and **C225=0**.

P066 START Disable delay at P065 Threshold

P066	Range	0 ÷ 250	0 ÷ 250 sec
	Default	0	0: Disabled
	Level	ADVANCED	
	Address	666	
	Function	<p>If this parameter is other than zero and if also parameter P065 is other than zero, the drive disabling function is enabled: if the absolute value of the current speed reference is kept in the "prohibit range" <u>for a time longer than the time set in P066</u>, reference is set to zero and the motor speed decreases following the active ramp up to zero rpm; when the motor speed is equal to zero, the drive will automatically deactivate. See also the description of parameter P065.</p>	

P067 Keypad and Terminal Board UP/DOWN Ramp

P067	Range	0 ÷ 6501	0 sec ÷ 6500s Quadratic
	Default	6501	Quadratic
	Level	ADVANCED	
	Address	667	
	Function	<p>Reference may be increased or decreased with input digital signals UP and DOWN, or using the ▲ and ▼ keys from the keypad (local mode). Reference increment or decrement is obtained by adding to the current reference a quantity which will be increased or decreased with a time ramp. Parameter P067 indicates the ramp time to increase the reference from zero to the preset speed (or torque) maximum absolute value, i.e. the max. value between absolute values Spd_Min and Spd_Max (or Trq_Min and Trq_Max). If motor 1 is active, Spd_Min=C028, Spd_Max=C029, Trq_Min=C047, Trq_Max=C048.</p>	

P068 Storage of UP/DOWN Values at Power Off

P068	Range	0 ÷ 1	0: Disabled, 1: Enabled
	Default	1	1: Enabled
	Level	ADVANCED	
	Address	668	
	Function	<p>If P068=1, the Speed/Torque or PID references added through input digital signals UP and DOWN or with the INC and DEC keys (local mode), are stored at the drive power off and are added to the start reference when the drive is restarted. This function allows storing the reference value obtained with UP and DOWN signals.</p>	

P068a Reset UP/DOWN Speed/Torque at Stop

P068a	Range	0 ÷ 1	0: NO, 1: YES
	Default	0	0: NO
	Level	ADVANCED	
	Address	940	
	Function	<p>If P068a =1: [Yes], the Speed/Torque reference sent via the UP/DOWN digital signals or with the ▲ and ▼ keys in the keypad is reset whenever the START command for the drive is disabled and the deceleration ramp is finished.</p>	

P068b Reset UP/DOWN PID at Stop

P068b	Range	0 ÷ 1	0: NO, 1: YES
	Default	0	0: NO
	Level	ADVANCED	
	Address	941	
	Function	<p>If P068b =1: [Yes], the PID reference sent via the UP/DOWN digital signals or via the ▲ and ▼ keys in the keypad) is reset whenever the START command for the drive is disabled and the deceleration ramp is finished.</p>	

P068c Reset UP/DOWN Speed/Torque at Source Changeover

P068c	Range	0 ÷ 1	0: NO, 1: YES
	Default	0	0: NO
	Level	ADVANCED	
	Address	942	
	Function	If P068c =1:[Yes], the Speed/Torque reference sent via the UP/DOWN digital signals or with the ▲ and ▼ keys in the keypad is reset whenever switching from the Remote mode to the Local mode and vice versa (using the LOC/REM key or the LOC/REM digital input, or when a command source switches to the other using the digital input programmed in C179 or C179a - MDI for source selection, see the DIGITAL INPUTS MENU).	

P068d Reset UP/DOWN PID at Source Changeover

P068d	Range	0 ÷ 1	0: NO, 1: YES
	Default	0	0: NO
	Level	ADVANCED	
	Address	943	
	Function	If P068d =1: [Yes], the PID reference sent via the UP/DOWN digital signals or with the ▲ and ▼ keys in the keypad is reset whenever switching from the Remote mode to the Local mode and vice versa (using the LOC/REM key or the LOC/REM digital input, or when a command source switches to the other using the digital input programmed in C179 - MDI for source selection, see the DIGITAL INPUTS MENU).	

P069 Range of UP/DOWN Reference

P069	Range	0 ÷ 1	0: Bipolar, 1: Unipolar
	Default	1	1: Unipolar
	Level	ADVANCED	
	Address	669	
	Function	If P069 =1, the quantity added via the UP/DOWN digital signals or with the ▲ and ▼ keys (Local mode) is unipolar, i.e. it is positive only and has a min. value equal to zero. For bipolar quantities, the added quantity may be negative.	

P070 JOG reference (Speed/Torque)

P070	Range	± 100	± 100 %
	Default	0	0 %
	Level	ADVANCED	
	Address	670	
	Function	Value of the JOG reference. For speed control, the percentage of the jog reference relates to the maximum speed value of the selected motor (max. value as an absolute value between min. and max. speed parameters); in case of torque control, the percentage of the jog reference relates to the max. torque value of the selected motor (max. value as an absolute value between min. and max. torque limit).	

P071 Value of FIN Producing Min. Reference (X-axis)

P071	Range	1000 ÷ 10000	10 kHz ÷ 100 kHz
	Default	1000	10 kHz
	Level	ADVANCED	
	Address	671	
	Function	This parameter selects the value of the frequency input signal for minimum reference, or better the reference set in C028xP071a (Master mode) or in C047xP071a (Slave mode). If motor 2 is active, C071 and C090 will be used instead of C028 and C047 ; if motor 3 is active, the values set in C114 and C133 will be used.	

P071a Percentage of Speed Min/Trq Min Producing Min. Reference (Y-axis related to P071)

P071a	Range	0 ÷ 1000	100.0%
	Default	1000	100.0%
	Level	ADVANCED	
	Address	713	
	Function	This parameter represents the min. speed percentage (or the min. torque percentage for a torque reference) to be used for the minimum reference set with P071 .	

P072 Value of FIN Producing Max. Reference (X-axis)

P072	Range	1000 ÷ 10000	10 kHz ÷ 100 kHz
	Default	10000	100 kHz
	Level	ADVANCED	
	Address	672	
	Function	This parameter selects the value of the frequency input signal for maximum reference, or better the reference set in C029xP072a (Master mode) or in C048xP072a (Slave mode). If motor 2 is active, C072 and C091 will be used instead of C029 and C048 ; if motor 3 is active, the values set in C115 and C134 will be used.	

P072a Percentage of Speed Max/Trq Max Producing Max. Reference (Y-axis related to P072)

P072a	Range	0 ÷ 1000	100.0%
	Default	1000	100.0%
	Level	ADVANCED	
	Address	714	
	Function	This parameter represents the max. speed percentage (or the max. torque percentage for a torque reference) to be used for the maximum reference set with P072 .	

P073 Value of ECH Producing Min. Reference (X-axis)

P073	Range	-32000 ÷ 32000	± 32000 rpm
	Default	0	0 rpm
	Level	ADVANCED	
	Address	673	
	Function	This parameter selects the value of the Encoder input for minimum reference, or better the reference set in C028xP073a (Master mode) or in C047xP073a (Slave mode). If motor 2 is active, the values set in C071 and C090 will be used instead of C028 and C047 ; if motor 3 is active, the values set in C114 and C133 will be used.	

P073a Percentage of Speed Min/Trq Min Producing Min. Reference (Y-axis related to P073)

P073a	Range	0 ÷ 1000	100.0%
	Default	1000	100.0%
	Level	ADVANCED	
	Address	702	
	Function	This parameter represents the max. speed percentage (or the min. torque percentage for a torque reference) to be used for the maximum reference set with P073 .	

P074 Value of ECH Producing Max. Reference (X-axis)

P074	Range	-32000 ÷ 32000	± 32000 rpm
	Default	+1500	+1500 rpm
	Level	ADVANCED	
	Address	674	
	Function	This parameter selects the value of the Encoder input for maximum reference, or better the reference set in C029xP074a (Master mode) or in C048xP074a (Slave mode). If motor 2 is active, C072 and C091 will be used instead of C029 and C048 ; if motor 3 is active, the values set in C115 and C134 will be used.	

P074a Percentage of Speed Max/Trq Max Producing Max. Reference (Y-axis related to P074)

P074a	Range	0 ÷ 1000	100.0%
	Default	1000	100.0%
	Level	ADVANCED	
	Address	703	
	Function	This parameter represents the max. speed percentage (or the max. torque percentage for a torque reference) to be used for the maximum reference set with P074 .	

14. MULTISPEED MENU

14.1. Overview



NOTE See also the INPUTS FOR REFERENCES MENU and the DIGITAL INPUTS MENU.

The Multispeed menu allows defining the values for 15 **preset speed** (or **multispeed**) references set in parameters **P081** to **P098**. Their application method is set in **P080**.

The desired speed is selected through the digital inputs described in the previous section, relating to the **Digital Inputs Menu**.

The following reference ranges that can be programmed with the parameters above:

- ± 32000 rpm if multispeed unit of measure is → **P100** = 1.00 rpm
- ± 3200.0 rpm if multispeed unit of measure is → **P100** = 0.10 rpm
- ± 320.00 rpm if multispeed unit of measure is → **P100** = 0.01 rpm

Use parameters **C155**, **C156**, **C157** and **C158** to set the digital inputs in multispeed mode.

Parameter **P080** defines the functionality of the references set in the preset speed function: PRESET SPEED, SUM SPEED, EXCLUSIVE PRESET SPEED.

If **P080** = **PRESET SPEED**, the speed reference is the value set in the preset speed which is active at that moment. If digital inputs set as **multispeed** are all open (inactive), the speed reference is the reference coming from the sources selected in the **Control Method Menu (C143 to C146)**.

If **P080** = **EXCLUSIVE PRESET SPEED**, the speed reference is the value set in the multispeed which is active at that moment. If digital inputs set as **multispeed** are all open (inactive), no other reference source is considered; the speed reference is zero.

If **P080** = **SUM SPEED**, the speed reference value assigned to the **preset speed** which is active at that moment is summed up to the total amount of the speed references.

The reference obtained is always saturated by the parameters relating to the min. speed and the max. speed of the selected motor.

14.2. List of Parameters P080 to P100

Table 28: List of Parameters P080 to P100

Parameter	FUNCTION	User Level	DEFAULT VALUES	MODBUS Address
P080	Multispeed function	BASIC	0:Preset Speed	680
P081	Output speed Mspd1	BASIC	0.00 rpm	681
P083	Output speed Mspd2	BASIC	0.00 rpm	683
P085	Output speed Mspd3	BASIC	0.00 rpm	685
P087	Output speed Mspd4	ADVANCED	0.00 rpm	687
P088	Output speed Mspd5	ADVANCED	0.00 rpm	688
P089	Output speed Mspd6	ADVANCED	0.00 rpm	689
P090	Output speed Mspd7	ADVANCED	0.00 rpm	690
P091	Output speed Mspd8	ADVANCED	0.00 rpm	691
P092	Output speed Mspd9	ADVANCED	0.00 rpm	692
P093	Output speed Mspd10	ADVANCED	0.00 rpm	693
P094	Output speed Mspd 11	ADVANCED	0.00 rpm	694
P095	Output speed Mspd 12	ADVANCED	0.00 rpm	695
P096	Output speed Mspd 13	ADVANCED	0.00 rpm	696
P097	Output speed Mspd 14	ADVANCED	0.00 rpm	697
P098	Output speed Mspd 15	ADVANCED	0.00 rpm	698
P099	Fire Mode speed	ENGINEERING	750 rpm	699
P100	Multispeed unit of measure	ADVANCED	2: 1.0 rpm	700

P080 Multispeed Function

P080	Range	0 ÷ 2	0: Preset Speed, 1: Sum Speed, 2: Exclusive Preset Speed
	Default	0	0: Preset Speed
	Level	BASIC	
	Address	680	
	Function	<p>Defines the functionality of the multispeed values for the global speed reference. Three functions are available:</p> <ul style="list-style-type: none"> • 0: [Preset Speed] → the selected multispeed is the actual rpm value (upon limit due to min. and max. speed parameters for the selected motor) of the motor speed reference. If no multispeed is selected (<i>no digital input programmed for multispeed selection is activated, or all digital inputs programmed for multispeed selection are deactivated</i>), the speed reference is the reference for the sources set in the CONTROL METHOD MENU. • 1: [Sum Speed] → the reference relating to the selected multispeed is considered as the sum of the references for the other reference sources selected in the CONTROL METHOD MENU. • 2: [Exclusive Preset Speed] → the selected multispeed is the actual rpm value (upon saturation due to min. and max. speed parameters for the selected motor) of the motor speed reference. Unlike function 0 [Preset Speed], if no multispeed is selected (<i>no digital input programmed for multispeed selection is activated, or all digital inputs programmed for multispeed selection are deactivated</i>) the speed reference is zero. 	

P081 to P098 Output Speed Mspd n.1 (/15)

P081÷P098	Range	-32000 ÷ 32000	±32000 rpm
	Default	0	0.00 rpm
	Level	From P081 to P085 : BASIC From P087 to P098 : ADVANCED	
	Address	681÷698	
	Function	<p>This parameter sets the multispeed output speed selected through the relevant digital inputs (Table 101). The multispeed value is scaled based on the unit of measure set in P100.</p> <p>The reference resulting from the multispeed selected through the relevant digital inputs will be computed based on the setting of parameter P080.</p>	

P099 Fire Mode Speed

P099	Range	-32000 ÷ 32000	±32000 rpm
	Default	750	750.00 rpm
	Level	ENGINEERING	
	Address	699	
	Function	Determines the value of the output speed in Fire Mode. The Fire Mode speed depends on the unit of measure programmed in P100 .	

P100 Multispeed Unit of Measure

P100	Range	0 ÷ 2	0: [0.01 rpm] ÷ 2: [1.0 rpm]
	Default	2	2: [1.0 rpm]
	Level	ADVANCED	
	Address	700	
	Function	Determines the unit of measure considered for the 15 allowable multispeed values and the Fire Mode speed in P099 .	



CAUTION

When changing the unit of measure of the multispeed values in **P100**, the preset speed values for the multispeed and Fire Mode values will be RECOMPUTED.

15. PID MULTIREFERENCES MENU

15.1. Overview

This menu includes the parameters for the utilisation and allocation of PID Multireferences from digital inputs. The reference sources are based on the setup in parameters **C285** to **C287** (see the PID CONFIGURATION MENU). The overall reference also depends on the multireferences that are already set (if any) or on the reduction percent of the reference itself (see the REFERENCE VARIATION PERCENT MENU).

Configuration example:

PID Configuration Menu

C285 Source of PID reference 1 = 2: AIN1
C286 Source of PID reference 2 = 0: Disable
C287 Source of PID reference 3 = 0: Disable

Digital Inputs Menu

C188a Input for PID Multireference 1 = 7: MDI7
C188b Input for PID Multireference 2 = 8: MDI8
C188c Input for PID Multireference 3 = 0: Disable

PID Multireferences Menu

P081a PID Reference 1 (Mref 1) = 1.0 bars
P082a PID Reference 2 (Mref 2) = 1.5 bars
P083a PID Reference 3 (Mref 3) = 2.5 bars

PID Parameters Menu

P257 Gain for PID scaling = 0.1

When AIN1 analog input is set to 100%, the pressure reference is 10 bars
 (100%***P257** =10.0).

Supposing that AIN1 is set to 43%, the references below are obtained based on the combination of the digital inputs configured as multireferences, and based on the function allocated to parameter **P080a**.

P080a = 0: Preset Ref. If both digital inputs configured as Multireferences are not activated, the overall reference is given from AIN1 analog input selected as the first PID reference (**C285**):

P080a Multireference Function = Preset Ref.		
MDI8	MDI7	Overall reference
0	0	4.3 bars
0	1	1.0 bars
1	0	1.5 bars
1	1	2.5 bars

P80a = 1: Sum Ref. If both digital inputs configured as Multireference are inactive, the overall reference is given from AIN1 analog input selected as the first PID reference (**C285**). For the combinations where at least one of the digital inputs configured as multireference is active, the resulting reference is the sum of the value for AIN1 plus the value for the selected multireference.

P080a Multireference Function = Exclusive Preset Ref.		
MDI8	MDI7	Overall reference
0	0	4.3 bars
0	1	5.3 bars
1	0	5.8 bars

**SINUS PENTA
PENTA MARINE**



PROGRAMMING GUIDE

1	1	6.8 bars
---	---	----------

P80a= 2: Exclusive Preset Ref. If no Multireference is activated, the overall reference is null.

P080a Multireference Function = 2: Exclusive Preset Ref.		
MDI8	MDI7	Overall Reference
0	0	0.0 bars
0	1	1.0 bars
1	0	1.5 bars
1	1	2.5 bars

15.2. List of Parameters P080a to P099a

Table 29: List of Parameters P080a to P099a

Parameter	FUNCTION	User Level	DEFAULT VALUE	MODBUS Address
P080a	PID Multireference function	ENGINEERING	0	944
P081a	PID Multireference 1 (Mref1)	ENGINEERING	0	945
P082a	PID Multireference 2 (Mref2)	ENGINEERING	0	946
P083a	PID Multireference 3 (Mref3)	ENGINEERING	0	947
P084a	PID Multireference 4 (Mref4)	ENGINEERING	0	948
P085a	PID Multireference 5 (Mref5)	ENGINEERING	0	949
P086a	PID Multireference 6 (Mref6)	ENGINEERING	0	986
P087a	PID Multireference 7 (Mref7)	ENGINEERING	0	987
P099a	PID Reference in Fire Mode	ENGINEERING	50%	988

P080a Multireference

P080a	Range	0 ÷ 2	0: Preset Ref 1: Sum Ref 2: Exclusive Preset Ref.
	Default	0	0: [Preset Ref]
	Level	ENGINEERING	
	Address	944	
	Function	This parameter sets if the PID reference resulting from the selection of a digital multireference is to be considered either as the unique active reference or as summed up to the other configured PID reference sources (see example above).	

P081a÷P087a PID Multireference 1÷7

P081a÷P087a	Range	-1000 ÷ +1000	±1000
	Default	0	0
	Level	ENGINEERING	
	Address	945÷949, 986÷987	
	Function	<p>This is the value of the PID reference selected with the corresponding combination of the digital inputs programmed as multireferences.</p> <p>The reference is expressed in the unit of measure set with P267 (see the DISPLAY/KEYPAD MENU) and is based on parameter P257 (Gain for PID Scaling).</p> <p>Example: The max. value for the PID feedback is 100%. This value corresponds to a level of 25m in a tank.</p> <p>When P257 = 0.25, 100% of PID feedback corresponds to 25 metres. When setting a reference level of 15 meters, multireference 1 shall be set as P081a = 15.0 m.</p>	

P099a PID Reference in Fire Mode

P099a	Range	-1000 ÷ 1000	±1000
	Default	500	50.0 %
	Level	ENGINEERING	
	Address	988	
	Function	This parameter sets the value of the PID reference when in Fire Mode. The value of the PID reference depends on the scale factor set in P257 .	

16. MULTITORQUE MENU

16.1. Overview



NOTE The Multitorque mode described in this section is active for the **VTC** and **FOC** controls only.



NOTE Please refer to the DIGITAL INPUTS MENU in this Programming Guide.

Maximum 3 torque **limit** values may be set up via parameters **P101** to **P103**.

The torque limits may be selected via the 2 digital inputs set via parameters **C187a**, **C187b** (see DIGITAL INPUTS MENU).

If these inputs are both inactive, the Multitorque functionality is disabled and the torque limit is selected as follows:

- From the limit source (if any) set in **C147**;
- From the values set in **C047**, **C048** (see LIMITS MENU).

The torque limits in the Multitorque Menu are saturated by the minimum and maximum torque limits (**C047**, **C048** for motor 1) and are disabled by the input programmed in **C187** (Limit Source Disable).

The Multitorque limit values are expressed as a percentage of the rated torque and are automatically limited within the range set by the minimum and maximum torque limits (**C047**, **C048** for motor 1).

16.2. List of Parameters P101 to P103

Table 30: List of Parameters P101 to P103

Parameter	FUNCTION	User Level	DEFAULT VALUE	MODBUS Address
P101	Torque Limit 1	ADVANCED	0.0%	637
P102	Torque Limit 2	ADVANCED	0.0%	638
P103	Torque Limit 3	ADVANCED	0.0%	639

P101 to P103 Torque Limit 1 (2, 3)

P080a	Range	-5000 ÷ 5000	±500.0%
	Default	0	0.0%
	Level	ADVANCED	
	Address	637, 638, 639	
	Control	VTC and FOC	
	Function	These parameters set a forced torque limit. The active limit value depends on the status of the digital inputs set in C187a ÷ C187b .	

17. PROHIBIT SPEED MENU

17.1. Overview

This menu allows setting prohibit speed ranges that the motor cannot maintain at constant rpm due to mechanical resonance.

Three prohibit speed ranges are available: 3 intermediate values of the speed range and their semi-amplitude (one for all ranges).

In this way, the speed reference value is never included in one of the preset speed ranges; when decreasing, if the speed reference matches with the max. allowable value of a prohibit speed range, the value assigned to the reference is given by the min. allowable value of the speed range, and vice versa when the reference is increasing.

The discontinuity of the speed reference has no effect on the actual speed of the connected motor, because this will vary with continuity until it reaches the new rpm value of the speed reference.

The intermediate values of the prohibit speed ranges are to be intended as absolute values (independent of the reference sign, +/-).

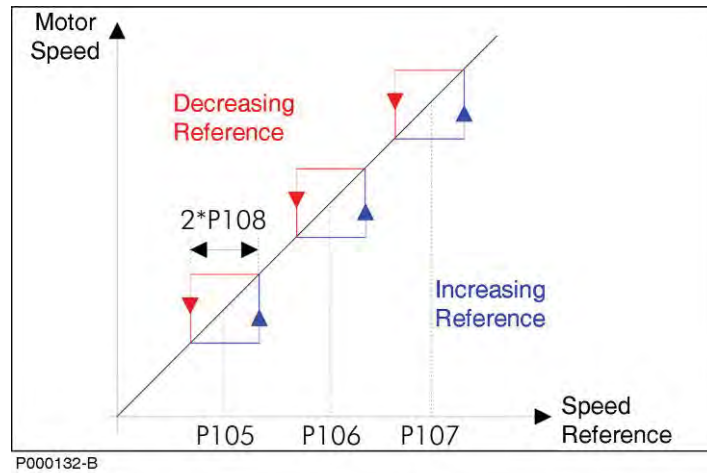

Figure 12: Prohibit Speed ranges

Figure 12 illustrates different trends of the speed reference when it matches with the max. allowable value of a prohibit speed range when decreasing (red) or when it matches with the min. allowable value of a prohibit speed range when increasing (blue).

Example:

P105 = 500 rpm Prohibit speed 1

P106 = 650 rpm Prohibit speed 2

P107 = 700 rpm Prohibit speed 3

P108 = 50 rpm Semi-amplitude of prohibit speed ranges

Range Number	Min. Allowable Value	Max. Allowable Value
1	450 rpm	550 rpm
2	600 rpm	700 rpm
3	650 rpm	750 rpm

In this case, the second and third prohibit ranges partially match, because the max. allowable value of the second range (700 rpm) is higher than the min. allowable value of the third range (650 rpm), thus forming a prohibit speed range ranging from 600 rpm to 750 rpm.

17.2. List of Parameters P105 to P108

Table 31: List of Parameters P105 to P108

Parameter	FUNCTION	User Level	MODBUS Address
P105	Prohibit speed 1	ADVANCED	705
P106	Prohibit speed 2	ADVANCED	706
P107	Prohibit speed 3	ADVANCED	707
P108	Hysteresis (band) of prohibit speed ranges	ADVANCED	708

P105 (P106, P107) Prohibit Speed 1 (2, 3)

P105	Range	0 ÷ 32000	0 ÷ 32000 rpm
	Default	0	0 rpm
	Level	ADVANCED	
	Address	705 706 707	
	Function	Determines the intermediate value of the first prohibit speed range. This value is to be considered as an absolute value, i.e. independent of the speed reference sign (+/-).	

P108 Hysteresis (band) of Prohibit Speed Ranges

P108	Range	0 ÷ 5000	0 ÷ 5000 rpm
	Default	0	0 rpm
	Level	ADVANCED	
	Address	708	
	Function	Sets the semi-amplitude of the prohibit speed ranges.	

18. REFERENCE VARIATION PERCENT MENU

18.1. Overview

The Reference Variation Percent Menu allows defining the variation values of the speed/torque or PID instant reference to be entered through digital inputs that have been properly programmed.

As per the selection of the variation percentage programmed to the reference and given by the combination of digital inputs configured with parameters **C175 ÷ C177**, please refer to the DIGITAL INPUTS MENU.

The parameters included in this menu represent seven speed/torque or PID variation options to be applied to the speed reference.

Variation may range from **-100.0% to 100.0%** of the instant reference given by the addition of all the selected sources.

Example:

P115=	0.0%	Variation percent of reference 1
P116=	50.0%	Variation percent of reference 2
P117=	-80.0%	Variation percent of reference 3

Based on the speed/torque or PID variation selected through digital inputs, the speed reference at constant speed will be as follows:

Variation 1: the current reference with no changes (no effect).

Variation 2: the current reference increased by 50.0%.

Variation 3: the current reference decreased by 80.0%.



NOTE

Whatever the speed/torque reference value resulting from the application of a speed variation, the value used to control the motor is saturated at max. and min. speed/torque values set in the parameters relating to the selected motor.

Speed control (example):

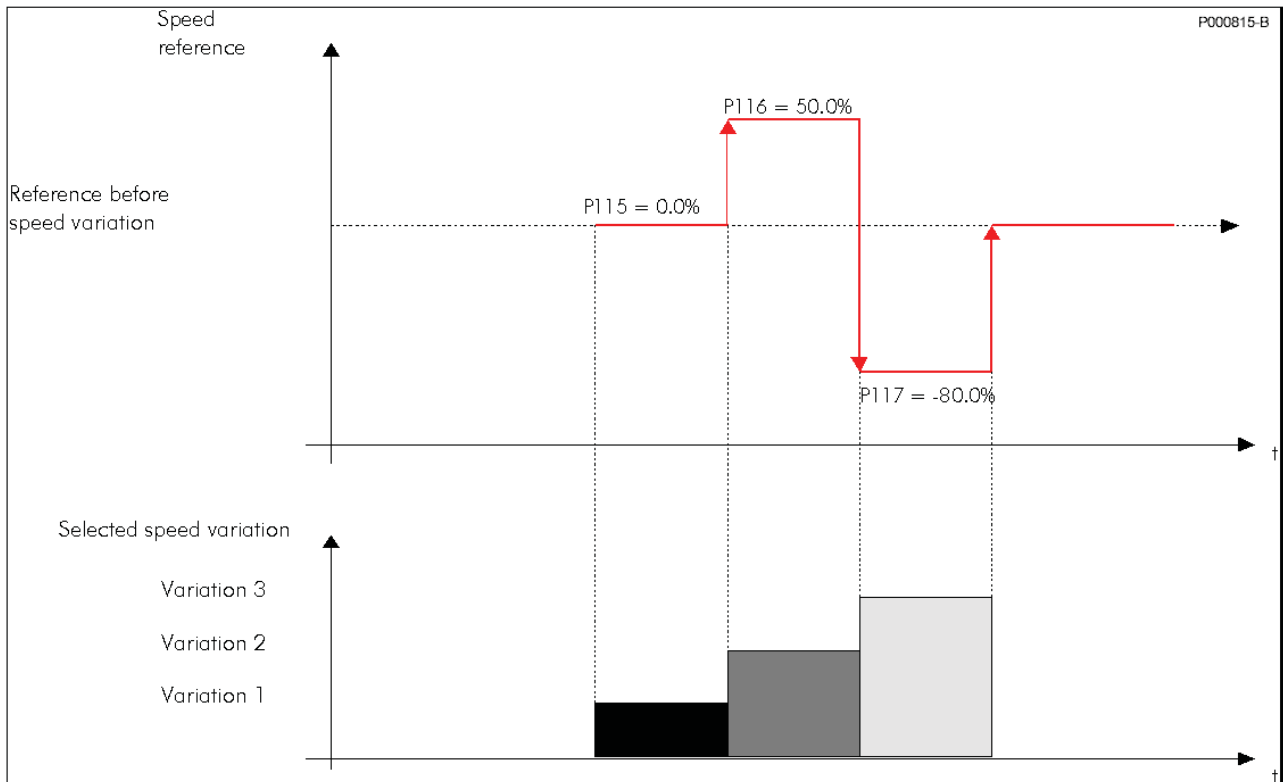

18.2. List of Parameters P115 to P121

Table 32: List of Parameters P115 to P121

Parameter	FUNCTION	User Level	Default Values	MODBUS Address
P115	Reference variation percent n.1	ENGINEERING	0.0%	715
P116	Reference variation percent n.2	ENGINEERING	0.0%	716
P117	Reference variation percent n.3	ENGINEERING	0.0%	717
P118	Reference variation percent n.4	ENGINEERING	0.0%	718
P119	Reference variation percent n.5	ENGINEERING	0.0%	719
P120	Reference variation percent n.6	ENGINEERING	0.0%	720
P121	Reference variation percent n.7	ENGINEERING	0.0%	721

P115 (+ P121) Reference Variation Percent n.1 (+n.7)

P115 (+ P121)	Range	±1000	±100.0%
	Default	0	0.0%
	Level	ENGINEERING	
	Address	715 (+721)	
	Function	These parameters define the variation percent of the current reference (M000 for speed control, M007 for torque control, M018 if PID control is activated) to be considered as a ramp reference when selecting variation percent 1 (+7).	

19. SPEED LOOP AND CURRENT BALANCING MENU

19.1. Overview

The SPEED LOOP AND CURRENT BALANCING MENU, for VTC and FOC controls, allows setting the parameter values of the speed regulators for the three connected motors and to manually adjust the motor current balancing (see parameter **P152**).

The speed regulator for each motor has two parameterization functions: two integral terms and two proportional terms.

As per factory settings, only parameters **P126** (Maximum Integral Time) and **P128** (Minimum Integral Time) are used.

Adopting the remaining two parameters **P125** (Minimum Integral Time) and **P129** (Maximum Proportional Constant) is based on two possible control logics:

- Status of the digital input set in **C169a** (FOC control only);
- Logics based on the adjustment error.

Status of the digital input set in **C169a**: if the input is low, parameters **P126/P128** will be active; otherwise (high logic level) parameters **P125/P129** will be active.

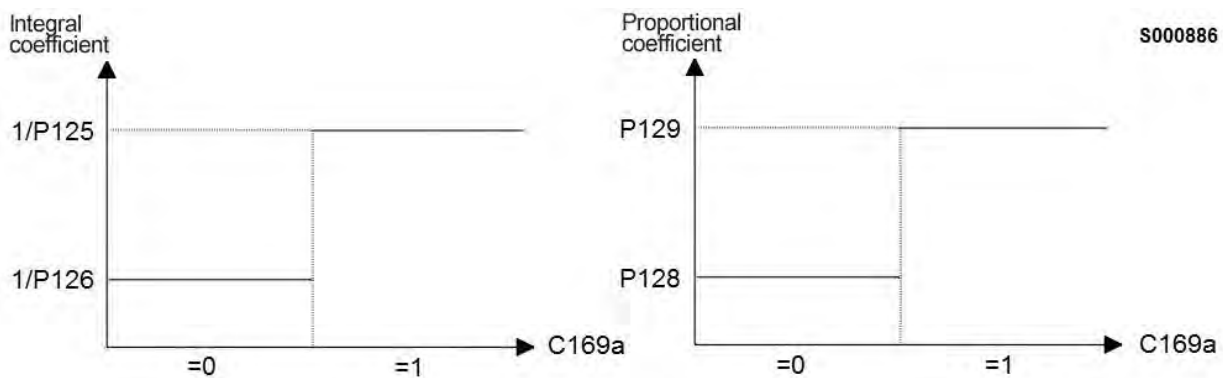

Figure 14: Example of dual parameterization activated by a digital input

Logic based on adjustment error: This second logic enables a regulator's response dynamically related to the speed error; in that way, the speed regulator will be more reactive to big errors and less sensitive to small errors. To activate this control logics, speed error thresholds **P130** and **P131** (expressed as a percentage of the rated speed) are to be set to different values.

The response of the speed regulator can be dynamically linked with the speed error; in this way, the speed regulator will be more sensitive to remarkable speed errors and less sensitive to negligible speed errors.

Factory setting: because two identical error thresholds are set, only two parameters are used: **P126** (maximum integral time) and **P128** (minimum proportional constant).

The setup of min. integral time and max. proportional constant is enabled provided that two different error thresholds are used.

Example:

P125	100	[ms]	Minimum integral time
P126	500	[ms]	Maximum integral time
P128	10.00		Minimum proportional constant
P129	25.00		Maximum proportional constant
P130	2	[%]	Minimum error threshold
P131	20	[%]	Maximum error threshold

Error ≤ **P130**

For speed errors lower than or equal to 2% of the motor rated speed, the speed regulator adopts parameters **P126** and **P128**.

Error ≥ P131

If the speed error is higher than or equal to 20% of the rated motor speed, the speed regulator adopts parameters **P125** and **P129**.

P130 < Error < P131

When the speed error is included between the two error thresholds, the speed regulator will use coefficients that are dynamically linked with the speed error (see figure below).

$$\begin{aligned} \text{Integral coefficient} &= (1/P126) + [(err\% - P130) * (1/P125 - 1/P126) / (P131 - P130)] \\ \text{Proportional coefficient} &= P128 + [(err\% - P130) * (P129 - P128) / (P131 - P130)] \end{aligned}$$

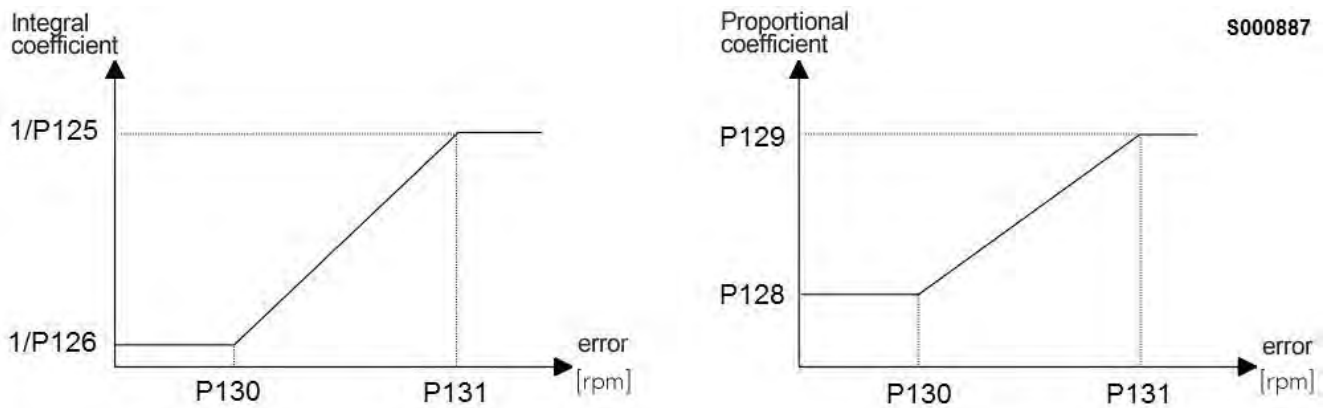

Figure 15: Error threshold Dual Parameterization function (example)

19.2. List of Parameters P125 to P153

Table 33: List of Parameters P125 to P153

Parameter	FUNCTION	User Level	Default Values	MODBUS Address
P125	Mot1 Minimum integral time	BASIC	500 ms	725
P126	Mot1 Maximum integral time	BASIC	500 ms	726
P128	Mot1 Minimum proportional coefficient	BASIC	10.00	728
P129	Mot1 Maximum proportional coefficient	BASIC	10.00	729
P130	Mot1 Minimum error threshold	BASIC	1.00%	730
P131	Mot1 Maximum error threshold	BASIC	1.00%	731
P135	Mot2 Minimum integral time	BASIC	500 ms	735
P136	Mot2 Maximum integral time	BASIC	500 ms	736
P138	Mot2 Minimum proportional coefficient	BASIC	10.00	738
P139	Mot2 Maximum proportional coefficient	BASIC	10.00	739
P140	Mot2 Minimum error threshold	BASIC	1.00%	740
P141	Mot2 Maximum error threshold	BASIC	1.00%	741
P145	Mot3 Minimum integral time	BASIC	500 ms	745
P146	Mot3 Maximum integral time	BASIC	500 ms	746
P148	Mot3 Minimum proportional coefficient	BASIC	10.00	748
P149	Mot3 Maximum proportional coefficient	BASIC	10.00	749
P150	Mot3 Minimum error threshold	BASIC	1.00%	750
P151	Mot3 Maximum error threshold	BASIC	1.00%	751
P152	Symmetry regulation of three-phase current	ENGINEERING	0%	752
P153	VTC speed error filter time constant	ENGINEERING	10 ms	753

P125 (P135, P145) Minimum Integral Time

P125 (Motor n.1) P135 (Motor n.2) P145 (Motor n.3)	Range	1÷ 32000	0.001÷ 32.000 [Disable] ms
	Default	500	500 ms
	Level	BASIC	
	Address	725, 735, 745	
	Control	VTC and FOC	
	Function	This parameter sets the min. integral time for the speed regulator. It may be accessed if the min. and max. error thresholds are different (P130≠P131 for Motor1, P140≠P141 for Motor2, P150≠P151 for Motor3), or if the switch digital input C169a (FOC mode only) is activated.	

P126 (P136, P146) Maximum Integral Time

P126 (Motor n.1) P136 (Motor n.2) P146 (Motor n.3)	Range	1÷ 32000	0.001÷ 32.000 [Disable] ms
	Default	500	500 ms
	Level	BASIC	
	Address	726, 736, 746	
	Control	VTC and FOC	
	Function	This parameter sets the max. integral time for the speed regulator. If the min. and max. error thresholds are set the same values (P130=P131 for Mot1, P140=P141 for Mot2, P150=P151 for Mot3), or the switch digital input set to C169a (FOC only) has a low logic value, this parameter is the integral time of the speed regulator.	

**SINUS PENTA
PENTA MARINE**



PROGRAMMING GUIDE

P128 (P138, P148) Minimum Proportional Coefficient

P128 (Motor n.1) P138 (Motor n.2) P148 (Motor n.3)	Range	0 ÷ 65000	0.00 ÷ 650.00
	Default	1000	10.00
	Level	BASIC	
	Address	728,738,748	
	Control	VTC and FOC	
Function	This parameter sets the min. proportional coefficient for the speed regulator. If the minimum and maximum error thresholds are set the same value (P130=P131 for Mot1, P140=P141 for Mot2, P150=P151 for Mot3), or the switch digital input set in C169a (FOC mode only) has a low logic value, this parameter represents the proportional coefficient of the speed regulator. Default value (10): if a speed error of 1% occurs, the regulator will require 10% of the rated motor torque.		

P129 (P139, P149) Maximum Proportional Coefficient

P129 (Motor n.1) P139 (Motor n.2) P149 (Motor n.3)	Range	0 ÷ 65000	0.00 ÷ 650.00
	Default	1000	10.00
	Level	BASIC	
	Address	729,739,749	
	Control	VTC and FOC	
Function	This parameter sets the max. proportional coefficient for the speed regulator. Default value (10): if a speed error of 1% occurs, the regulator will require 10% of the rated motor torque. This parameter may be accessed if the min. and max. error thresholds are different (P130 ≠ P131 for Motor1, P140 ≠ P141 for Motor2, P150 ≠ P151 for Motor3), or if the switch digital input C169a (FOC mode only) is activated.		

P130 (P140, P150) Min. Error Threshold

P130 (Motor n.1) P140 (Motor n.2) P150 (Motor n.3)	Range	0 ÷ 32000	0.00 ÷ 320.00
	Default	100	1.00%
	Level	BASIC	
	Address	730,740,750	
	Control	VTC and FOC	
Function	This parameter determines the min. error threshold expressed as a percentage of the rated motor speed. When the switch logics based on C169a is disabled, if the speed error is lower than or equal to the min. threshold, parameters P126 and P128 will be used.		

P131 (P141, P151) Max. Error Threshold

P131 (Motor n.1) P141 (Motor n.2) P151 (Motor n.3)	Range	0 ÷ 32000	0.00 ÷ 320.00
	Default	100	1.00%
	Level	BASIC	
	Address	731,741,751	
	Control	VTC and FOC	
	Function	This parameter sets the max. error threshold expressed as a percentage of the rated motor speed. When the switch logics based on C169a is disabled, if the speed error is lower than or equal to the max. threshold, parameters P125 and P129 will be used.	

P152 Symmetry Regulation of Three-phase Current

P152	Range	± 100	± 100%
	Default	0	0%
	Level	ENGINEERING	
	Address	752	
	Function	This parameter affects three-phase current balancing. It must be used when dissymmetry of the motor currents occurs, especially when no-load currents are delivered and the motor rotates at low rpm.	

P153 VTC Speed Error Filter Time Constant

P153	Range	0 ÷ 32000	0 ÷ 32000 ms
	Default	10	10 ms
	Level	ENGINEERING	
	Address	753	
	Control	VTC	
	Function	Input speed error filter time constant, in speed loop of VTC control.	

20. FOC REGULATORS MENU

20.1. Overview



NOTE Please refer to the MOTOR CONFIGURATION MENU as well.



NOTE This menu may be accessed only if the FOC control is programmed for one of the connected motors (**C010=2** for motor n.1, **C053=2** for motor n.2, **C096=2** for motor n.3).

The FOC control has the same basic structure as that of any classic field oriented control. The inner loops of FOC control are **two PI current regulators** having the same parameterization. The first regulator controls **Iq torque current**; the second regulator controls **Id flux current**.

Iq Torque current is computed based on the required torque set-point.

In **Slave mode** (torque reference), the required set-point comes from the external reference; in **Master mode**, the torque set-point is given by the output of the **speed regulator** (see the SPEED LOOP AND CURRENT BALANCING MENU) for the regulation of the motor speed of rotation.

Id Flux current results from the output of the **flux regulator**, ensuring that the connected motor is always properly fluxed.

This menu allows accessing the current PI regulators and flux regulators for the FOC control.

20.2. List of Parameters P155 to P173

Table 34: List of Parameters P155 to P173

Parameter	FUNCTION	User Level	Default Values	MODBUS Address
P155	Current regulator proportional constant, Mot n.1	ENGINEERING	3.00	755
P156	Current regulator integral time, Mot n.1	ENGINEERING	20.0 ms	756
P158	Flux regulator proportional constant, Mot n.1	ENGINEERING	0.00	758
P159	Flux regulator integral time, Mot n.1	ENGINEERING	33 ms	759
P162	Current regulator proportional constant, Mot n.2	ENGINEERING	3.00	762
P163	Current regulator integral time, Mot n.2	ENGINEERING	20.0 ms	763
P165	Flux regulator proportional constant, Mot n.2	ENGINEERING	0.00	765
P166	Flux regulator integral time, Mot n.2	ENGINEERING	33 ms	766
P169	Current regulator proportional constant, Mot n.3	ENGINEERING	3.00	769
P170	Current regulator integral time, Mot n.3	ENGINEERING	20.0 ms	770
P172	Flux regulator proportional constant, Mot n.3	ENGINEERING	0.00	772
P173	Flux regulator integral time, Mot n.3	ENGINEERING	33 ms	773

P155 (P162, P169) Current Regulator Proportional Constant

P155 (Motor n.1) P162 (Motor n.2) P169 (Motor n.3)	Range	0 ÷ 65000	0.00 ÷ 650.00
	Default	300	3.00
	Level	ENGINEERING	
	Address	755 762 769	
	Control	FOC	
	Function	<p>Kp Proportional coefficient of PI current regulator Id and Iq in field rotary reference for motor n.1 (P162 and P169 relate to motors 2 and 3). The regulator's structure is as follows: error = Set_Point – Measure; integral_status = integral_status + error *Ki*Ts; Output = Kp*error + integral_status; where Kp is the proportional coefficient Ki is the integral coefficient = 1/Ti , where Ti is the integral time Ts is the regulator operating time (ranging from 200 to 400 microseconds based on carrier frequency).</p>	



NOTE

This parameter is **automatically computed and saved** when the Autotune procedure is performed (see the AUTOTUNE MENU).

P156 (P163, P170) Current Regulator Integral Time

P156 (Motor n.1) P163 (Motor n.2) P170 (Motor n.3)	Range	1 ÷ 32000	1.0 ÷ 32000. (Disabled)
	Default	200	20.0 ms
	Level	ENGINEERING	
	Address	756 763 (motor n.2) 770 (motor n.3)	
	Control	FOC	
	Function	<p>Ti Integral time of PI current regulator Id and Iq in the field rotary reference for motor n.1 (P166 and P170 relate to motors 2 and 3). The regulator's structure is as follows: error = Set_Point – Measure; integral_status = integral_status + error *Ki*Ts; Output = Kp*error + integral_status; where Kp is the proportional coefficient Ki is the integral coefficient = 1/Ti , where Ti is the integral time Ts is the regulator operating time (ranging from 200 to 400 microseconds based on carrier frequency).</p>	



NOTE

This parameter is **automatically computed and saved** when the Autotune procedure is performed (see the AUTOTUNE MENU).

P158 (P165, P172) Flux Regulator Proportional Constant

P158 (Motor n.1) P165 (Motor n.2) P172 (Motor n.3)	Range	0 ÷ 65000	0.00 ÷ 650.00
	Default	0	0.00
	Level	ENGINEERING	
	Address	758 765 772	
	Control	FOC	
	Function	<p>Kp Proportional coefficient of PI flux regulator for motor n.1 (P165 and P172 relate to motors 2 and 3). The regulator's structure is as follows: $error = Set_Point - Measure;$ $integral_status = integral_status + error * Ki * Ts;$ $Output = Kp * error + integral_status;$ where Kp is the proportional coefficient Ki is the integral coefficient = $1/Ti$, where Ti is the integral time Ts is the regulator operating time (ranging from 200 to 400 microseconds based on carrier frequency).</p>	

P159 (P166, P173) Flux Regulator Integral Time

P159 (Motor n.1) P166 (Motor n.2) P173 (Motor n.3)	Range	1 ÷ 32000	1.0 ÷ 32000. (Disabled)
	Default	33	33 ms
	Level	ENGINEERING	
	Address	759 766 773	
	Control	FOC	
	Function	<p>Ti Integral time of flux regulator PI for motor n.1 (P166 and P173 relate to parameters 2 and 3). The regulator's structure is as follows: $error = Set_Point - Measure;$ $integral_status = integral_status + error * Ki * Ts;$ $Output = Kp * error + integral_status;$ where Kp is the proportional coefficient Ki is the integral coefficient = $1/Ti$, where Ti is the integral time Ts is the regulator operating time (ranging from 200 to 400 microseconds based on carrier frequency).</p>	



NOTE Parameters P159-P166-P173 are **automatically recomputed and saved** whenever the Rotor Time Constant parameter (**C025**) is changed.

21. VTC REGULATORS MENU

21.1. Overview



NOTE A comprehensive review of the MOTOR CONFIGURATION MENU and the FIRST STARTUP section is recommended.



NOTE The VTC Regulators menu may be accessed only if the VTC Control is set up for one of the connected motors (**C010**=1 for motor N.1, **C053**=1 for motor N.2, **C096**=1 for motor N.3).

The sensorless VTC control algorithm is based on the same principles as the FOC algorithm, but instead of using the speed value read from the encoder, it exploits an estimated value of that speed value. Estimation is made possible via a dedicated status observer.

As is the case of the FOC algorithm, **two PI current regulators** are available.

The first regulator adjusts the **torque current (Iq)**, whilst the second regulator adjusts the **flux current (Id)**.

Torque current Iq is computed based on the torque setpoint required.

In **Slave Mode** (torque reference), the torque setpoint is required by the external reference; in **Master Mode**, the setpoint is given by the **speed regulator** (see SPEED LOOP AND CURRENT BALANCING MENU) that adjusts the motor speed of rotation.

Flux current Id is given by the output of the **flux regulator**, that keeps the motor fluxing correct.

The VTC Regulators menu includes the parameters of the current PI regulators and flux regulators for the VTC Control.

21.2. List of Parameters P175h1 to P175w

Table 35: List of Parameters P175a1 to P175w

Parameter	FUNCTION	User Level	DEFAULT VALUE	MODBUS Address
P175h1	Low-Frequency Flux Increment Percentage for Motor 1	ENGINEERING	0.0 %	684
P175i1	Minimum Frequency for Motor 1 Flux Increment	ENGINEERING	15.0 %	733
P175j1	Maximum Frequency for Motor 1 Flux Increment	ENGINEERING	30.0 %	734
P175t1	Proportional Gain of Motor 1 Current Controller	ENGINEERING	500.0	640
P175u1	Integral Time of Motor 1 Current Controller	ENGINEERING	50 ms	709
P175h2	Low-Frequency Flux Increment Percentage for Motor 2	ENGINEERING	0.0 %	1000
P175i2	Minimum Frequency for Motor 2 Flux Increment	ENGINEERING	15.0 %	1006
P175j2	Maximum Frequency for Motor 2 Flux Increment	ENGINEERING	30.0 %	1027
P175t2	Proportional Gain of Motor 2 Current Controller	ENGINEERING	500.0	641
P175u2	Integral Time of Motor 2 Current Controller	ENGINEERING	50 ms	732
P175h3	Low-Frequency Flux Increment Percentage for Motor 3	ENGINEERING	0.0 %	1005
P175i3	Minimum Frequency for Motor 3 Flux Increment	ENGINEERING	15.0 %	1007
P175j3	Maximum Frequency for Motor 3 Flux Increment	ENGINEERING	30.0 %	1049
P175t3	Proportional Gain of Motor 3 Current Controller	ENGINEERING	500.0	767
P175u3	Integral Time of Motor 3 Current Controller	ENGINEERING	50 ms	768
P175a	Current Distortion Threshold	ENGINEERING	5.00%	831
P175b	Current Distortion Compensation	ENGINEERING	80.00%	833
P175c	Current Distortion Compensation Allocation	ENGINEERING	50.00%	834
P175k	Extra-flux Percentage	ENGINEERING	110.0 %	727
P175l	Minimum Flux Percentage	ENGINEERING	10.0 %	742
P175o	Filter Time Constant of Flux Rate Limiter	ENGINEERING	300 ms	737
P175w	Type of Control at Stop with Start Open	ENGINEERING	Speed	611

P175h1 (P175h2, P175h3) Low-Frequency Flux Increment Percentage for Motor 1 (2,3)

P175h1 (Mot1) P175h2 (Mot2) P175h3 (Mot3)	Range	0 ÷ 1000	0.0 ÷ 100.0 %
	Default	0	0.0 %
	Level	ENGINEERING	
	Address	684, 1000, 1005	
	Control	VTC	
	Function	Percentage of the flux increment at low frequency. Indicates the increment percentage of the motor flux, in respect of its nominal value, adopted up to the frequency value displayed in P175i1 . The flux increment is dropped to 0 linearly with the frequency (flux equal to the nominal value) at the frequency value displayed in P175j1 .	

P175i1 (P175i2, P175i3) Minimum Frequency for Motor 1 (2,3) Flux Increment

P175i1 (Mot1) P175i2 (Mot2) P175i3 (Mot3)	Range	0 ÷ 1000	0.0 ÷ 100.0 %
	Default	150	15.0 %
	Level	ENGINEERING	
	Address	733, 1006, 1007	
	Control	VTC	
	Function	Minimum frequency of the interpolation for the flux increment at low frequency. Indicates the frequency (as a percentage of the rated frequency C015/C058/C101) up to which a flux increment equal to the value set in parameter P175h1 is adopted. See the description for P175h1 .	

P175j1 (P175j2, P175j3) Maximum Frequency for Motor 1 (2,3) Flux Increment

P175j1 (Mot1) P175j2 (Mot2) P175j3 (Mot3)	Range	0 ÷ 1000	0.0 ÷ 100.0 %
	Default	300	30.0 %
	Level	ENGINEERING	
	Address	734, 1027, 1049	
	Control	VTC	
	Function	Maximum frequency of the interpolation for the flux increment at low frequency. Indicates the frequency (as a percentage of the rated frequency C015/C058/C101) from which the nominal value of the flux is adopted. See the description for P175h1 .	

P175t1 (P175t2, P175t3) Proportional Gain of Motor 1 (2,3) Current Controller

P175t1 (Mot1) P175t2 (Mot2) P175t3 (Mot3)	Range	0 ÷ 32000	0.000 ÷ 3200.0
	Default	500	500.0
	Level	ENGINEERING	
	Address	640, 641, 767	
	Control	VTC	
	Function	Proportional gain of the torque and flux current control (d and q axis).	

P175u1 (P175u2, P175u3) Integral Time of Motor 1 (2,3) Current Controller

P175u1 (Mot1) P175u2 (Mot2) P175u3 (Mot3)	Range	1 ÷ 32000	1 ÷ 32000 ms [Disabled]
	Default	50	50 ms
	Level	ENGINEERING	
	Address	709, 732, 768	
	Control	VTC	
	Function	Integral time constant of the torque and flux current control (d and q axis).	



NOTE

Parameters **P175t1**, **P175u1** are automatically computed and saved by performing the autotune procedure **I074 = 1: Control NO rot]. or I074= [2: Control YES rot].**

P175a Current Distortion Threshold

P175a	Range	1 ÷ 10000	0.01 ÷ 100.00 %
	Default	500	5.00 %
	Level	ENGINEERING	
	Address	831	
	Control	VTC	
	Function	Current threshold for the compensation of positive and negative current distortion. The positive current compensation equal to P175b x P175c is applied to positive current values exceeding the rated drive current multiplied by the threshold set in P175a . The negative current compensation P175b x (100% - P175c) is applied to negative current values having absolute values greater than the rated drive current multiplied by P175a . When lower currents than the threshold currents are applied, compensation is obtained via linear pattern. Null current means null compensation. For tuning criteria, please refer to the FIRST STARTUP section.	

P175b Current Distortion Compensation

P175b	Range	-30000 ÷ 30000	-300.00 ÷ 300.00 %
	Default	8000	80.00 %
	Level	ENGINEERING	
	Address	833	
	Control	VTC	
	Function	Compensation to suppress current distortion due to dead times. That compensation activates when the positive current is greater than P175a (in respect to the rated drive current). See parameter P175a for a detailed description. For tuning criteria, please refer to the FIRST STARTUP section.	

P175c Current Distortion Compensation Allocation

P175c	Range	0 ÷ 10000	0 ÷ 100.00 %
	Default	5000	50.00 %
	Level	ENGINEERING	
	Address	834	
	Control	VTC	
	Function	Allocation of the compensation to suppress current distortion due to dead times between positive and negative current. See parameter P175a for a detailed description. For tuning criteria, please refer to the FIRST STARTUP section	

P175k Extra-flux Percentage

P175k	Range	1000 ÷ 1500	100.0 ÷ 150.0 %
	Default	1100	110.0 %
	Level	ENGINEERING	
	Address	727	
	Control	VTC	
	Function	Extra-flux percentage, in respect to the nominal flux, used when decelerating to increase the motor resistor losses and to dissipate the incoming energy produced by the motor in order to limit the DC bus voltage.	

P175l Minimum Flux

P175l	Range	0 ÷ 1000	0.0 ÷ 100.0 %
	Default	100	10.0 %
	Level	ENGINEERING	
	Address	742	
	Control	VTC	
	Function	Minimum reference flux expressed as a percentage with respect of the nominal flux.	

P175o Filter Time Constant of Flux Rate Limiter

P175o	Range	1 ÷ 32000	1 ÷ 32000 ms
	Default	300	300 ms
	Level	ENGINEERING	
	Address	737	
	Control	VTC	
	Function	Time constant of the filter adopted in the fluxing rate limiter.	

P175w Type of Control at Stop with START Open

P175w	Range	0 ÷ 1	0: Speed 1: Fluxing only
	Default	0	0: Speed
	Level	ENGINEERING	
	Address	611	
	Control	VTC	
	Function	Selects the type of control when the motor is stopped and the START input is open. The speed control is disabled if this parameter is set to 1: [Fluxing only] when the START input is open and the motor is stopped.	

22. ANALOG AND FREQUENCY OUTPUTS MENU

22.1. Overview



NOTE

Please refer to the Sinus Penta's Installation Guide for the hardware description of the analog output and the frequency output or for the configuration of the dip-switches for voltage/current outputs.



NOTE

MDO1 digital output is used when the frequency output is enabled (**P200** other than Disabled). Any configuration set in the DIGITAL OUTPUTS MENU will have no effect.

The Sinus Penta drive allows configuring three programmable analog outputs as voltage outputs or current outputs, as well as one frequency output.

22.1.1. FACTORY-SETTING OF THE ANALOG OUTPUTS

Analog outputs are factory set to voltage values ranging from $\pm 10V$ and the following variables are selected:

TERMINALS	OUTPUTS	SELECTED VARIABLE	OUTPUT RANGE	MIN. VALUE	MAX. VALUE
10	AO1	Speed (speed of the connected motor)	$\pm 10V$	-1500	1500
11	AO2	Speed Ref. (speed reference at constant rpm)	$\pm 10V$	-1500	1500
12	AO3	Current of the connected motor	$\pm 10V$	0	I _{max} *

* Depending on the inverter model.

22.1.2. ANALOG OUTPUTS

As per the analog outputs, the ANALOG AND FREQUENCY OUTPUTS MENU allows selecting the variable to be represented, its range, its acquisition mode (\pm or as an absolute value), the type of analog output (voltage/current) and the output values corresponding to the min. value and the max. value of the selected variable. An offset value and a filtering function may also be applied to the analog outputs. For the frequency output, this menu contains the parameters for the selection of the represented variable, its acquisition mode (\pm or as an absolute value), its min. value and max. value and the corresponding output frequency value, and a filtering function. The figure below shows the typical structure of the analog outputs; in particular, AO1 analog output and its parameter set are illustrated.

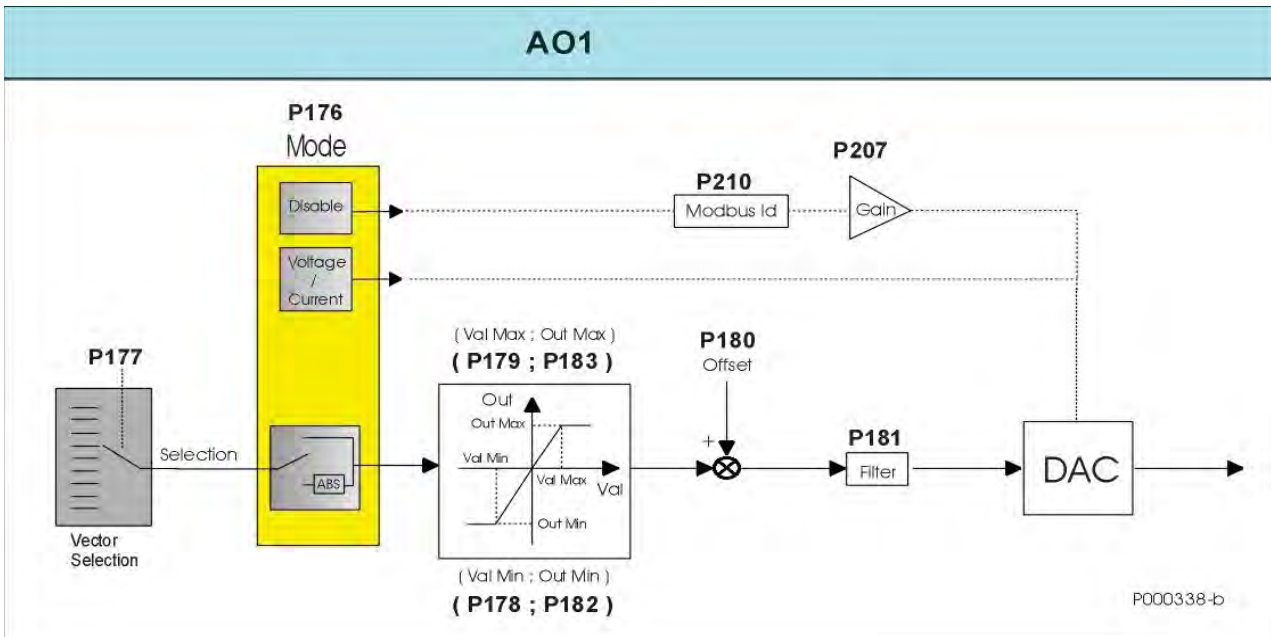

Figure 16: Typical structure of the Analog Outputs

- **Vector Selection** Selects the variable to be represented through the digital analog converter (DAC). **P177** is the selection parameter for AO1 analog output and **P185** and **P193** for AO2 and AO3 respectively.
- **Mode** Sets the acquisition mode of the selected variable (\pm or as an absolute value) and the type (voltage/current) for the analog output. If Mode = **Disable**, a different operating mode is activated for the analog output for which the represented variable is determined by the MODBUS address set in Address and the gain value set in Gain is applied:
P176 (Mode), **P207** (Gain), **P210** (Address) for AO1;
P184 (Mode), **P208** (Gain), **P211** (Address) for AO2;
P192 (Mode), **P209** (Gain), **P212** (Address) for AO3.
- **(Val Min; Out Min)** Defines the minimum saturation value of the variable to be represented and the corresponding value to be assigned to the analog output. For values equal to or lower than Val Min, Out Min will be assigned to the selected analog output. For analog outputs AO1, AO2, and AO3, the following parameters will be used: **(P178; P182)**, **(P186; P190)** and **(P194; P198)** for values **(Val Min; Out Min)**.
- **(Val Max; Out Max)** Defines the maximum saturation value of the variable to be represented and the corresponding value to be assigned to the analog output. For values equal to or higher than Val Max, Out Max will be assigned to the selected analog output. For analog outputs AO1, AO2, and AO3, the following parameters will be used: **(P179; P183)**, **(P187; P191)** and **(P195; P199)** for values **(Val Max; Out Max)**.
- **Offset** Defines the offset value applied to the analog output. Offset is set in parameter **P180** for AO1 analog output, in parameters **P188**, **P196** for AO2 and AO3 respectively.
- **Filter** Defines the filter time constant applied to the analog output. The filter time constant is set in parameter **P181** for AO1 analog output, in parameters **P189**, **P197** for AO2 and AO3 respectively.

22.1.3. FREQUENCY OUTPUT

When programming the frequency output, the setting of MDO1 in the DIGITAL OUTPUTS MENU is disabled. The figure below illustrates the structure of the frequency output. Parameterization is similar to the one used for the analog outputs.

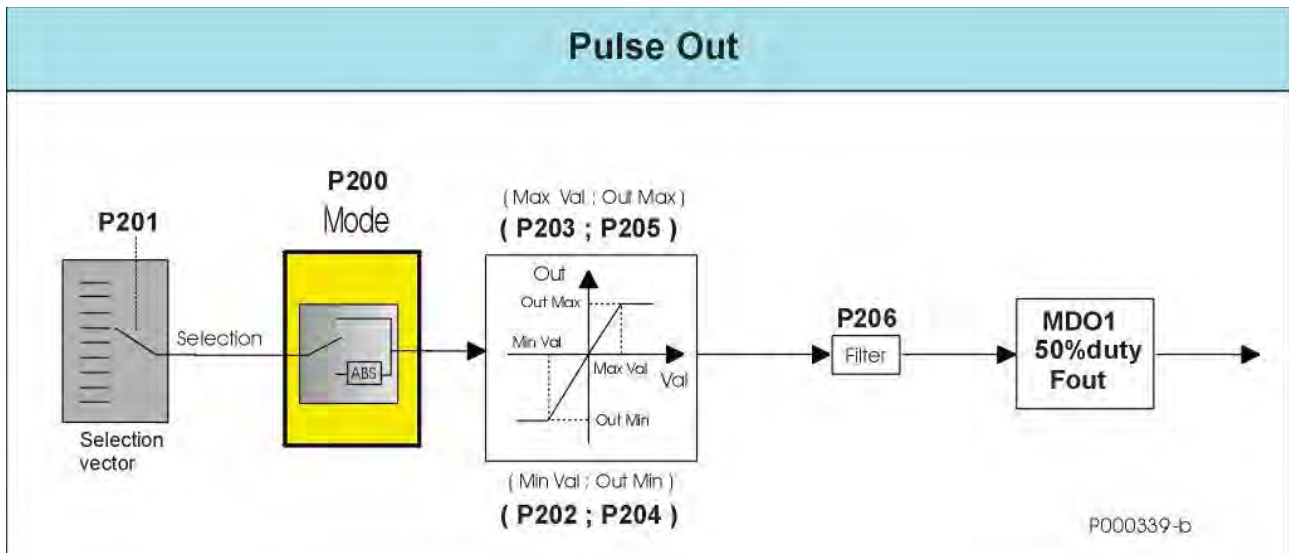

Figure 17: Structure of the Frequency Output

22.2. Variables

This section covers the variables that can be represented for the analog and frequency outputs.

Table 36: Selectable variables for the Analog and Frequency Outputs

SELECTION CODE		
Selection Value	Full-scale Value	Description
0: Disable		Disabled output
1: Speed	10000 rpm	Speed of the connected motor
2: Speed Ref.	10000 rpm	Speed reference at constant speed
3: Ramp Out	10000 rpm	"Ramped" speed reference
4: Mot. Freq.	1000.0 Hz	Frequency produced by the drive
5: Mot. Curr.	5000.0 A	Current RMS
6: Out Volt	2000.0 V	Output voltage RMS
7: OutPower	5000.0 kW	Output power
8: DC Vbus	2000.0 V	DC-link voltage
9: Torq.Ref	10000%	Torque reference at constant speed
10: Torq.Dem	10000 Nm	Torque demand (Nm)
11: Torq.Out	10000%	Estimated torque output
12: Torq.Lim	10000%	Setpoint of the torque limit
13: PID Ref%	100.00%	PID reference at constant speed
14: PID RMP%	100.00%	"Ramped" PID reference
15: PID Err%	100.00%	Error between PID reference and feedback
16: PID Fbk%	100.00%	Feedback to the PID
17: PID Out%	100.00%	Output of the PID
18: REF	100.00%	Analog input REF
19: AIN1	100.00%	Analog input AIN1
20: AIN2/PTC	100.00%	Analog input AIN2
21: Enc. In	10000 rpm	Speed read by the encoder used as a reference
22: Pulseln	100.00 kHz	Frequency input
23: Flux Ref	1.0000 Wb	Flux reference at constant speed
24: Flux	1.0000 Wb	Current flux reference
25: iq ref.	5000.0 A	Current reference in axis q
26: id ref.	5000.0 A	Current reference in axis d
27: iq	5000.0 A	Current measure in axis q
28: id	5000.0 A	Current measure in axis d
29: Volt.Vq	2000.0 V	Voltage in axis q
30: Volt Vd	2000.0 V	Voltage in axis d
31: Cosine	100.00%	Cosine waveform
32: Sine	100.00%	Sine waveform
33: Angle	1.0000 rad	Electric angle of delivered Vu
34: +10V	10.000 V	Voltage level +10V
35: -10V	10.000 V	Voltage level -10V
36: Flux Current	5000.0 A	Flux Current
37: Sqr Wave	100.00%	Square wave
38: Saw Wave	100.00%	Saw wave
39: Hts Temp.	100.00 °C	Temperature of the heatsink
40: Amb Temp.	100.00 °C	Ambient temperature
41+49: RESERVED		RESERVED
50: PT100_1	100.00%	PT100 Channel 1
51: PT100_2	100.00%	PT100 Channel 2
52: PT100_3	100.00%	PT100 Channel 3
53: PT100_4	100.00%	PT100 Channel 4
54: I2t%	100.00%	Motor thermal capacity
55: XAIN4	100.00%	XAIN4 Analog input
56: XAIN5	100.00%	XAIN5 Analog input
57: OT Count	100000h	Maintenance Operation Time Counter
58: ST Count	100000h	Maintenance Supply Time Counter

59: PID2 Reference	100.00%	Reference at constant speed of PID2
60: PID2 Set Point	100.00%	"Ramped" reference of PID2
61: PID2 Feedback	100.00%	PID2 Feedback
62: PID2 Error	100.00%	Error between reference and feedback of PID2
63: PID2 Out	100.00%	Output of PID2
64: Torque Demand	100.00%	Torque demand (value percent)
65: Actual Current Iv	5000A	Output Current Iv
66: RESERVED		RESERVED
67: RESERVED		RESERVED
68: RESERVED		RESERVED
69: RESERVED		RESERVED

Table 36 provides a brief description of each variable and its full-scale value used to set the minimum and maximum value.

22.2.1. OPERATING MODE OF ANALOG AND FREQUENCY OUTPUTS

This section covers the different representation modes to be selected for the analog and frequency outputs.

The following modes can be used for analog outputs:

- 0: Disabled** Disabled analog output (enables a RESERVED operating mode).
- 1: ± 10V** The analog output is set as a voltage output and the possible min. and max. output values range from +/– 10V. The selected variable has a positive or negative sign.
- 2: 0÷10V** The analog output is set as a voltage output and the possible min. and max. output values range from 0 to 10V. The selected variable has a positive or negative sign.
- 3: 0÷20mA** The analog output is set as a current output and the possible min. and max. output values range from 0 to 20mA. The selected variable has a positive or negative sign.
- 4: 4÷20mA** The analog output is set as a current output and the possible min. and max. output values range from 4 to 20mA. The selected variable has a positive or negative sign.
- 5: ABS 0÷10V** As 0÷10V output mode, but the selected variable is considered as an absolute value.
- 6: ABS 0÷20mA** As 0÷20mA output mode, but the selected variable is considered as an absolute value.
- 7: ABS 4÷20mA** As 4÷20mA output mode, but the selected variable is considered as an absolute value.



NOTE

Always check the min. and max. values of the outputs programmed in the relevant parameters.

Three operating modes can be selected for the **Frequency Output**:

- 0: Disabled** The output frequency is disabled.
- 1: Pulse Out** MDO1 Digital Output is programmed as a frequency output. The selected variable has a positive or negative sign.
- 2: ABS Pulse Out** As Pulse Out, but the selected variable is considered as an absolute value.



NOTE

When **P200** is not set to DISABLE, MDO1 digital output is used as a frequency output and any MDO1 settings in the DIGITAL OUTPUTS MENU are ignored.

22.2.2. ANALOG OUTPUT PROGRAMMING EXAMPLES

This section contains a description of operating examples of the analog outputs obtained with different programming modes.

Example 1:

Table 37: Programming AO1 (0 ÷ 10V)

Parameterization of AO1 Analog Output		
Parameter	Value	Description
P176	0÷10V	AO1 Analog output
P177	1: Speed	Selected variable for AO1 analog output
P178	-500 rpm	Min. value of AO1 selected variable
P179	+500 rpm	Max. value of AO1 selected variable
P180	0.000 V	AO1 Analog output offset
P181	0 ms	Filter for AO1 analog output
P182	0.0 V	Min. AO1 output value with reference to P178
P183	10.0 V	Max. AO1 output value with reference to P179

Figure 18: Curve (voltage; speed) implemented by AO1 (Example 1)

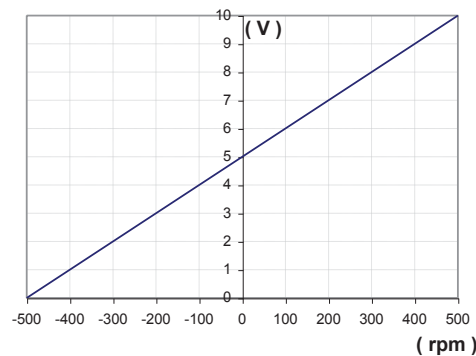

Example 2:

Table 38: Programming AO1 (0 ÷ 10V)

Parameterization of Analog Output AO1		
Parameter	Value	Description
P176	ABS 0÷10V	AO1 Analog output
P177	1: Speed	Selected variable for AO1 analog output
P178	0 rpm	Min. value of AO1 selected variable
P179	+500 rpm	Max. value of AO1 selected variable
P180	0.000 V	AO1 Analog output offset
P181	0 ms	Filter for AO1 analog output
P182	0.0 V	Min. AO1 output value with reference to P178
P183	10.0 V	Max. AO1 output value with reference to P179

Figure 19: Curve (voltage; speed) implemented by AO1 (Example 2)

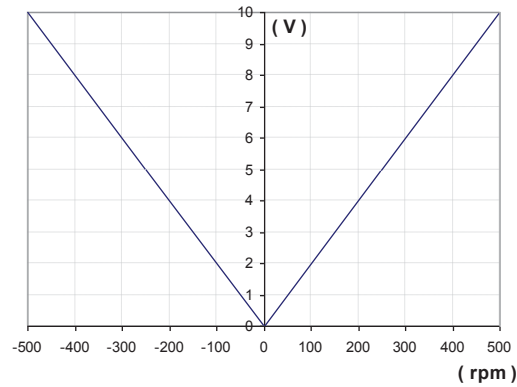

Example 3:

Table 39: Programming AO1 (ABS 0 ÷ 10V)

Parameterization of Analog Output AO1		
Parameter	Value	Description
P176	ABS 0÷10V	AO1 Analog output
P177	1: Speed	Selected variable for AO1 analog output
P178	-500 rpm	Min. value of AO1 selected variable
P179	+500 rpm	Max. value of AO1 selected variable
P180	0.000 V	AO1 Analog output offset
P181	0 ms	Filter for AO1 analog output
P182	0.0 V	Min. AO1 output value with reference to P178
P183	10.0 V	Max. AO1 output value with reference to P179

Figure 20: Curve (voltage; speed) implemented by AO1 (Example 3)

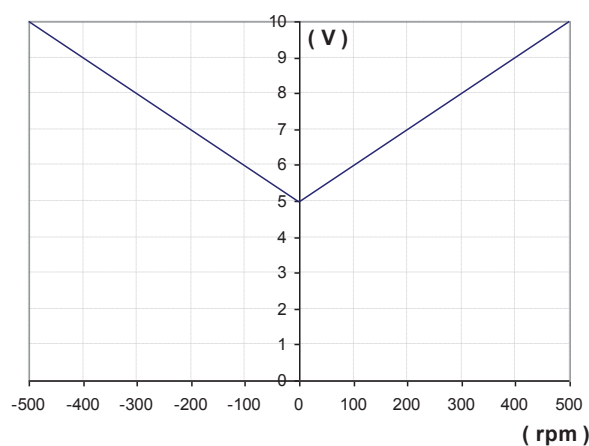

NOTE

The programming mode above would imply a straight line passing through (-500rpm; 0V) and (+500rpm; 10V), but based on the selected mode and considering the variable as an absolute value, the min. point for output AO1 will be (0 rpm; 5 V).

Example 4:

Table 40: Programming AO1 (ABS 0 ÷ 10V)

Parameterization of Analog Output AO1		
Parameter	Value	Description
P176	ABS 0÷10V	AO1 Analog output
P177	1: Speed	Selected variable for AO1 analog output
P178	+100 rpm	Min. value of AO1 selected variable
P179	+500 rpm	Max. value of AO1 selected variable
P180	0.000 V	AO1 Analog output offset
P181	0 ms	Filter for AO1 analog output
P182	0.0 V	Min. AO1 output value with reference to P178
P183	10.0 V	Max. AO1 output value with reference to P179

Figure 21: Curve (voltage; speed) implemented by AO1 (Example 4)

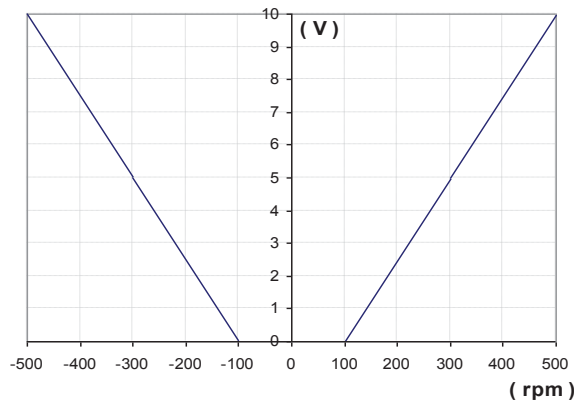

Example 5:

Table 41: Programming AO1 (± 10V)

Parameterization of Analog Output AO1		
Parameter	Value	Description
P176	±10V	AO1 Analog output
P177	1: Speed	Selected variable for AO1 analog output
P178	+500 rpm	Min. value of AO1 selected variable
P179	-500 rpm	Max. value of AO1 selected variable
P180	0.000 V	AO1 Analog output offset
P181	0 ms	Filter for AO1 analog output
P182	-10.0 V	Min. AO1 output value with reference to P178
P183	+10.0 V	Max. AO1 output value with reference to P179

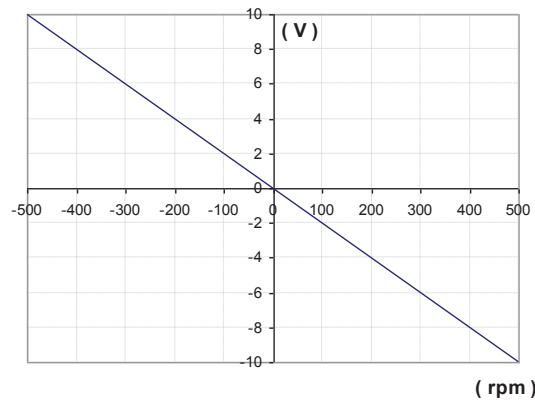

Figure 22: Curve (voltage; speed) implemented by AO1 (Example 5)

22.3. List of Parameters P176 to P215

Table 42: List of Parameters P176 to P215

Param.	Function	User Level	DEFAULT VALUES	Modbus Address
P176	AO1 analog output	ADVANCED	1: $\pm 10V$	776
P177	Selected variable for AO1 analog output	ADVANCED	1: Motor speed	777
P178	Min. value of AO1 selected variable	ADVANCED	-1500 rpm	778
P179	Max. value of AO1 selected variable	ADVANCED	+1500 rpm	779
P180	AO1 Analog output offset	ADVANCED	0.000 V	780
P181	Filter for AO1 analog output	ADVANCED	0 ms	781
P182	Min. AO1 output value with reference to P178	ADVANCED	-10.0 V	782
P183	Max. AO1 output value with reference to P179	ADVANCED	+10.0V	783
P184	AO2 analog output	ADVANCED	1: $\pm 10V$	784
P185	Selected variable for AO2 analog output	ADVANCED	2: Speed reference at constant rpm	785
P186	Min. value of AO2 selected variable	ADVANCED	-1500 rpm	786
P187	Max. value of AO2 selected variable	ADVANCED	+1500 rpm	787
P188	AO2 Analog output offset	ADVANCED	0.000 V	788
P189	Filter for AO2 analog output	ADVANCED	0 ms	789
P190	Min. AO2 output value with reference to P186	ADVANCED	-10.0 V	790
P191	Max. AO2 output value with reference to P187	ADVANCED	+10.0V	791
P192	AO3 analog output	ADVANCED	2: 0÷10V	792
P193	Selected variable for AO3 analog output	ADVANCED	5: Output current	793
P194	Min. value of AO3 selected variable	ADVANCED	0 A	794
P195	Max. value of AO3 selected variable	ADVANCED	Inverter I _{max}	795
P196	AO3 Analog output offset	ADVANCED	0.000 V	796
P197	Filter for AO3 analog output	ADVANCED	0 ms	797
P198	Min. AO3 output value with reference to P194	ADVANCED	0.0 V	798
P199	Max. AO3 output value with reference to P195	ADVANCED	+10.0V	799
P200	FOUT output in [MDO1] frequency	ADVANCED	0: Disabled	800
P201	Selected variable for FOUT frequency output	ADVANCED	1: Motor speed	801
P202	Min. FOUT value of selected variable	ADVANCED	0	802
P203	Max. FOUT value of selected variable	ADVANCED	0	803
P204	Min. FOUT output value with reference to P202	ADVANCED	10.00 kHz	804
P205	Max. FOUT output value with reference to P203	ADVANCED	100.00 kHz	805
P206	Filter for FOUT frequency output	ADVANCED	0 ms	806
P207	AO1: Gain	ADVANCED	RESERVED	807
P208	AO2: Gain	ADVANCED		808
P209	AO3: Gain	ADVANCED		809
P210	AO1: Variable MODBUS address	ADVANCED		810
P211	AO2: Variable MODBUS address	ADVANCED		811
P212	AO3: Variable MODBUS address	ADVANCED		812
P213	Amplitude of sinusoidal analog output signal	ENGINEERING	100.0%	813
P214	Frequency of sinusoidal analog output signal	ENGINEERING	1.00 Hz	814
P215	Frequency of saw wave analog output signal	ENGINEERING	1.00 Hz	815

P176 AO1 Analog Output

P176	Range	0 ÷ 7	0: Disabled, 1: ± 10V, 2: 0 ÷ 10V, 3: 0 ÷ 20mA, 4: 4 ÷ 20mA, 5: ABS 0 ÷ 10V, 6: ABS 0 ÷ 20mA, 7: ABS 4 ÷ 20mA.
	Default	1	1: ± 10V
	Level	ADVANCED	
	Address	776	
	Function	Selects the operating mode of AO1 analog output.	

P	1	7	6	T	y	p	e	o	f
O	u	t	p	u	t	S	i	g	n
A	O	1		S	W	2	-	1	-
→			0	-	2	0	m	A	
								<input type="checkbox"/>	<input checked="" type="checkbox"/>

In the example above, AO1 is set as a current input. Contact 1 of SW2 dip-switch is open, contact 2 is closed.



NOTE

Analog outputs are set as voltage outputs by default. To set them as current outputs, see the DIP-switch configuration and follow the instructions displayed on the keypad, or refer to the Sinus Penta's Installation Guide.

P177 Selected Variable for AO1 Analog Output

P177	Range	0 ÷ 69	See Table 36
	Default	1	Motor speed
	Level	ADVANCED	
	Address	777	
	Function	Selects the variable to be allocated to AO1 digital output.	

P178 Min. value of AO1 Selected Variable

P178	Range	-32000 ÷ +32000 Depending on the value selected in P177	- 320.00% ÷ + 320.00 % of the full-scale value See Table 36
	Default	-1500	-15.00% of 10000 rpm = -1500 rpm
	Level	ADVANCED	
	Address	778	
	Function	Minimum value of the variable selected via P177 , corresponding to the min. output value of AO1 set in P182 .	

P179 Max. value of AO1 Selected Variable

P179	Range	-32000 ÷ +32000 Depending on the value selected in P177	- 320.00% ÷ + 320.00 % of the full-scale value See Table 36
	Default	+1500	+15.00% of 10000 rpm = +1500 rpm
	Level	ADVANCED	
	Address	779	
	Function	Maximum value of the variable selected via P177 , corresponding to the max. output value of AO1 set in P183 .	

P180 AO1 Analog Output Offset

P180	Range	-9999 ÷ +9999 Depending on the value selected in P176	-9.999 ÷ +9.999
	Default	0	0.000 V
	Level	ADVANCED	
	Address	780	
	Function	Offset value applied to AO1 analog output.	

P181 Filter for AO1 Analog Output

P181	Range	0 ÷ 65000	0.000 ÷ 65.000 sec.
	Default	0	0.000 sec.
	Level	ADVANCED	
	Address	781	
	Function	Value of the filter time constant applied to AO1 analog output.	

P182 Min. AO1 Output Value with Reference to P178

P182	Range	-100 ÷ +100 -200 ÷ +200 Depending on the value selected in P176	-10.0 ÷ +10.0 V -20.0 ÷ +20.0 mA
	Default	-100	-10.0 V
	Level	ADVANCED	
	Address	782	
	Function	Minimum output value obtained when the minimum value of the variable set in P178 is implemented.	

P183 Max. AO2 Output Value with Reference to P179

P183	Range	-100 ÷ +100 -200 ÷ +200 Depending on the value selected in P176	-10.0 ÷ +10.0 V -20.0 ÷ +20.0 mA
	Default	+100	+10.0 V
	Level	ADVANCED	
	Address	783	
	Function	Maximum output value obtained when the maximum value of the variable set in P179 is implemented.	

P184 AO2 Analog Output

P184	Range	0 ÷ 7	0: Disabled, 1: ± 10V, 2: 0 ÷ 10V, 3: 0 ÷ 20mA, 4: 4 ÷ 20mA, 5: ABS 0 ÷ 10V, 6: ABS 0 ÷ 20mA, 7: ABS 4 ÷ 20mA.
	Default	1	1: ± 10V
	Level	ADVANCED	
	Address	784	
	Function	Selects the operating mode of AO2 analog output.	



NOTE

Analog outputs are set as voltage outputs by default. To set them as current outputs, see the DIP-switch configuration and follow the instructions displayed on the keypad, or refer to the Sinus Penta's Installation Guide.

P185 Selected Variable for AO2 Analog Output

P185	Range	0 ÷ 69	See Table 36
	Default	2	Reference at constant speed
	Level	ADVANCED	
	Address	785	
	Function	Selects the variable to be allocated to AO2 digital output.	

P186 Min. Value of AO2 Selected Variable

P186	Range	-32000 ÷ +32000 Depends on the value selected in P185	-320.00 % ÷ +320.00 % of the full-scale value See Table 36
	Default	-1500	-1500 rpm
	Level	ADVANCED	
	Address	786	
	Function	Minimum value of the variable selected via P185 , corresponding to the min. output value of AO2 set in P190 .	

P187 Max. value of AO2 Selected Variable

P187	Range	-32000 ÷ +32000 Depends on the value selected in P185	-320.00 % ÷ +320.00 % of the full-scale value See Table 36
	Default	+1500	+1500 rpm
	Level	ADVANCED	
	Address	787	
	Function	Maximum value of the variable selected via P185 , corresponding to the max. output value of AO2 set in P191 .	

P188 AO2 Analog Output Offset

P188	Range	-9999 ÷ +9999 Depends on the value selected in P184	-9.999 ÷ 9.999
	Default	0	0.000 V
	Level	ADVANCED	
	Address	788	
	Function	Offset value applied to AO2 analog output.	

P189 Filter for AO2 Analog Output

P189	Range	0 ÷ 65000	0.000 ÷ 65.000 sec.
	Default	0	0.000 sec.
	Level	ADVANCED	
	Address	789	
	Function	Value of the filter time constant applied to AO2 analog output.	

P190 Min. AO2 Output Value with Reference to P186

P190	Range	-100 ÷ +100 -200 ÷ +200 Depends on the value selected in P184	-10.0 ÷ +10.0 V -20.0 ÷ +20.0 mA
	Default	-100	-10.0 V
	Level	ADVANCED	
	Address	790	
	Function	Minimum output value obtained when the minimum value of the variable set in P186 is implemented.	

P191 Max. AO2 Output Value with Reference to P187

P191	Range	-100 ÷ +100 -200 ÷ +200 Depends on the value selected in P184	-10.0 ÷ +10.0 V -20.0 ÷ +20.0 mA
	Default	+100	+10,0 V
	Level	ADVANCED	
	Address	791	
	Function	Maximum output value obtained when the maximum value of the variable set in P187 is implemented.	

P192 AO3 Analog Output

P192	Range	0 ÷ 7	0: Disabled, 1: ± 10V, 2: 0 ÷ 10V, 3: 0 ÷ 20mA, 4: 4 ÷ 20mA, 5: ABS 0 ÷ 10V, 6: ABS 0 ÷ 20mA, 7: ABS 4 ÷ 20mA.
	Default	2	2: 0 ÷ 10V
	Level	ADVANCED	
	Address	792	
	Function	Selects the operating mode of AO3 analog output.	

**NOTE**

Analog outputs are set as voltage outputs by default. To set them as current outputs, see the DIP-switch configuration and follow the instructions displayed on the keypad, or refer to the Sinus Penta's Installation Guide.

P193 Selected Variable for AO3 Analog Output

P193	Range	0 ÷ 69	See Table 36
	Default	5	5: Motor current
	Level	ADVANCED	
	Address	793	
	Function	Selects the variable to be allocated to AO3 analog output.	

P194 Min. Value of AO3 Selected Variable

P194	Range	-320.00 % ÷ +320.00 % of the full-scale value Depends on the value selected through P193	-320.00 % ÷ +320.00 % of the full-scale value See Table 36
	Default	0	0 A
	Level	ADVANCED	
	Address	794	
	Function	Minimum value of the variable selected via P193 , corresponding to the min. output value of AO3 set in P198 .	

P195 Max. Value of AO3 Selected Variable

P195	Range	-320.00 % ÷ +320.00 % Depends on the value selected through P193	-320.00 % ÷ +320.00 % of the full-scale value See Table 36
	Default	Inverter I _{max}	Max. drive current depending on the drive model – see Table 81 and Table 85
	Level	ADVANCED	
	Address	795	
	Function	Maximum value of the variable selected via P193 , corresponding to the max. output value of AO3 set in P199 .	

P196 AO3 Analog Output Offset

P196	Range	-9999 ÷ +9999 Depends on the value selected through P192	-9.999 ÷ +9.999
	Default	0	0.000 V
	Level	ADVANCED	
	Address	796	
	Function	Offset value applied to AO3 analog output.	

P197 Filter for AO3 Analog Output

P197	Range	0 ÷ 65000 sec.	0.000 ÷ 65.000 sec.
	Default	0	0.000 sec.
	Level	ADVANCED	
	Address	797	
	Function	Value of the filter time constant applied to AO3 analog output.	

P198 Min. AO3 Output Value with Reference to P194

P198	Range	-100 ÷ +100 -200 ÷ +200 Function according to the selection of P192	-10.0 ÷ +10.0 V -20.0 ÷ +20.0 mA
	Default	0	00.0 V
	Level	ADVANCED	
	Address	798	
	Function	Minimum output value obtained when the minimum value of the variable set in P194 is implemented.	

P199 Max. AO3 Output Value with Reference to P195

P199	Range	-100 ÷ +100 -200 ÷ +200 Function according to selection of P192	-10.0 ÷ +10.0 V -20.0 ÷ +20.0 mA
	Default	+100	+10.0 V
	Level	ADVANCED	
	Address	799	
	Function	Maximum output value obtained when the maximum value of the variable set in P195 is implemented.	

P200 FOUT Output in [MDO1] Frequency

P200	Range	0 ÷ 2	0: Disabled, 1: Pulse, 2: ABS Pulse
	Default	0	0: Disabled
	Level	ADVANCED	
	Address	800	
	Function	Selects the operating mode of FOUT frequency output.	

NOTE

When **P200** is not set to DISABLE, MDO1 digital output is used as a frequency output and any settings for MDO1 in the DIGITAL OUTPUTS MENU are ignored.

P201 Selected Variable for FOUT Frequency Output

P201	Range	0 ÷ 69	See Table 36
	Default	1	Motor speed
	Level	ADVANCED	
	Address	801	
	Function	Selects the variable to be allocated to FOUT frequency output.	

P202 Min. FOUT Value of Selected Variable

P202	Range	-32000 ÷ +32000 Depends on the value selected through P201	-320.00 % ÷ +320.00 % of the full-scale value See Table 36
	Default	0	0
	Level	ADVANCED	
	Address	802	
	Function		

	Function	Minimum value of the selected variable.
--	-----------------	---

P203 Max. FOUT Value of Selected Variable

P203	Range	-32000 ÷ +32000 Depends on the value selected through P201	-320.00 % ÷ +320.00 % of the full-scale value See Table 36
	Default	0	0
	Level	ADVANCED	
	Address	803	
	Function	Maximum value of the selected variable.	

P204 Min. FOUT Output Value with Reference to P202

P204	Range	1000÷10000	10.00÷100.00 kHz
	Default	1000	10.00 kHz
	Level	ADVANCED	
	Address	804	
	Function	Minimum output value obtained when the minimum value of the variable set in P202 is implemented.	

P205 Min. FOUT Output Value with Reference to P203

P205	Range	1000÷10000	10.00÷100.00 kHz
	Default	10000	100.00 kHz
	Level	ADVANCED	
	Address	805	
	Function	Maximum output value obtained when the maximum value of the variable set in P203 is implemented.	

P206 Filter for FOUT Frequency Output

P206	Range	0 ÷ 65000	0.000 ÷ 65.000 sec
	Default	0	0.000 sec.
	Level	ADVANCED	
	Address	806	
	Function	Value of the filter time constant applied to FOUT frequency output.	

P207 AO1: Gain

P208 AO2: Gain

P209 AO3: Gain

P210 AO1: Variable MODBUS Address

P211 AO2: Variable MODBUS Address

P212 AO3: Variable MODBUS Address

RESERVED

P213 Amplitude of Sinusoidal Analog Output Signal

P213	Range	0 ÷ 1000	0 ÷ 100.0%
	Default	1000	100.0%
	Level	ENGINEERING	
	Address	813	
	Function	Amplitude of the sinusoidal analog output signal when Sine or Cosine variables are selected.	

P214 Frequency of Sinusoidal Analog Output Signal

P214	Range	0 ÷ 20000	0 ÷ 200.00Hz
	Default	100	1.00Hz
	Level	ENGINEERING	
	Address	814	
	Function	Frequency of the sinusoidal analog output signal when Sine or Cosine variables are selected.	

P215 Frequency of Saw Wave Analog Output Signal

P215	Range	0 ÷ 20000	0 ÷ 200.00Hz
	Default	100	1.00Hz
	Level	ENGINEERING	
	Address	815	
	Function	Frequency of saw wave analog output signal when Sine or Cosine variables are selected. This can be used as the carrier frequency when setting MDO1 or MDO2 in PWM mode (see the example given in the DIGITAL OUTPUTS MENU).	

23. TIMERS MENU

23.1. Overview

The Timers menu allows setting enable and disable delay times for digital inputs/outputs.

NOTE

For the **ENABLE-A** and **ENABLE-B** digital inputs, no disable delay is allowed, because their logic status is utilized directly by the hardware activating IGBT switching; when no **ENABLE-A**, **ENABLE-B** command is sent, the output power stage is instantly deactivated.

NOTE

The **ENABLE-A** and **ENABLE-B** inputs are allocated to the STO function. If this safety function is to be adopted, the control mode and the control circuit of these signals must be accomplished as per the Safe Torque Off Function - Application Manual. That manual also includes a detailed validation procedure of the control configuration of the STO function to be executed upon first start-up and also periodically at yearly intervals.

NOTE

The reset function for the alarms on the leading edges of MDI3 is not delayed.

NOTE

Any auxiliary alarm set to the digital inputs is not delayed.

NOTE

Five timers are available; the user can set an enabling/disable delay for each of them. The same timer may also be assigned to multiple digital inputs/outputs.

NOTE

The ENABLE-SW function cannot be delayed.

Example 1:

The drive enable (**MDI1 START**) depends on a signal coming from a different source. An activation delay of 2 seconds and a deactivation delay of 5 seconds are needed. To do so, set two delay times for activation and deactivation for the same timer and assign it to **MDI1 (START)** digital input. In the example below, timer 1 is used.

P216	2.0 sec	Activation delay T1
P217	5.0 sec	Deactivation delay T1
P226	0x0001	Timer assigned to MDI1 (START)

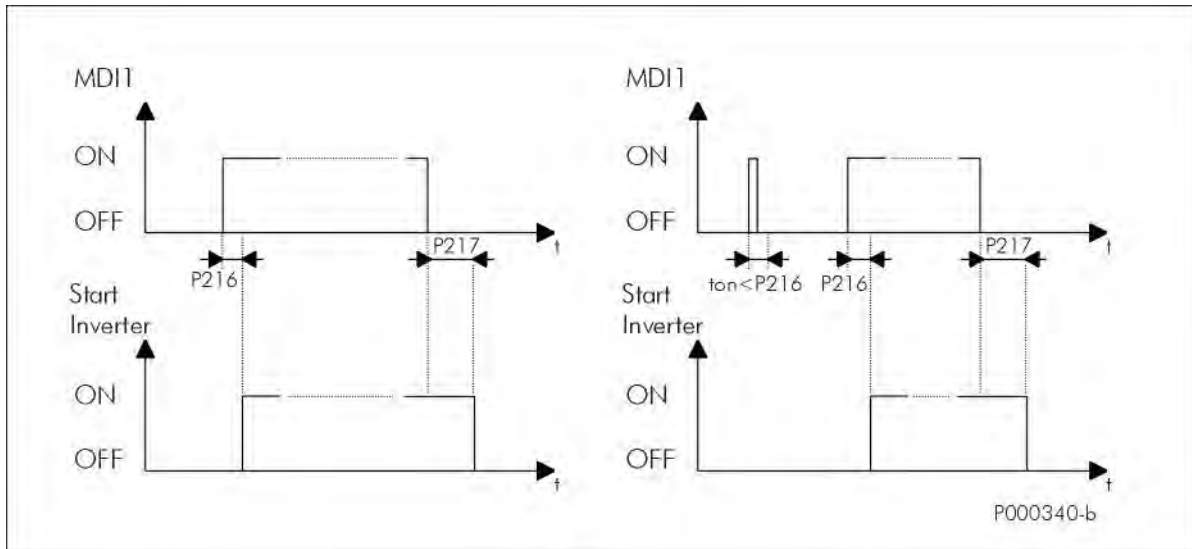

Figure 23: Using Timers (example)

The figure shows two possible operating modes:

- on the left: application of the delay times set for the drive enabling/disabling;
- on the right: the start signal persists for a shorter time than the delay set for enabling; in this case, the Start function is not enabled. The Start function will be enabled only when MDI1 digital input is ON for a time longer than the time set in P216.

23.2. List of Parameters P216 to P229

Table 43: List of Parameters P216 to P229

Parameter	FUNCTION	User Level	Default Values	MODBUS Address
P216	T1 Enable delay	ENGINEERING	0.0	816
P217	T1 Disable delay	ENGINEERING	0.0	817
P218	T2 Enable delay	ENGINEERING	0.0	818
P219	T2 Disable delay	ENGINEERING	0.0	819
P220	T3 Enable delay	ENGINEERING	0.0	820
P221	T3 Disable delay	ENGINEERING	0.0	821
P222	T4 Enable delay	ENGINEERING	0.0	822
P223	T4 Disable delay	ENGINEERING	0.0	823
P224	T5 Enable delay	ENGINEERING	0.0	824
P225	T5 Disable delay	ENGINEERING	0.0	825
P226	Timer assigned to inputs MDI1÷4	ENGINEERING	0: No timer assigned	826
P227	Timer assigned to inputs MDI5÷8	ENGINEERING	0: No timer assigned	827
P228	Timer assigned to outputs MDO1÷4	ENGINEERING	0: No timer assigned	828
P229	Timer assigned to virtual outputs MPL1÷4	ENGINEERING	0: No timer assigned	829

P216 T1 Enable delay

P216	Range	0 ÷ 60000	0.0 ÷ 6000.0 sec
	Default	0	0.0
	Level	ENGINEERING	
	Address	816	
	Function	This parameter sets T1 enable time. Using P226 or P227 , if timer T1 is assigned to a digital input having a particular function, P216 represents the delay occurring between the input closure and the function activation. Use P228 to assign timer 1 to a digital output; in that case, the digital output energizing will be delayed according to the time set in P216 .	

P217 T1 Disable delay

P217	Range	0 ÷ 60000	0.0 ÷ 6000.0 sec
	Default	0	0.0
	Level	ENGINEERING	
	Address	817	
	Function	This parameter sets T1 disabling time. Using P226 or P227 , if timer T1 is assigned to a digital input having a particular function, this parameter represents the delay occurring between the input opening and the function deactivation. Use P228 to assign timer 1 to a digital output; in that case, the digital output de-energizing will be delayed according to the time set in P217 .	

P218 T2 Enable delay

P218	Range	0 ÷ 60000	0.0 ÷ 6000.0 sec
	Default	0	0.0
	Level	ENGINEERING	
	Address	818	
	Function	This parameter sets T2 enable time. (Operation as per P216 .)	

P219 T2 Disable delay

P219	Range	0 ÷ 60000	0.0 ÷ 6000.0 sec
	Default	0	0.0
	Level	ENGINEERING	
	Address	819	
	Function	This parameter sets T2 disable time. (Operation as per P217 .)	

P220 T3 Enable delay

P220	Range	0 ÷ 60000	0.0 ÷ 6000.0 sec
	Default	0	0.0
	Level	ENGINEERING	
	Address	820	
	Function	This parameter sets T3 enable time. (Operation as per P216 .)	

P221 T3 Disable delay

P221	Range	0 ÷ 60000	0.0 ÷ 6000.0 sec
	Default	0	0.0
	Level	ENGINEERING	
	Address	821	
	Function	This parameter sets T3 disable time. (Operation as per P217 .)	

P222 T4 Enable delay

P222	Range	0 ÷ 60000	0.0 ÷ 6000.0 sec
	Default	0	0.0
	Level	ENGINEERING	
	Address	822	
	Function	This parameter sets T4 enable time. (Operation as per P216 .)	

P223 T4 Disable delay

P223	Range	0 ÷ 60000	0.0 ÷ 6000.0 sec
	Default	0	0.0
	Level	ENGINEERING	
	Address	823	
	Function	This parameter sets T4 disable time. (Operation as per P217 .)	

P224 T5 Enable delay

P224	Range	0 ÷ 60000	0.0 ÷ 6000.0 sec
	Default	0	0.0
	Level	ENGINEERING	
	Address	824	
	Function	This parameter sets T5 enable time. (Operation as per P216 .)	

P225 T5 Disable delay

P225	Range	0 ÷ 60000	0.0 ÷ 6000.0 sec
	Default	0	0.0
	Level	ENGINEERING	
	Address	825	
	Function	This parameter sets T5 disable time. (Operation as per P217 .)	

P226 Timers Assigned to Inputs MDI1+4

P226	Range	[0; 0; 0; 0] ÷ [5; 5; 5; 5]	0: No timer assigned 1 ÷ 5: T1 ÷ T5
	Default	[0; 0; 0; 0]	0: No timer assigned
	Level	ENGINEERING	
	Address	826	
	Function	The first group of four digital inputs may be assigned to any of the five timers and the same timer may be assigned to multiple inputs. Select "zero" to avoid delaying the digital inputs. Setting via serial link: see Table 44.	

Table 44: Coding of Parameters P226 to P229

bits [15..12]	bits [11..9]	bits [8..6]	bits [5..3]	bits [2..0]
not used	MDI4	MDI3	MDI2	MDI1

Coding example for P226:

MDI1=Timer T2
 MDI2=No timer assigned
 MDI3=Timer T2
 MDI4=Timer T5
 ⇒ value in **P226** 101 010 000 010 bin = 2690 dec

P227 Timers Assigned to Inputs MDI5+8

P227	Range	[0; 0; 0; 0] ÷ [5; 5; 5; 5]	0: No timer assigned 1 ÷ 5: T1 ÷ T5
	Default	[0; 0; 0; 0]	0: No timer assigned
	Level	ENGINEERING	
	Address	827	
	Function	The second group of four digital inputs may be assigned to any of the five timers and the same timer may be assigned to multiple inputs. Select "zero" to avoid delaying the digital inputs. Setting via serial link: see Table 44.	

P228 Timers Assigned to Outputs MDO1÷4

P228	Range	[0; 0; 0; 0] ÷ [5; 5; 5; 5]	0: No timer assigned 1 ÷ 5: T1 ÷ T5
	Default	[0; 0; 0; 0]	0: No timer assigned
	Level	ENGINEERING	
	Address	828	
	Function	The digital outputs may be assigned to any of the five timers and the same timer may be assigned to multiple outputs. Select "zero" to avoid delaying the digital outputs. Setting via serial link: see Table 44.	

P229 Timers Assigned to Virtual Outputs MPL 1÷4

P229	Range	[0; 0; 0; 0] ÷ [5; 5; 5; 5]	0: No timer assigned 1 ÷ 5: T1 ÷ T5
	Default	[0; 0; 0; 0]	0: No timer assigned
	Level	ENGINEERING	
	Address	829	
	Function	The virtual digital outputs may be assigned to any of the five timers and the same timer may be assigned to multiple outputs. Select "zero" to avoid delaying the virtual digital outputs. Setting via serial link: see Table 44.	

24. PID PARAMETERS MENU

24.1. Overview

This menu defines the parameters for the digital PID regulator integrated in the drive.

The PID regulator may be used to control a physical variable which is external to the drive; the variable measure shall be available in the system and must be connected to the “feedback” input.

The PID regulator is used to keep the reference and the control variable constant (feedback); to do so, the PID regulator controls three internal variables, which are described below:

- ✓ Proportional term: this is the variable detecting the instant difference between the reference and the measured value of the physical variable to be controlled (“error “);
- ✓ Integral term: this is the variable keeping track of the “history” of the detected errors (summation of all errors);
- ✓ Derivative term: this is the variable keeping track of the evolution of the error or the controlled variable (difference between two consecutive errors or between two consecutive values of the feedbacked variable);

The weighted summation of these terms represents the output signal of the PID regulator.

The weight of these three terms may be defined by the user with the parameters below.

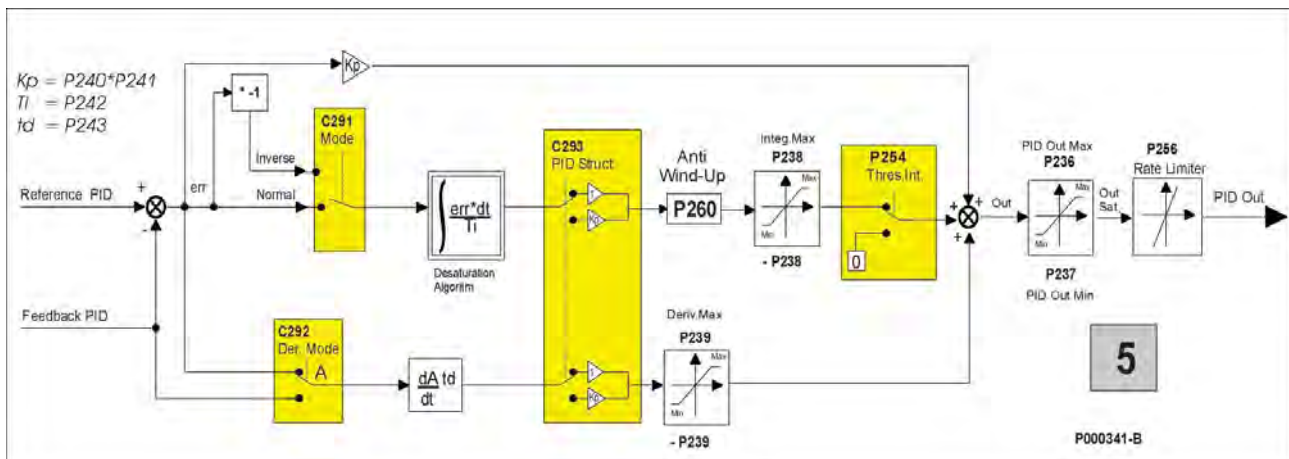

Figure 24: PID Block Diagram



NOTE

In **LOCAL mode**, the PID regulator is disabled if it is used to correct the reference or the voltage values (**C294 = 2: Add Reference** or **C294 = 3: Add Voltage**).



NOTE

In **LOCAL mode**, if the drive reference is the PID output **C294=Reference** and the Type parameter on the Keypad page in Local mode is **P266=Ref.Active+Spd**, the PID reference can be changed by activating the Local mode from the Keypad page. Press the **LOC/REM** key again when the drive is disabled (or the MDI LOC/REM key if it is programmed as a pushbutton: **C180a=Pushbutton**) to disable the PID and to set the speed reference directly from the Keypad page.

24.2. PID Regulator Tuning – Method of Ziegler and Nichols

Tuning a PID regulator consists in selecting and allocating values to PID parameters in order to adjust the operation of the system to the technical requirements of the process and to the equipment restrictions. One of the possible PID tuning procedures is the **Method of Ziegler and Nichols**.

This method implies the following steps:

1. Set the integral action and the derivative action to zero: T_i (P242) = 0, T_d (P243) = 0.
2. Assign very low values to K_p (P240), then apply a little step to the reference signal (setpoint) selected with C285/286/287.
3. Gradually increase the value of K_p until **permanent oscillation** is attained in the PID loop.
4. Tune the parameters for a **P**, **PI** or **PID** regulator based on the table below—where K_{pc} is the value of the proportional gain corresponding to the permanent oscillation (critical gain) and T_c is the period of the permanent oscillation:

	K_p (P240)	T_i (P242)	T_d (P243)
P	$0.5 K_{pc}$		
PI	$0.45 K_{pc}$	$T_c/1.2$	
PID	$0.6 K_{pc}$	$T_c/2$	$T_c/8$

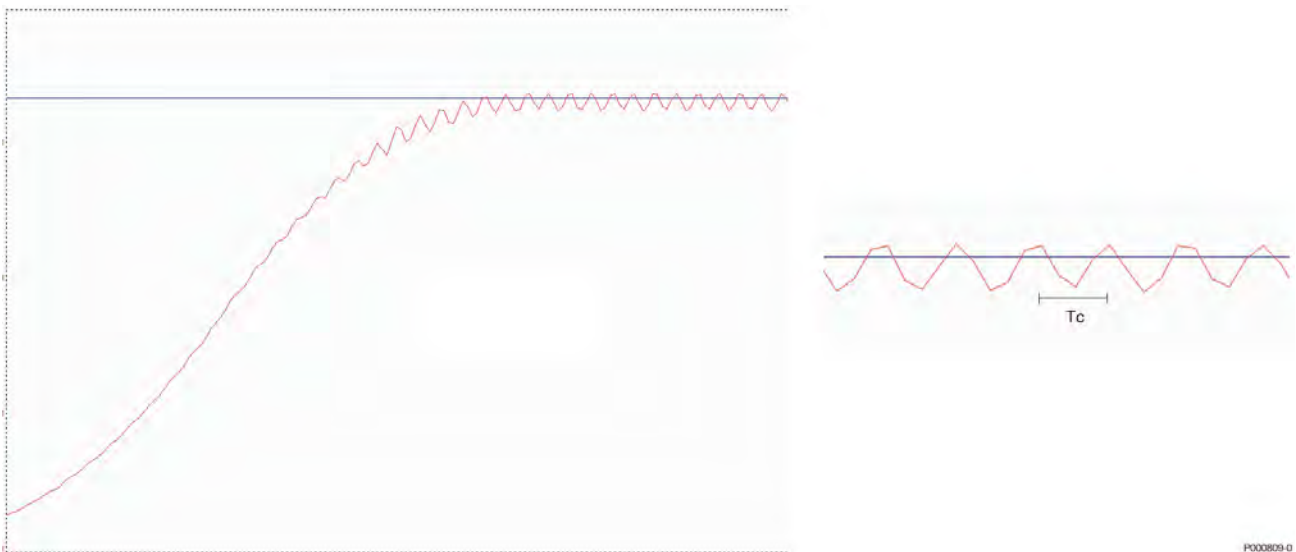

Figure 25: Permanent oscillation with K_{pc} critical gain



Figure 26: Response to a system tuned with the method of Ziegler and Nichols



NOTE

The method of Ziegler and Nichols is not always applicable, because some systems do not produce any oscillations, even in presence of large proportional gains. However, leading a system close to instability can be very dangerous.

24.3. Manual Tuning of the PI Regulator

The PI regulator can be manually tuned when the tuning method of Ziegler and Nichols is not applicable. The sections below cover the following:

- how the transient is affected from the proportional action when the integral action is kept constant in a PI regulator;
- how the transient is affected from the integral action when the proportional action is kept constant in a PI regulator;
- how the transient is affected from the derivative action in a PID regulator.

24.3.1. PROPORTIONAL ACTION (P)

Symbol	Tuning function	Main goal
K_p	An input variance (error) produces an output variance proportional to the variance amplitude	Changes the tuning variable based on the variable being tuned

PI Regulator $T_i = \text{Constant}$	Response to the step	Response time
Small K_p	Overshoot	Longer
Optimum K_p	Optimum	Optimum
Large K_p	Undershoot	Shorter

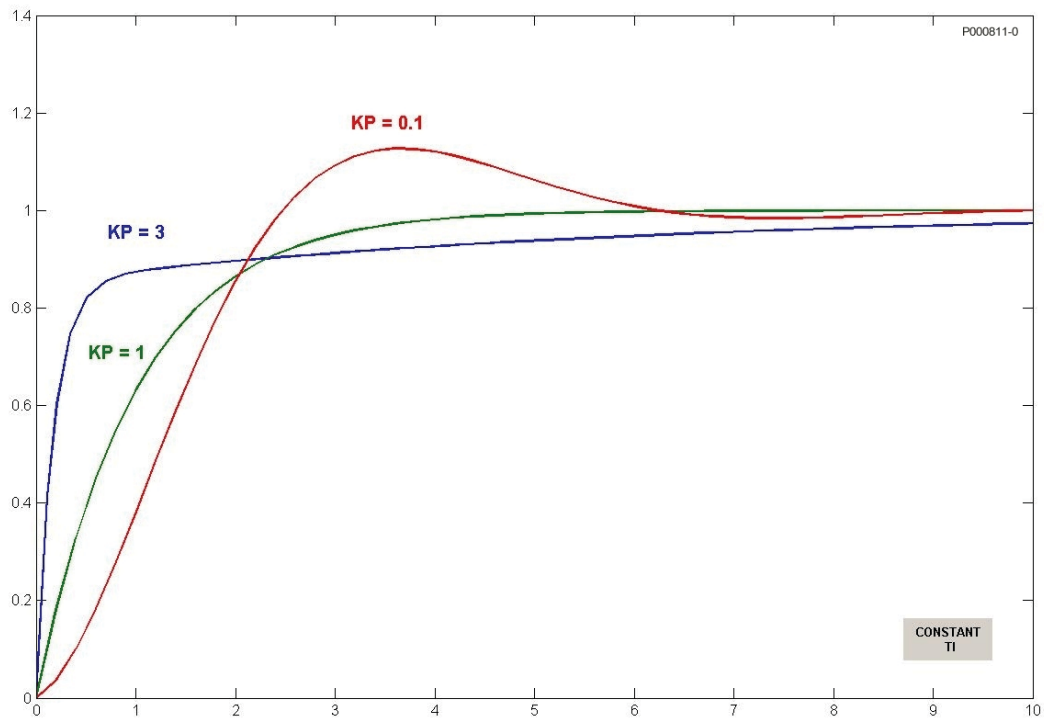

Figure 27: Response to the step based on the value of K_p when T_i is kept constant

When K_p is increased, the error is reduced at constant rate, but the transient can also be adversely affected. Adverse effects can be a longer transient with stronger oscillations due to the damping reduction, or even instability. This is shown in the figure below:

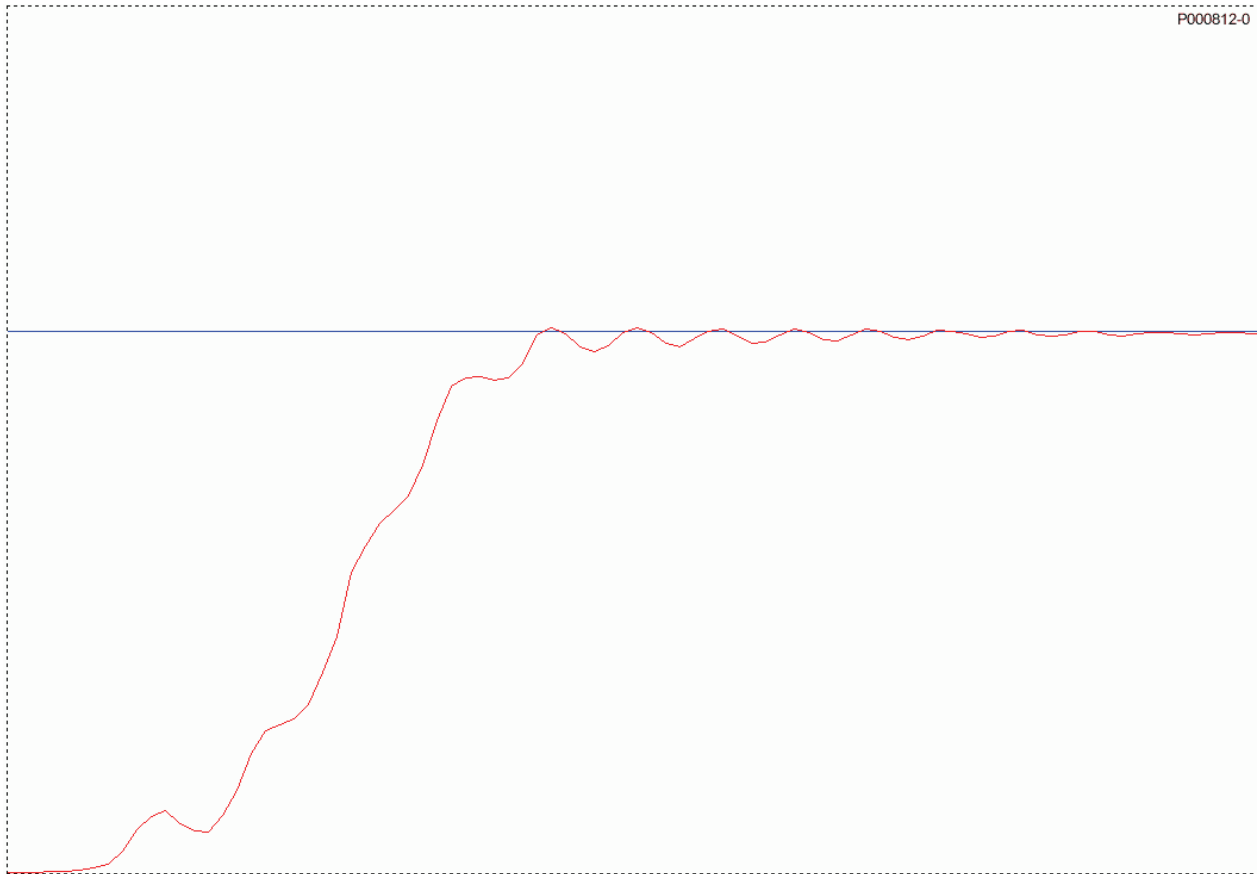

Figure 28: Response to the step when K_p is too large

24.3.2. INTEGRAL ACTION (I)

Symbol	Tuning function	Main goal
T_i	As soon as an input variance occurs (Error), an output variance occurs. The variation rate is proportional to the error magnitude.	Sets the tuning point (eliminates the offset from the proportional action).

PI Regulator	Response to the step	Response time
Small K_p	Overshoot	Shorter
Optimum K_p	Optimum	Optimum
Large K_p	Undershoot	Longer

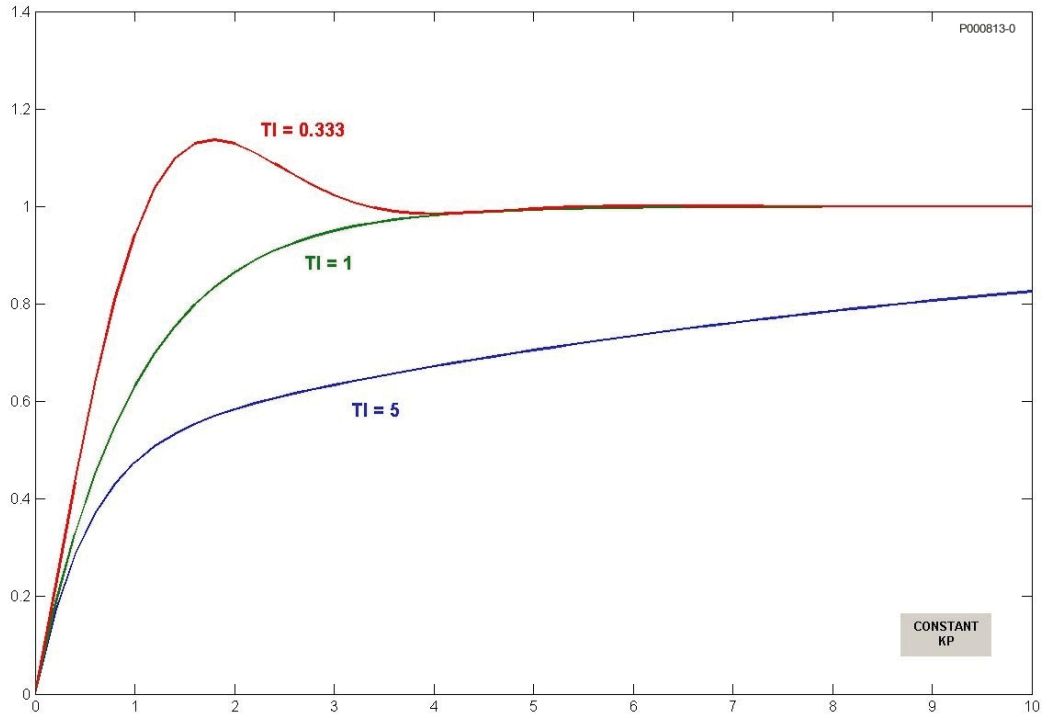

Figure 29: Response to the step based on the value of T_i when K_p is kept constant

The figure below represents the response of the PI regulator when the values for K_p and T_i are lower than the optimum value computed with the *method of Ziegler and Nichols*.

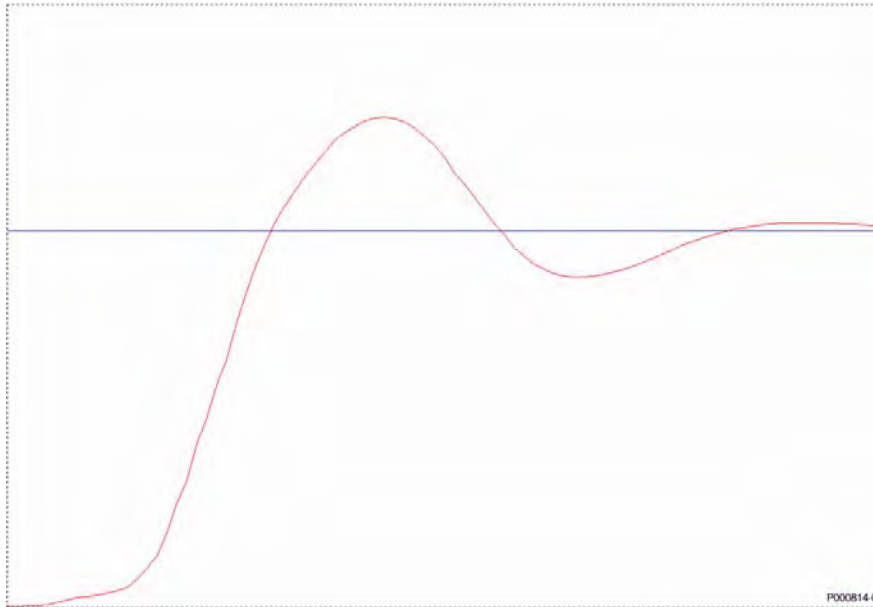

Figure 30: Response to the step when the values of K_p and T_i are too small

24.3.3. DERIVATIVE ACTION (D)

Symbol	Tuning function	Main goal
Td	An input variance (error) generates an output variance proportional to the variance rate	Decreases the response time for the return to the tuning point

The derivative action set with Td increases the stability of the system, thus increasing the transient response. The derivative action tends to get an earlier response, but it increases the system sensitivity to the disturbance overriding the error signal.

24.3.4. TUNING ACTIONS AT CONSTANT SPEED

When the system is operating at constant speed, the system response shall be the most accurate as possible (minimum error) and shall adjust any little reference variations.

When at constant speed, if the system does not promptly respond to little reference variations, a shorter integral time may solve this problem. Otherwise, when little and long-lasting oscillations affect the reference value, setting a longer integral time could be the right solution.

24.4. Anti-windup

The major benefit of the integral action is to ensure null errors at steady speed. However, just like the derivative action, the integral action shall be applied with caution to avoid worse performance.

A case in point is the output saturation occurring at the same time as an excessive integral action. When the output saturates, the control action is limited, so the error is still remarkable. If the error persists, the actuator will saturate, because the longer the time the error persists, the stronger the integral action is; this phenomenon is called "windup". In case of output saturation, the integral term can reach very high values; as a result, the error shall have opposite sign for a long period before exiting from saturation.

The PID regulator of the Penta drive is provided with an Anti-windup function which compensates the effect described above. This Anti-windup action is described below (P=proportional term; I=integral term; D=derivative term).

The output is always calculated as follows:
 $OUT \leftarrow P + I + D$

When output saturation occurs:
 $OUT \leftarrow OUT_{sat}$

The integral term is forced based on the following:
 $I \leftarrow OUT_{sat} - P - D$
 (which is the Anti-windup function).

This prevents the integral term from reaching very high values; the integral term is then kept constantly in line with the saturated output value OUT_{sat} that is present at each moment; any variations of the error (i.e. the P) that allows exiting from saturation have immediate effect to the output, without having to wait for a long time before discharging the integral term itself.

The effect of the Anti-windup can be adjusted with parameter **P260**; if **P260**<1, the effect is reduced and the system is less sensitive to error variations; if **P260**=0, the effect is cancelled.

The value of **P260**=1 is correct for the applications requiring to quickly exit from saturation. On the other hand, reducing **P260** can be useful when output variations are to be avoided for negligible error variations.

24.5. List of Parameters P236 to P260

Table 45: List of Parameters P236 to P260

Parameter	FUNCTION	User Level	Default Values	MODBUS Address
P236	Max. value of PID output	ENGINEERING	+100.00%	836
P237	Min. value of PID output	ENGINEERING	-100.00%	837
P237a	Wake-up Mode	ENGINEERING	0: [Disabled]	858
P237b	Wake-up Level	ENGINEERING	0.00%	859
P238	Max. value of PID integral term	ENGINEERING	+100.00%	838
P239	Max. value of PID derivative term	ENGINEERING	+100.00%	839
P240	PID proportional constant	ENGINEERING	1.000	840
P241	Multiplicative factor of P240	ENGINEERING	0:1.0	841
P242	PID Integral time (multiples of P244)	ENGINEERING	500*Tc (ms)	842
P243	PID Derivative time (multiples of P244)	ENGINEERING	0*Tc (ms)	843
P244	Cycle time of PID regulator: Tc	ENGINEERING	5 ms	844
P245	Min. value of PID reference	ENGINEERING	0.00%	845
P246	Max. value of PID reference	ENGINEERING	+100.00%	846
P247	Min. value of PID feedback	ENGINEERING	0.00%	847
P248	Max. value of PID feedback	ENGINEERING	+100.00%	848
P249	PID reference ramp up time	ENGINEERING	0 s	849
P250	PID reference ramp down time	ENGINEERING	0 s	850
P251	Unit of measure of PID ramp	ENGINEERING	1: [0.1s]	851
P252	PID ramp start rounding off	ENGINEERING	50%	852
P253	PID ramp end rounding off	ENGINEERING	50%	853
P254	Integral term activation threshold	ENGINEERING	0.00%	854
P255	START Disable delay with PID Out= P237	ENGINEERING	0: [Disabled]	855
P256	PID output gradient limit	ENGINEERING	1 ms	856
P257	Gain for PID measure scaling	ENGINEERING	1.000	857
P260	Gain for Anti-windup	ENGINEERING	1.00	860

P236 Max. Value of PID Output

P236	Range	-10000 ÷ +10000	-100.00 ÷ +100.00 %
	Default	+10000	+100.00 %
	Level	ENGINEERING	
	Address	836	
	Function	<p>This is the max. allowable value of PID regulator output. This value is expressed as a percentage; its allocation depends on parameter C294, defining PID action.</p> <p>Example: if C294 = External Out, the PID regulator delivers a reference obtained based on the controlled variable and its setpoint. In this case, the PID output can be brought outside through an analog output. The matching between P236 and the output value (see the ANALOG AND FREQUENCY OUTPUTS MENU) is user-defined.</p> <p>If C294 = Reference, the PID regulator output is the motor speed/torque reference (the system will ignore any other reference source), parameter P236 is a percentage referring to the max. value, considered as an absolute value, between the max. and the min. speed/torque reference of the active motor.</p> <p>If C294 = Add Reference, the percentage in P236 relates to the instant value of the speed/torque reference to be adjusted.</p> <p>If a Frequency control is used, the PID regulator can be used to adjust the drive output voltage; in this case, P236 relates to the instant voltage value (E.g. If a drive delivers 50V and an adjustment of 10% is implemented, the drive will deliver 55V).</p>	

P237 Min. Value of PID Output

P237	Range	-10000 ÷ +10000	-100.00 ÷ +100.00 %
	Default	-10000	-100.00 %
	Level	ENGINEERING	
	Address	837	
	Function	<p>This is the min. allowable value of PID regulator output. For the value percent of P237, see the description of parameter P236.</p>	

P237a Wake-up Mode

P237a	Range	0 ÷ 4	0: Disabled 1: Feedback < P237b 2: Feedback > P237b 3: Error < P237b 4: Error > P237b
	Default	0	0: Disabled
	Level	ENGINEERING	
	Address	858	
	Function	<p>If this parameter is disabled, the PID control re-activates only when the PID output exceeds the value set in parameter P237.</p> <p>If this parameter is enabled, the PID control re-activates when the PID output exceeds the threshold set in parameter P237 and:</p> <p>P237a=1: the Feedback value drops below the level set with P237b; P237a=2: the Feedback value exceeds the level set with P237b; P237a=3: the Error value drops below the level set with P237b; P237a=4: the Error value exceeds the level set with P237b.</p>	

P237b Wake-up Level

P237b	Range	-10000 ÷ +10000	-100.00 ÷ +100.00 %
	Default	0	0.00 %
	Level	ENGINEERING	
	Address	859	
	Function	Level of the Feedback or Error signal allowing re-activating the PID control (see P237a).	

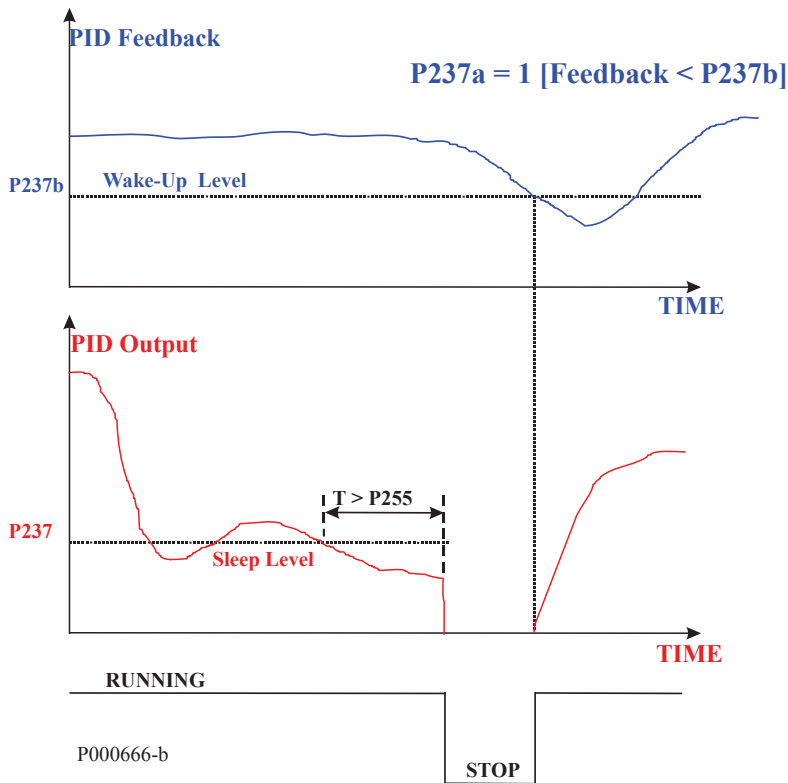

Figure 31: PID Sleep and Wake-up Mode when P237a is set to 1

P238 Max. Value of Integral Term

P238	Range	0 ÷ 10000	-100.00 ÷ +100.00 %
	Default	10000	+100.00 %
	Level	ENGINEERING	
	Address	838	
	Function	This is the max. allowable value of the integral term. It is to be considered <u>as an absolute value</u> ; the output value resulting from the integral term ranges from + P238 to - P238 .	

P239 Max. Value of Derivative Term

P239	Range	0 ÷ 10000	-100.00 ÷ +100.00 %
	Default	10000	+100.00 %
	Level	ENGINEERING	
	Address	839	
	Function	This is the max. allowable value of the derivative term; it is to be considered as an <u>absolute value</u> ; the output value resulting from the derivative term ranges from + P239 to – P239 .	

P240 PID Proportional Constant

P240	Range	0 ÷ 65000	0 ÷ 65.000
	Default	1000	1.000
	Level	ENGINEERING	
	Address	840	
	Function	This is the value of the proportional coefficient. The PID regulator will use Kp resulting from the product of P240 multiplied by P241 (multiplicative factor).	

P241 Multiplicative Factor of P240

P241	Range	0÷2	0: 1.0 1: 10.0 2: 100.0
	Default	0	0: 1.0
	Level	ENGINEERING	
	Address	841	
	Function	Multiplicative factor of the proportional coefficient. This is used to obtain a wider range for the proportional coefficient used in PID regulator and ranging from 0.000 to 6500.0. Supposing that the default values are used for P240 and P241 , the proportional coefficient used in the PID regulator is unitary: in case an error of 1% occurs between the reference and the controlled variable, the proportional term, representing one of the three values of the regulator output, will be 1%.	

P242 PID Integral Time (Multiples of P244)

P242	Range	0 ÷ 65000	0: Disabled ÷ 65000 * Tc (ms)
	Default	500	500* Tc (ms)
	Level	ENGINEERING	
	Address	842	
	Function	Ti constant dividing the integral term of PID regulator: $K_i = 1/T_i = 1/(P_{242} * T_s)$ It is expressed in <u>sampling time units Ts</u> (see P244). If this parameter is set to zero, the integral action is cancelled.	

P243 PID Derivative Time (Multiples of P244)

P243	Range	0 ÷ 65000	0 ÷ 65.000 * Tc (ms)
	Default	0	0*Tc (ms)
	Level	ENGINEERING	
	Address	843	
	Function	Constant multiplying the derivative term of PID regulator. If this parameter is set to zero, the derivative action is disabled.	

P244 Cycle Time of PID Regulator: Tc

P244	Range	5 ÷ 65000	0 ÷ 65000 ms
	Default	5	5 ms
	Level	ENGINEERING	
	Address	844	
	Function	This parameter sets the cycle time of PID regulator. It is expressed in ms (multiples of 5 only). Example: if P244 = 1000 ms, the PID regulator cycle will be executed every second, and the output will be refreshed every second as well.	

P245 Min. Value of PID Reference

P245	Range	-20000 ÷ +20000	±200.00%
	Default	0	0.00%
	Level	ENGINEERING	
	Address	845	
	Function	This parameter defines the min. allowable value of the PID reference. The PID references are to be considered as percentage values. If analog references are selected, P245 relates to the minimum value of the selected analog input. Example: Select AIN1 analog input as the PID reference and suppose that its max. and min. values are +10V and -10V respectively. If P245 is -50%, this means that the PID reference will be saturated at -50% for voltage values lower than -5V.	

P246 Max. Value of PID Reference

P246	Range	-20000 ÷ +20000	±200.00%
	Default	+10000	+100.00%
	Level	ENGINEERING	
	Address	846	
	Function	This parameter defines the max. allowable value of the PID reference. See the description of P245 .	

P247 Min. Value of PID Feedback

P247	Range	-20000 ÷ +20000	±200.00%
	Default	0	0.00%
	Level	ENGINEERING	
	Address	847	
	Function	This parameter defines the min. allowable value of the PID feedback. See the description of P245 .	

P248 Max. Value of PID Feedback

P248	Range	-20000 ÷ +20000	±200.00%
	Default	+10000	+100.00%
	Level	ENGINEERING	
	Address	848	
	Function	This parameter defines the max. allowable value of the PID feedback. See the description of P245 .	

P249 PID Reference Ramp Up Time

P249	Range	0 ÷ 32700	Function of P251
	Default	0	0 s
	Level	ENGINEERING	
	Address	849	
	Function	This parameter defines the ramp up time of the PID regulator reference from 0% to the max. allowable absolute value (max. { P245 , P246 }).	

P250 PID Reference Ramp Down Time

P250	Range	0 ÷ 32700	Function of P251
	Default	0	0 s
	Level	ENGINEERING	
	Address	850	
	Function	This parameter defines the ramp down time of the PID regulator reference, from max. allowable value (max. { P245 , P246 }) to 0%.	

P251 Unit of measure of PID Ramp

P251	Range	0 ÷ 3	0: 0.01 s 1: 0.1 s 2: 1.0 s 3: 10.0 s
	Default	1	1: 0.10 s
	Level	ENGINEERING	
	Address	851	
	Function	This parameter defines the unit of measure for the PID reference ramp times. It defines the unit of measure for the time of the third ramp of the PID reference P249 and P250 , so that the allowable range becomes 0s – 327000s.	

Example:

P251		Range P249 – P250	
Value	Coding	Min.	Max.
0	0.01 s	0	327.00 s
1	0.1s	0	3270.0 s
2	1.0 s	0	32700 s
3	10.0 s	0	327000 s



NOTE

Factory-setting: the PID reference ramp is zero; if a given ramp time is set up, the ramp will be rounded off (50% at the beginning and at the end of the ramp). See parameters **P252** and **P253**.

P252 PID Ramp Start Rounding Off

P252	Range	0 ÷ 100	0 % ÷ 100%
	Default	50	50%
	Level	ENGINEERING	
	Address	852	
	Function	This parameter sets the time period of the rounding off applied to the first stage of the ramps. It is expressed as a percentage of the ramp up/down time. Example: ramp up of 5sec.: P252 = 50% means that the speed reference is limited in acceleration for the first 2.5 sec of the ramp up.	



NOTE When **P252** is used, the preset ramp time is increased by $(\mathbf{P252}\%)/2$.

P253 PID Ramp End Rounding Off

P253	Range	0 ÷ 100	0 % ÷ 100%
	Default	50	50%
	Level	ENGINEERING	
	Address	853	
	Function	As P252 , but P253 sets the rounding off applied at the end of the ramps.	



NOTE When **P253** is used, the preset ramp time is increased by $(\mathbf{P253}\%)/2$.

P254 Integral Term Activation Threshold

P254	Range	0.0 ÷ 5000	0.0 % ÷ 500.0%
	Default	0	0.0 %
	Level	ENGINEERING	
	Address	854	
	Function	This parameter sets a threshold value below which the integrator is kept to zero. It has effect only when the PID regulator is used as a reference corrector or generator. In this case, the threshold percentage value refers to the max. speed (or torque) absolute value set for the active motor. The integral term is not calculated when the speed (or torque) percentage value expressed as an absolute value is lower than the value set in P254 . If P254 is set to zero, the integrator is always activated.	

P255 START Disable Delay with PID Out=P237

P255	Range	0 ÷ 60000	0: Disabled 1 ÷ 60000 s
	Default	0	0: Disabled
	Level	ENGINEERING	
	Address	855	
	Function	<p>This parameter sets the max. time for the drive operation when the PID regulator output continuously operates at its min. value (P237).</p> <p>If this is true for a time equal to the time set in P255, the drive is automatically put on stand-by until</p> <p>1) the PID output value exceeds the min. value (if P237a=Disabled);</p> <p>2) the Feedback or the Error drops below the Wake-up level in P237b (if P237a=1 or =3 respectively);</p> <p>3) when the Feedback or the Error exceeds the Wake-up level in P237b (if P237a=2 or =4 respectively).</p> <p>If C294 is set as External Out or P255 is set to zero, this function is disabled.</p>	

P256 PID Output Gradient Limit

P256	Range	1 ÷ 65000	1 ÷ 65000msec
	Default	1	1msec
	Level	ENGINEERING	
	Address	856	
	Function	<p>This parameter limits the max. acceleration for the PID regulator output.</p> <p>The max. acceleration for the PID regulator output is equal to 100% / P256 [%/msec].</p>	

P257 Gain for PID Measure Scaling

P257	Range	0 ÷ 65535	0.000 ÷ 65.535
	Default	1	1.000
	Level	ENGINEERING	
	Address	857	
	Function	<p>Gain for the scaling of PID measures M023 ÷ M024.</p> <p>This gain has effect only on the measures above. It does not affect the PID operation.</p> <p>This parameter allows scaling if you want to display PID measures with a different unit of measure:</p> <p>M023 = M020 * P257</p> <p>M024 = M021 * P257</p>	

P260 Anti Wind-Up Gain

P260	Range	0 ÷ 100	0.00 ÷ 1.00
	Default	100	1.00
	Level	ENGINEERING	
	Address	860	
	Function	<p>Value of the Anti Wind-Up coefficient that freezes the integral term of the PID when its output is being saturated (see Anti-windup).</p> <p>When leaving P260=1.00, Anti Wind-Up is complete ($I \leftarrow OUT_{sat} - P - D$).</p> <p>If P260=0.00, Anti Wind-Up is inhibited (the integral term reaches the value of $\pm P238$ based on the error sign).</p> <p>Intermediate values for P260 give intermediate effects.</p>	

25. PID2 PARAMETERS MENU

25.1. Overview

This menu defines the parameters of the digital regulator PID2 as well as the parameters used in 2-zone mode.

To activate the PID2 regulator, set **C291a = 7: 2 PID** (PID CONFIGURATION MENU).

Once activated, the PID2 regulator has the same functionality and operates in line with the standard PID (PID PARAMETERS MENU). The output of the standard PID regulator is algebraically summed with the output of the PID2 regulator.

Add "200" to the parameter codes pertaining to the standard PID to obtain the relevant parameter codes for PID2. Example: **P236** for standard PID corresponds to **P436** for PID2.

To enable the 2-zone mode, set **C291a = 5: 2-Zone MIN** or **6: 2-Zone MAX** (PID CONFIGURATION MENU).

Once the 2-zone mode is enabled, the standard PID regulator operates on the system with the larger error (minimum feedback in respect to its reference, **2-Zone MIN**) or with the smaller error (maximum feedback in respect to its reference, **2-Zone MAX**).

In 2-zone mode, parameters **P236..P260** pertain to the system where the error results from the reference selected with **C285** and from the feedback selected with **C288**, whilst parameters **P436..P460** pertain to the system where the error results from the reference selected with **C286** and from the feedback selected with **C289**.



NOTE The PID2 regulator is disabled when operating in 2-zone mode.

Please refer to the block diagram in Figure 69.

25.2. List of Parameters P436 to P460

Table 46: List of Parameters P436 to P460

Parameter	FUNCTION	User Level	DEFAULT VALUES	MODBUS Address
P436	Max. value of PID2 output	ENGINEERING	+100.00%	1346
P437	Min. value of PID2 output	ENGINEERING	-100.00%	1347
P437a	Wake-up Mode	ENGINEERING	0: [Disabled]	1282
P437b	Wake-up Level	ENGINEERING	0.00%	1283
P438	Max. value of PID2 integral term	ENGINEERING	+100.00%	1348
P439	Max. value of PID2 derivative term	ENGINEERING	+100.00%	1349
P440	PID2 proportional constant	ENGINEERING	1.000	1350
P441	Multiplicative factor of P440	ENGINEERING	0:1.0	1351
P442	PID2 Integral time (multiples of P444)	ENGINEERING	500*Tc (ms)	1352
P443	PID2 Derivative time (multiples of P444)	ENGINEERING	0*Tc (ms)	1353
P444	Cycle time of PID2 regulator: Tc	ENGINEERING	5 ms	1354
P445	Min. allowable value of PID2 reference	ENGINEERING	0.00%	1355
P446	Max. allowable value of PID2 reference	ENGINEERING	+100.00%	1356
P447	Min. allowable value of PID2 feedback	ENGINEERING	0.00%	1357
P448	Max. allowable value of PID2 feedback	ENGINEERING	+100.00%	1358
P449	PID2 reference ramp up time	ENGINEERING	0 s	1359
P450	PID2 reference ramp down time	ENGINEERING	0 s	1360
P451	Unit of measure of PID2 ramp	ENGINEERING	1: [0.1s]	1361
P452	PID2 ramp start rounding off	ENGINEERING	50%	1362
P453	PID2 ramp end rounding off	ENGINEERING	50%	1363
P454	Integral term activation threshold	ENGINEERING	0.00%	1364
P455	START Disable delay with PID2 output= P437	ENGINEERING	0: [Disabled]	1284
P456	PID2 output gradient limit	ENGINEERING	1 ms	1368
P457	Gain for PID2 measure scaling	ENGINEERING	1.000	1369
P460	Gain for Anti Wind-Up	ENGINEERING	1.00	1370



NOTE Parameters **P437a**, **P437b** and **P455** are overridden if the Two PIDs mode is selected with “summed outputs” (**C291a = 7: 2 PID** and **C171a = 0: Disabled**).



NOTE For a detailed description of these parameters, see List of Parameters P236 to P260 related to PID.

26. DIGITAL OUTPUTS MENU

26.1. Overview

The Digital Outputs menu includes the parameters allowing configuring the drive digital outputs (MDO1, MDO2, MDO3 and MDO4).



NOTE

The Digital Outputs menu may be accessed only if the user level is **ADVANCED** or **ENGINEERING**.



NOTE

For a detailed hardware description of the digital outputs, please refer to the Sinus Penta's Installation Guide.



NOTE

MDO1 digital output can be programmed only if the frequency output is not set up (**P200** = Disable; see the **ANALOG AND FREQUENCY OUTPUTS MENU**).



NOTE

XMDI digital outputs (values from 13 to 20 in the parameters relating to the control functions) can be set up only after setting XMDI/O in parameter **R023**.

26.1.1. FACTORY SETTINGS

The factory settings are as follows:

MDO1 is a zero speed relay (it energizes when a preset threshold is exceeded).

MDO2 controls an electromechanical brake used for hoisting applications (it energizes to release the brake).

MDO3 de-energizes (fail-safe logic) in case of "Inverter Alarm".

MDO4 energizes when the drive is running and is enabling the power stage ("Inverter Run OK" condition).

26.1.2. STRUCTURE OF THE DIGITAL OUTPUTS

A digital output is composed of two logic blocks allowing data processing before actuating the actual digital output. Block 2 depends on the settings in parameters **P277a** (**P286a**, **P295a**, **P304a**).

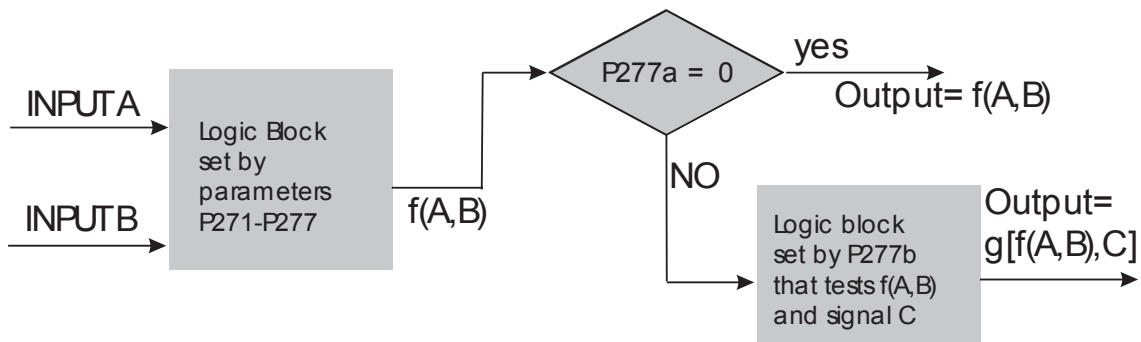

P000659-b

Figure 32: MDO block-diagram

Operating modes set in MDO1 (2,3,4) Digital Output: P270, (P279, P288, P297)

The user can select one of the following operating modes:

Table 47: Digital Output Mode

DISABLE	The selected digital output is disabled.
DIGITAL	The digital output depends on a selected digital signal and on the logic output function (True/False). See Examples 1 and 2.
DOUBLE DIGITAL	The digital output depends on 2 selected digital signals, on the logic function calculating the output value and on the logic output function (True/False).
ANALOG	The digital output depends on a selected analog variable, which is tested through Test A obtaining one digital signal; starting from its value, the selected logic function calculates the True/False end value. See Example 3.
DOUBLE ANALOG	The digital outputs depends on 2 selected analog variables: Test A is performed for variable A, whilst Test B is performed for variable B, thus obtaining 2 digital signals; starting from their value, the selected logic function calculates the output value, whereas the logic output function True/False calculates the end value.
DOUBLE FULL	As DOUBLE ANALOG or DOUBLE DIGITAL mode, but both digital signals and analog variables can be selected. If you select a digital signal, its value (TRUE or FALSE) is used to calculate the selected logic function. If you select an analog variable, the test selected for this variable is performed, and its result (TRUE or FALSE) is used to calculate the selected logic function.
BRAKE (*)	As ABS BRAKE below, although the selected variables are not expressed as absolute values, but depend on the selected tests.
ABS BRAKE (*)	The ABS BRAKE mode allows controlling the electromechanical brake of a motor used for hoisting applications. The ABS BRAKE mode is applied by selecting the measured (or estimated) speed value [A71] as the first variable, and the output torque [A81] as the second variable. Variables are considered as absolute values. See Example 4: Digital output for electromechanical brake for hoisting applications (programming example related to MDO3 digital output).
ABS LIFT (*)	As ABS BRAKE, but the brake unlocks (digital output open) when a given torque value is attained, which is automatically determined based on the last torque value required in the previous stroke.
PWM MODE	The PWM mode may be selected for digital outputs MDO1 and MDO2 only (it cannot be selected for relay digital outputs MDO3 and MDO4). The digital output becomes a low-frequency PWM output with a duty-cycle proportional to the value of the selected analog output. See Example 5: Using the PWM Function.

(*) The activation and deactivation of the outputs programmed as **BRAKE**, **ABS BRAKE** and **ABS LIFT** is affected also by other conditions depending on the drive status. Namely:

Activation	Conditions to be considered in logic AND with the following programmed functions: <ul style="list-style-type: none"> • Drive accelerating and (AND) with absolute value speed >1 rpm or (OR) drive in pretensioning stage (see BRIDGE CRANE MENU). • Drive running, no alarm triggered
Deactivation	Conditions to be considered in logic OR with the following programmed functions: <ul style="list-style-type: none"> • Drive not running or locked due to an alarm condition • Drive in tracking error mode (see ENCODER/FREQUENCY INPUTS MENU), unless parameter C303 is set to NO (see BRIDGE CRANE MENU).



CAUTION

The digital outputs programmed as **BRAKE**, **ABS BRAKE** or **ABS LIFT** are inactive in a drive configured in slave mode (torque control).
In a master/slave system, both electromechanical brakes must be controlled by the master.

Variable A Selected for MDO1 (2,3,4): P271, (P280, P289, P298)

This selects the digital signal or the analog variable used for Test A (set with **P273/P282/P291/P300**). The whole list of the selectable items and their description appears at the end of this section (see Table 48). If a digital signal is selected, Test A is not performed: therefore, the comparison value for Test A (set with **P275/P284/P293/P302**) has no meaning.



NOTE

This parameter can be accessed only if the operating mode of the digital output concerned is other than zero. Example: MDO1 **P270**≠0.

Variable B selected for MDO1 (2,3,4): P272, (P281, P290, P299)

This selects a different digital signal or the analog variable used for Test B (set with **P274/P283/P292/P301**). The whole list of the selectable items and their description appears at the end of this section (see Table 48). If a digital signal is selected, Test B is not performed: therefore, the comparison value for Test B (set with **P276/P285/P294/P303**) has no meaning.



NOTE

Parameter **P272** cannot be accessed when the digital output operating mode is 1: DIGITAL or 3: ANALOG.

Example: MDO1 **P270**=1 OR **P270**=3.

Table 48: List of the selectable digital signals and analog variables

Selectable digital signals (BOOLEAN):

Selectable Value	Description
D0: Disabled	Always FALSE: 0
D1: Inverter Run Ok	Drive running (no standby)
D2: Inverter Ok On	Inverter ok: no alarms tripped
D3: Inverter Alarm	Drive alarm tripped
D4: Inverter Run Alarm	Drive KO: alarm tripped when the drive is running
D5: Fwd Running	Speed (measured or estimated) higher than +0.5 rpm
D6: Rev Running	Speed (measured or estimated) lower than -0.5 rpm
D7: Limiting Motor	Drive in limiting mode operating as a motor
D8: Limiting Generator	Drive in limiting mode operating as a generator
D9: Limiting	Drive in limiting mode (generator or motor)
D10: Precharge Ok	Capacitor Precharge relay closure and command return test
D11: PID Out Max	PID output max. saturation
D12: PID Out Min	PID output min. saturation
D13: MDI 1	Selected MDI1 digital input (remote OR physical)
D14: MDI 2	Selected MDI2 digital input (remote OR physical)
D15: MDI 3	Selected MDI3 digital input (remote OR physical)
D16: MDI 4	Selected MDI4 digital input (remote OR physical)
D17: MDI 5	Selected MDI5 digital input (remote OR physical)
D18: MDI 6	Selected MDI6 digital input (remote OR physical)
D19: MDI 7	Selected MDI7 digital input (remote OR physical)
D20: MDI 8	Selected MDI8 digital input (remote OR physical)
D21: Enable	ENABLE function (remote AND physical)
D22: Enable SW	ENABLE-SW function (remote AND physical)
D23: MDI 1 Delayed	MDI1 Digital input (remote OR physical) DELAYED by MDI timers
D24: MDI 2 Delayed	MDI2 Digital input (remote OR physical) DELAYED by MDI timers
D25: MDI 3 Delayed	MDI3 Digital input (remote OR physical) DELAYED by MDI timers
D26: MDI 4 Delayed	MDI4 Digital input (remote OR physical) DELAYED by MDI timers
D27: MDI 5 Delayed	MDI5 Digital input (remote OR physical) DELAYED by MDI timers
D28: MDI 6 Delayed	MDI6 Digital input (remote OR physical) DELAYED by MDI timers
D29: MDI 7 Delayed	MDI7 Digital input (remote OR physical) DELAYED by MDI timers
D30: MDI 8 Delayed	MDI8 Digital input (remote OR physical) DELAYED by MDI timers



Selectable Value	Description
D31: Enable Delayed	ENABLE function (remote AND physical) DELAYED by MDI timers
D32: Tracking Error	Speed tracking error: $ \text{SetPoint} - \text{Measure} > \text{Error_Par}$

Selectable Value	Description
D33: Fan Fault	Fault of the cooling fan
D34: Field Bus Cmd1	Command 1 from fieldbus
D35: Field Bus Cmd2	Command 2 from fieldbus
D36: Field Bus Cmd3	Command 3 from fieldbus
D37: Field Bus Cmd4	Command 4 from fieldbus
D38: Fire Mode	Fire Mode function
D39: Local	LOCAL Mode
D40: Speed Ok	Constant speed reference reached
D41: Fan ON	Fan activation command
D42: XMDI1	XMDI1 Auxiliary digital input
D43: XMDI2	XMDI2 Auxiliary digital input
D44: XMDI3	XMDI3 Auxiliary digital input
D45: XMDI4	XMDI4 Auxiliary digital input
D46: XMDI5	XMDI5 Auxiliary digital input
D47: XMDI6	XMDI6 Auxiliary digital input
D48: XMDI7	XMDI7 Auxiliary digital input
D49: XMDI8	XMDI8 Auxiliary digital input
D50: MPL1 Delayed	Virtual digital input resulting from MPL1 output DELAYED from MPL Timers
D51: MPL2 Delayed	Virtual digital input resulting from MPL2 output DELAYED from MPL Timers
D52: MPL3 Delayed	Virtual digital input resulting from MPL3 output DELAYED from MPL Timers
D53: MPL4 Delayed	Virtual digital input resulting from MPL4 output DELAYED from MPL Timers
D54: OTM Elapsed	Maintenance Operation Time elapsed
D55: STM Elapsed	Maintenance Supply Time elapsed
D56: MDO1 Delayed	Virtual digital input resulting from MDO1 output DELAYED from MDO Timers
D57: MDO2 Delayed	Virtual digital input resulting from MDO2 output DELAYED from MDO Timers
D58: MDO3 Delayed	Virtual digital input resulting from MDO3 output DELAYED from MDO Timers
D59: MDO4 Delayed	Virtual digital input resulting from MDO4 output DELAYED from MDO Timers
D60: TFL1	Timed flag TFL1
D61: TFL2	Timed flag TFL2
D62: TFL3	Timed flag TFL3
D63: TFL4	Timed flag TFL4
D64: NTC Fault	NTC Fault (heatsink temperature measurement)
D65: Cumulative Warning	Logic OR of W40 (FAN FAULT), W50 (NTC FAULT), W48 (OT TIME OVER), W49 (ST TIME OVER)
D66: Dec to Stop	Deceleration due to START opening or STOP activation
D67: Reserved	
D68: Accelerating	Motor accelerating
D69: Decelerating	Motor decelerating
D70-D73: Reserved	
D74: kWh pulse	One pulse 500 ms long each kWh
D75-D79: Reserved	

Selectable analog variables:

Selectable Value	Full-scale Value	Kri	Description
A00: GROUND			Analog 0 Volt
A01: Speed	10000 rpm	1	Motor speed
A02: Spd REF.	10000 rpm	1	Speed reference at constant speed
A03: RampOut	10000 rpm	1	Speed reference when ramps are over
A04: MotFreq	1000.0 Hz	10	Frequency produced by the drive
A05: MotCurr	5000.0 A	10	Current RMS
A06: OutVolt	2000.0 V	10	Output voltage RMS
A07: Out Pow	1000.0 kW	10	Output power
A08: DC Vbus	2000.0 V	10	DC-link voltage
A09: Torq.REF	100.00 %	100	Torque reference at constant speed
A10: Torq.DEM	100.00 %	100	Torque demand
A11: Torq.OUT	100.00 %	100	Estimation of the torque output
A12: Torq.LIM	100.00 %	100	Torque limit setpoint
A13: PID REF	100.00 %	100	PID reference at constant speed
A14: PID RMP	100.00 %	100	PID reference when ramps are over
A15: PID Err	100.00 %	100	Error between PID reference and PID feedback
A16: PID Fbk	100.00 %	100	PID feedback
A17: PID Out	100.00 %	100	PID output
A18: REF	100.00 %	100	Analog input REF
A19: AIN1	100.00 %	100	Analog input AIN1
A20: AIN2/Pt	100.00 %	100	Analog input AIN2/PTC
A21: Encln	10000 rpm	1	Speed read from encoder and used as a reference
A22: PulseIn	100.00 kHz	100	Frequency input
A23: Flux REF	1.0000 Wb	10000	Flux reference at constant speed
A24: Flux	1.0000 Wb	10000	Active flux reference
A25: Iq REF	5000.0 A	10	Current reference over axis q
A26: Id REF	5000.0 A	10	Current reference over axis d
A27: Iq	5000.0 A	10	Current measure over axis q
A28: Id	5000.0 A	10	Current measure over axis d
A29: Volt Vq	2000.0 V	10	Voltage over axis q
A30: Volt Vd	2000.0 V	10	Voltage over axis d
A31: Cosine	100.00 %	100	Waveform: Cosine
A32: Sine	100.00 %	100	Waveform: Sine
A33: Angle	100.00 %	100	Electric angle of delivered Vu
A34: +10V			Analog +10 Volt
A35: -10V			Analog -10 Volt
A36: Flux Current	5000.0A	10	Flux current
A37: SqrWave	100.00 %	100	Square wave
A38: Saw Wave	100.00 %	100	Saw wave
A39: HtsTemp.	100.00 °C	100	Heatsink temperature
A40: AmbTemp.	100.00 °C	100	Ambient temperature
A41 ÷ A49: Reserved			
A50: PT100_1	320.00 °C	100	PT100 channel 1
A51: PT100_2	320.00 °C	100	PT100 channel 2
A52: PT100_3	320.00 °C	100	PT100 channel 3
A53: PT100_4	320.00 °C	100	PT100 channel 4
A54: I2t%	100.00 %	100	Motor thermal capacity
A55: XAIN4	100.00 %	100	XAIN4 analog input
A56: XAIN5	100.00 %	100	XAIN5 analog input
A57: OT Counter	320000h	1	Maintenance Operation Time counter
A58: ST Counter	320000h	1	Maintenance Supply Time counter
A59: PID2 REF	100.00 %	100	PID2 reference at constant speed
A60: PID2 RMP	100.00 %	100	PID2 reference when ramps are over
A61: PID2 Fbk	100.00 %	100	Error between PID2 reference and PID2 feedback
A62: PID2 Err	100.00 %	100	PID2 feedback
A63: PID2 Out	100.00 %	100	PID2 output
A64: Torque Demand %	100.00 %	100	Torque demand (percentage)
A65: Actual Current Iv	5000.0A	10	Output current Iv
A66 ÷ A69: Reserved			

Minimum value = $-3.2 \cdot \text{Full-scale value}$
Maximum value = $3.2 \cdot \text{Full-scale value}$
MODBUS value = $\text{Parameter value} \cdot \text{Kri}$

Testing Variable A for MDO1 (2,3,4): P273, (P282, P291, P300)

If an analog variable is selected, a logic TEST is performed to obtain a TRUE/FALSE Boolean signal. Seven different tests are available, that can be performed for selected variable A and its comparing value A:

Table 49: Test functions

GREATER THAN	Selected variable > comparing value
GREATER THAN/EQUAL TO	Selected variable ≥ comparing value
LOWER	Selected variable < comparing value
LOWER THAN/EQUAL TO	Selected variable ≤ comparing value
ABS, GREATER THAN	Absolute value (selected variable) > comparing value
ABS, GREATER THAN/EQUAL TO	Absolute value (selected variable) ≥ comparing value
ABS, LOWER	Absolute value (selected variable) < comparing value
ABS, LOWER THAN/EQUAL TO	Absolute value (selected variable) ≤ comparing value



NOTE

This parameter can be accessed only if the operating mode of the selected digital output is > 2. Example: MDO1 **P270**>2.

Testing Variable B for MDO1 (2,3,4): P274, (P283, P292, P301)

If an analog variable is selected, a logic TEST is performed to obtain a TRUE/FALSE Boolean signal. Seven different tests are available, that can be performed for selected variable B and its comparing value B (see Table 49).



NOTE

This parameter can be accessed only if the operating mode of the selected digital output is > 2 and < 9. Example: MDO1 2<**P270**<9.

Reference threshold for P271 (P280, P289, P298) in MDO1: P275, (P284, P293, P302)

This defines the comparing value of Test A with the first selected variable.



NOTE

This parameter can be accessed only if the operating mode of the selected digital output is > 2. Example: MDO1 **P270**>2.

Reference threshold for P272 (P281, P290, P299) in MDO2 (3,4): P276, (P285, P294, P303)

This defines the comparing value of Test B with the first selected variable.



NOTE

This parameter can be accessed only if the operating mode of the selected digital output is > 2. Example: MDO1 **P270**>2.

MDO1 (2, 3, 4): Function Applied to the Result of Tests A and B: P277, (P286, P295, P304)

A logic function is applied to the two Boolean signals obtained in order to obtain the output TRUE/FALSE Boolean signal.
Six different tests may be performed for variable (A) using the comparing value and variable (B).

(A) OR (B): The selected digital output is enabled when at least one of the two conditions below is true (this function also allows enabling the selected digital input based on one test only).

(A) OR (B)		
Test A	Test B	Output
0	0	0
1	0	1
0	1	1
1	1	1

- (A) SET (B) RESET Rising Edge**
- (A) RESET (B) SET Rising Edge**
- (A) SET (B) RESET Falling Edge**
- (A) RESET (B) SET Falling Edge**

The selected digital output is activated as the output of a Flip Flop Set Reset whose inputs are signal A and signal B. This function can be used in case of hysteresis.

The status of the input (Q_n) depends on the previous value (Q_{n-1}) and on the result of the two tests.

Signals A and B are considered only when passing from 0→1 (Rising Edge) or 1→0 (Falling Edge). Signal A and signal B may be used both as Set and Reset command.

Example: Suppose that the output enables only when the motor speed exceeds 50rpm and disables when the motor speed drops below 5 rpm. To do so, assign the first condition to Test A, representing the Set command for Flip Flop (**P271** = Motor Speed, **P273** >, **P275** = 50rpm), and assign the second condition to Test B, representing the Reset command (**P272** = Motor Speed, **P274** <=, **P276** = 5rpm). A more detailed example is given at the end of this section.

(A) SET (B) RESET Rising Edge		
Test A (Set)	Test B (Reset)	Q _n
0→1	X	1
X	0→1	0
In any other case		Q_{n-1}

(A) RESET (B) SET Rising Edge		
Test A (Reset)	Test B (Set)	Q _n
0→1	X	0
X	0→1	1
In any other case		Q_{n-1}

(A) SET (B) RESET Falling Edge		
Test A (Set)	Test B (Reset)	Q _n
1→0	X	1
X	1→0	0
In any other case		Q_{n-1}

(A) RESET (B) SET Falling Edge		
Test A (Reset)	Test B (Set)	Q _n
1→0	X	0
X	1→0	1
In any other case		Q_{n-1}



(A) AND (B): The selected digital output enables when both conditions are true.

(A) AND (B)		
Test A	Test B	Output
0	0	0
1	0	0
0	1	0
1	1	1

(A) XOR (B): The selected digital output enables when either one condition or the other is true (but not when both conditions are true at a time).

(A) XOR (B)		
Test A	Test B	Output
0	0	0
1	0	1
0	1	1
1	1	0

(A) NOR (B): The selected digital output enables when no condition is true. The NOR function between two variables corresponds to the AND of the same false variables, i.e. $(A)NOR (B) = (/A) AND (/B)$.

(A) NOR (B)		
Test A	Test B	Output
0	0	1
1	0	0
0	1	0
1	1	0

(A) NAND (B): The selected digital output enables when no condition is true or when only one of the two conditions is true. The NAND function between two variables corresponds to the OR of the same false variables, i.e. $(A)NAND (B) = (/A) OR (/B)$.

(A) NAND (B)		
Test 1	Test 2	Output
0	0	1
1	0	1
0	1	1
1	1	0



NOTE

This parameter can be accessed only if the operating mode of the selected digital output is > 2 and <9. Example: MDO1 2<P270<9.

Function applied to the result of f(A,B) C for MDO1 P277b, (P286b, P295b, P304b)

Once the Boolean signal resulting from f(A,B) is obtained, an additional logic function can be applied to obtain the output TRUE//FALSE Boolean signal.

If parameter **P277a** is disabled, the output of f(A,B) goes directly to the corresponding digital output; if parameter P277a is enabled, the output of the output of f(A,B) becomes one of the two inputs of the second programmed block.

The user can choose one of the six Boolean tests above for the first variable - f(A,B) – and for the second variable (C). See Example 6.

MDO1 (2,3,4): Logic applied to MDO1 (2,3,4): P278, (P287, P296, P305)

The logic of the Boolean signal can be reversed at the end of the processing chain.

The user can choose whether the logic level of the digital output is POSITIVE or NEGATIVE.

(0) FALSE = a logic negation is applied (NEGATIVE logic)

(1) TRUE = no negation is applied (POSITIVE logic)



NOTE

This parameter can be accessed only if the operating mode of the selected digital output is other than zero. Example: MDO1 **P270**≠0.

26.2. Programmable Operating Modes (Diagrams)

The diagrams shown in the figures illustrate the operating structure of MDO1 digital output; the remaining digital outputs (MDO2, MDO3, and MDO4) will follow the same logics, as implemented in the relevant parameters.

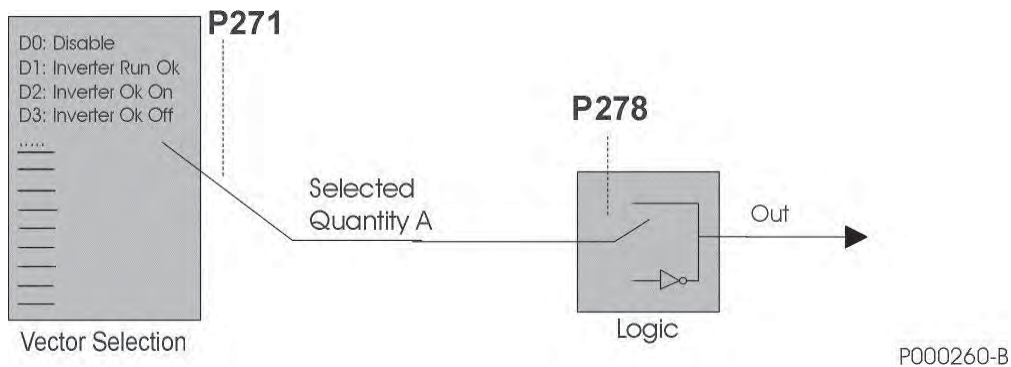
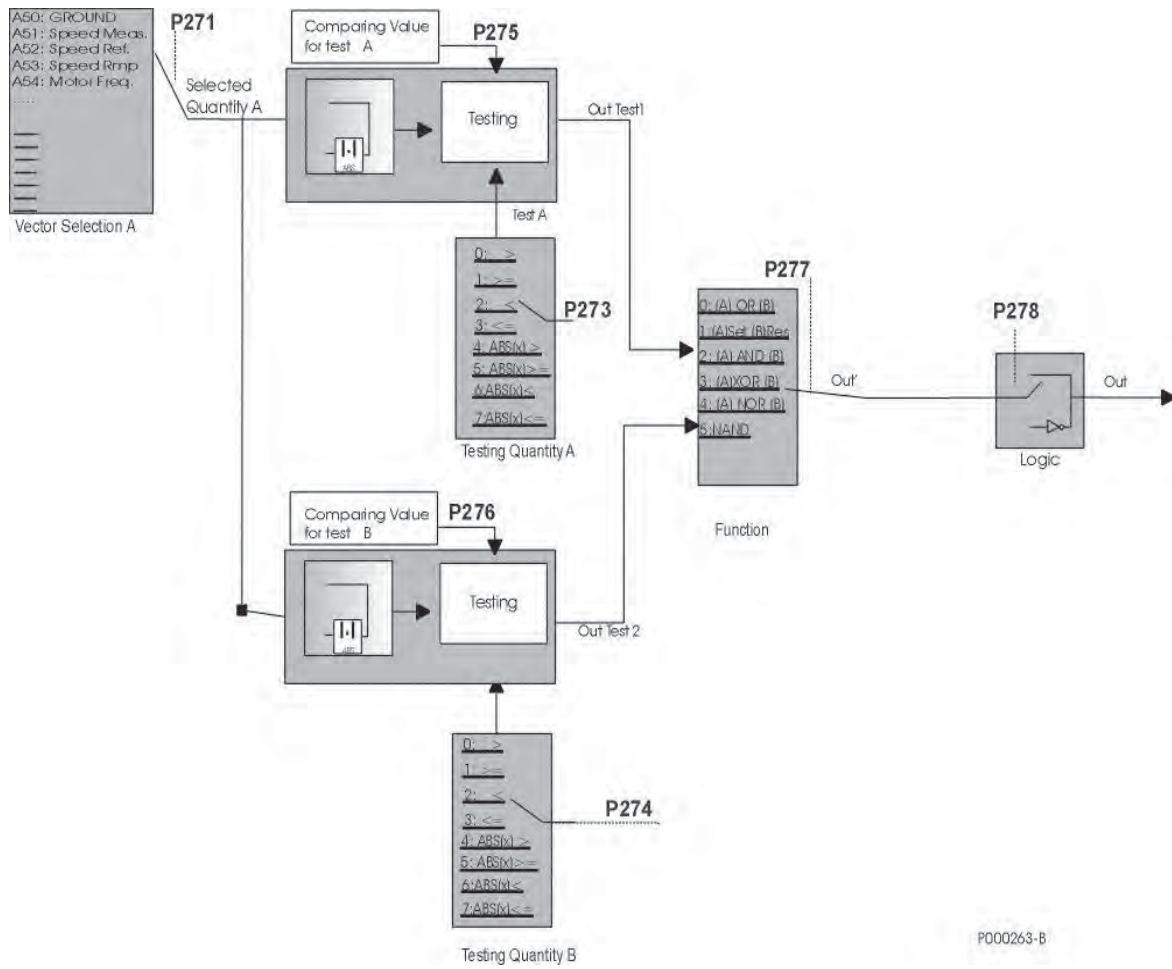
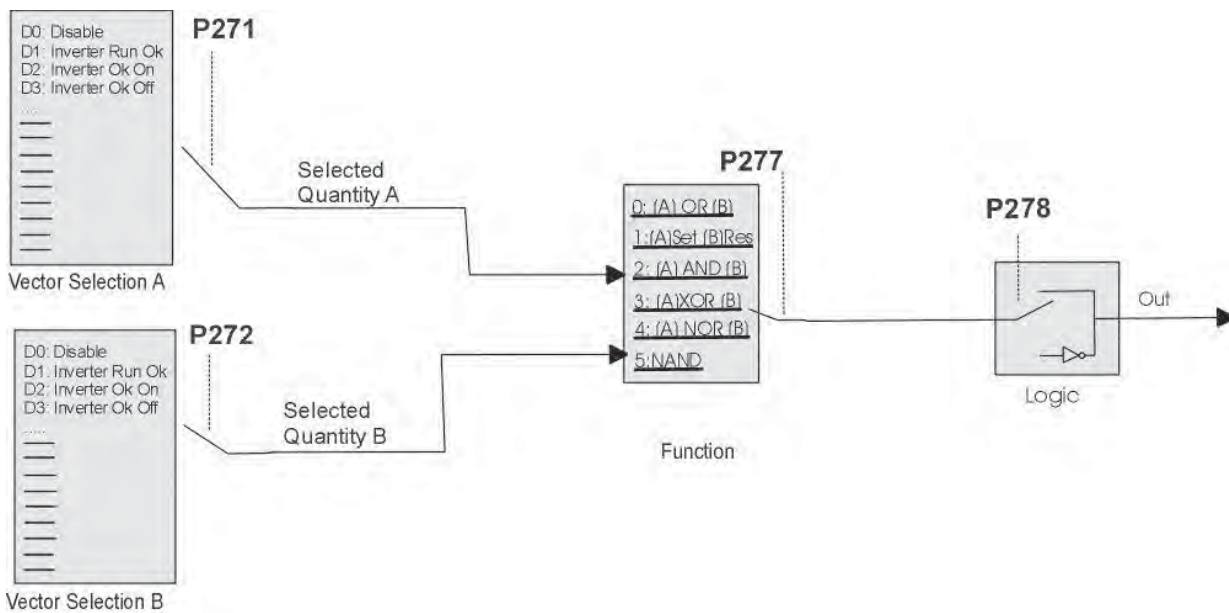

Figure 33: DIGITAL Mode



P000263-B

Figure 34: ANALOG Mode



P000261-B



Figure 35: DOUBLE DIGITAL Mode

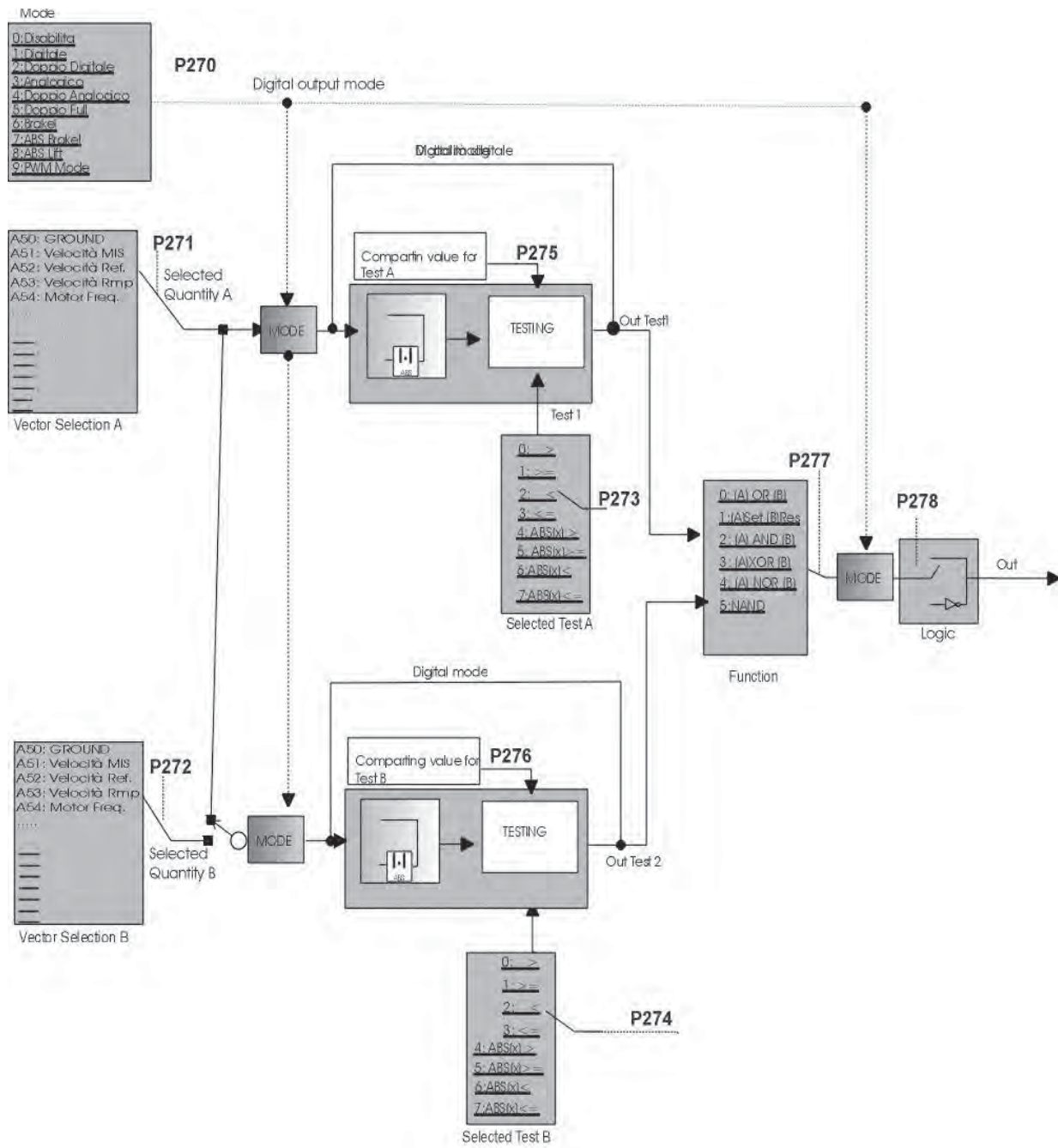

P000262-B

Figure 36: General structure of the parameterization of a digital output

26.3. Examples

This section illustrates some examples.

A table stating the setup of the parameters used is given for each example.

Parameters highlighted in grey have no effect due to their preset selection.

Example 1: Digital output for Inverter Alarm digital command (MDO3 digital output default setting).

Table 50: MDO parameterization for PD Status OK

P288	MDO3: Digital output mode	DIGITAL
P289	MDO3: Variable A selection	D3: Inverter Alarm
P290	MDO3: Variable B selection	
P291	MDO3: Testing variable A	
P292	MDO3: Testing variable B	
P293	MDO3: Comparing value for Test A	
P294	MDO3: Comparing value for Test B	
P295	MDO3: Function applied to the result of the two tests	
P295a	MDO3: Variable C selection	D0: Disabled
P295b	MDO3: Function applied to the result of f(A,B) and C test	
P296	MDO3: Output logic level	FALSE

The digital output status depends on the Boolean variable “Inverter Alarm”, which is TRUE only when an alarm trips. This output is a fail-safe contact: the relay energizes if the drive is on and no alarms tripped.

Example 2: Digital output for Drive Run OK digital command (MDO4 digital output default setting).

Table 51: MDO parameterization for drive Run OK

P297	MDO4: Digital output mode	DIGITAL
P298	MDO4: Variable A selection	D1: Drive Run Ok
P299	MDO4: Variable B selection	
P300	MDO4: Testing variable A	
P301	MDO4: Testing variable B	
P302	MDO4: Comparing value for Test A	
P303	MDO4: Comparing value for Test B	
P304	MDO4: Function applied to the result of the two tests	
P295a	MDO3: Variable C selection	D0: Disabled
P295b	MDO3: Function applied to the result of f(A,B) and C test	
P305	MDO4: Output logic level	TRUE

The digital output status depends on the Boolean variable “Drive Run Ok”, which is TRUE only when the drive is modulating (IGBTs on).

Example 3: Digital output for speed thresholds

Suppose that a digital output energizes if the motor speed exceeds 100rpm as an absolute value, and de-energizes when the motor speed is lower than or equal to 20rpm (as an absolute value). Parameter P270 sets ABS mode, so that the selected variables are considered as absolute values. The condition “greater than” is selected for test A, and “lower than/equal to” is selected for test B.

Table 52: MDO parameterization for speed thresholds

P270	MDO1: Digital output mode	DOUBLE ANALOG
P271	MDO1: Variable A selection	A71: Speed MEA
P272	MDO1: Variable B selection	A71: Speed MEA
P273	MDO1: Testing variable A	ABS(x) >
P274	MDO1: Testing variable B	ABS(x) ≤
P275	MDO1: Comparing value for Test A	100.00 rpm
P276	MDO1: Comparing value for Test B	20.00 rpm
P277	MDO1: Function applied to the result of the two tests	(A) Set (B) Reset Rising Edge
P277a	MDO1: Variable C selection	D0: Disabled
P277b	MDO1: Function applied to the result of f(A,B) and C test	
P278	MDO1: Output logic level	TRUE

Both tests are performed over the motor speed; **P271**, **P272** are set to “motor speed”. The values of reference for the two tests are 100rpm and 20rpm; the function applied is Flip Flop Set Reset and the output is considered as a true logic. Test A is the Set signal of the Flip Flop and Test B is the Reset signal.

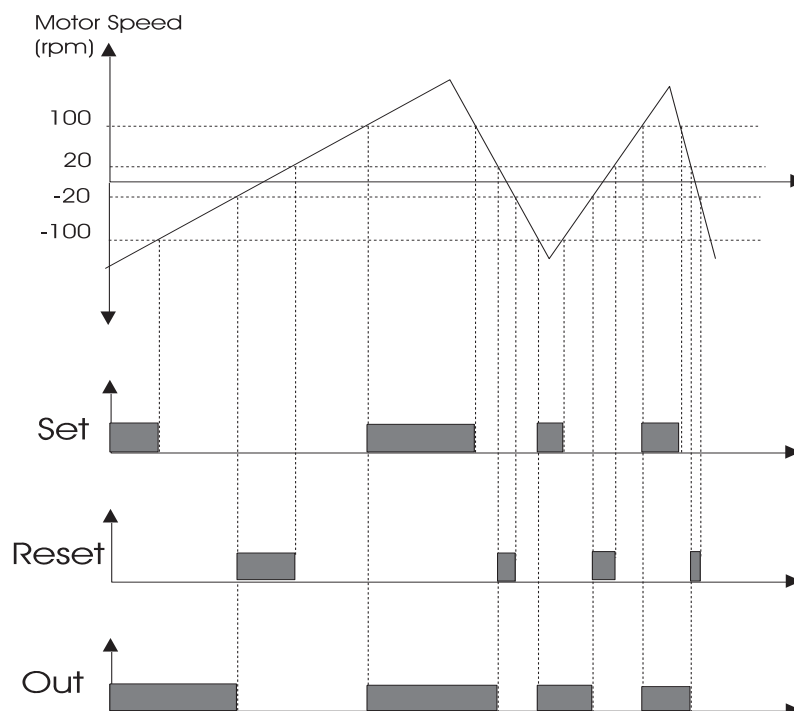

Figure 37: Digital output for speed thresholds (example)

Example 4: Digital output for electromechanical brake for hoisting applications (programming example related to MDO3 digital output).

Table 53: MDO parameterization for electromechanical brake command

P288	MDO3: Digital output mode	ABS BRAKE
P289	MDO3: Variable A selection	A81: Torque Output
P290	MDO3: Variable B selection	A71: Speed MEA
P291	MDO3: Testing variable A	>
P292	MDO3: Testing variable B	≤
P293	MDO3: Comparing value for Test A	20.00%
P294	MDO3: Comparing value for Test B	50.00 rpm
P295	MDO3: Function applied to the result of the two tests	(A) Set (B) Reset Rising Edge
P295a	MDO3: Variable C selection	D0: Disabled
P295b	MDO3: Function applied to the result of f(A,B) and C test	
P296	MDO3: Output logic level	TRUE

The digital output energizes only if no alarm trips. The torque demand is greater than **P302** = 20.00% (Set). The digital output de-energizes if an alarm trips or if the decelerating speed is lower than the speed value set in **P303** = 50rpm (Reset).

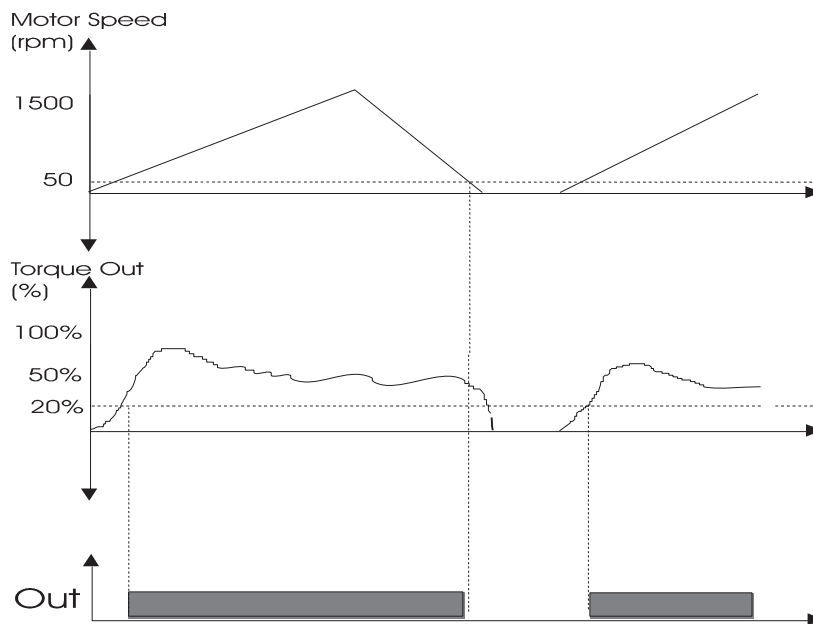

Figure 38: Electromechanical brake command (example)



CAUTION

Always use the NO contact of the digital output for the electromechanical brake command.



NOTE

For details about the electromechanical brake used for hoisting applications, see also the BRIDGE CRANE MENU.

Example 5: Using the PWM Function.

Suppose that the motor of a machine tool is controlled by a drive. The tool must be lubricated based on the cutting speed. At max. cutting speed, the electrovalve controlling lubrication must work for 0.5 sec with a frequency of 1Hz (time period of 1 sec.); at max. speed, a duty cycle of 50% (Ton/T) is required, with a time period of 1 second; the time when the electrovalve opens is directly proportional to the cutting speed.

Spd1 is the max. cutting speed and dtc1 is the duty cycle required; the saw carrier frequency required for PWM must be 1 Hz (**P213**), the min. value must be 0rpm (when speed = 0rpm, the electrovalve is disabled) and max. value = $Spd1 * 100 / dtc1 = 2 * Spd1$.

Supposing that the tool can rotate in both directions, that Spd1 = 1500rpm and that the first digital output is used, parameters are set as follows:

Table 54: MDO parameterization for the PWM function

P270	MDO1: Digital output mode	PWM MODE
P271	MDO1: Variable A selection	A72: Speed Ref.
P272	MDO1: Variable B selection	
P273	MDO1: Testing variable A	>
P274	MDO1: Testing variable B	
P275	MDO1: Comparing value for Test A	3000.00 rpm
P276	MDO1: Comparing value for Test B	0.0 rpm
P277	MDO1: Function applied to the result of the two tests	
P277a	MDO1: Variable C selection	D0: Disabled
P277b	MDO1: Function applied to the result of f(A,B) and C test	
P278	MDO1: Output logic level	TRUE
P215	Saw signal frequency	1Hz

Parameter **P215** in the ANALOG AND FREQUENCY OUTPUTS MENU sets the frequency of the saw wave, i.e. the PWM frequency of the digital output.

In PWM mode, parameter **P275** sets the max. value (peak value) of the saw wave, while parameter **P276** sets the min. value of the saw wave.

The test selected with **P273** is performed between the analog variable selected in **P271** and the saw wave.

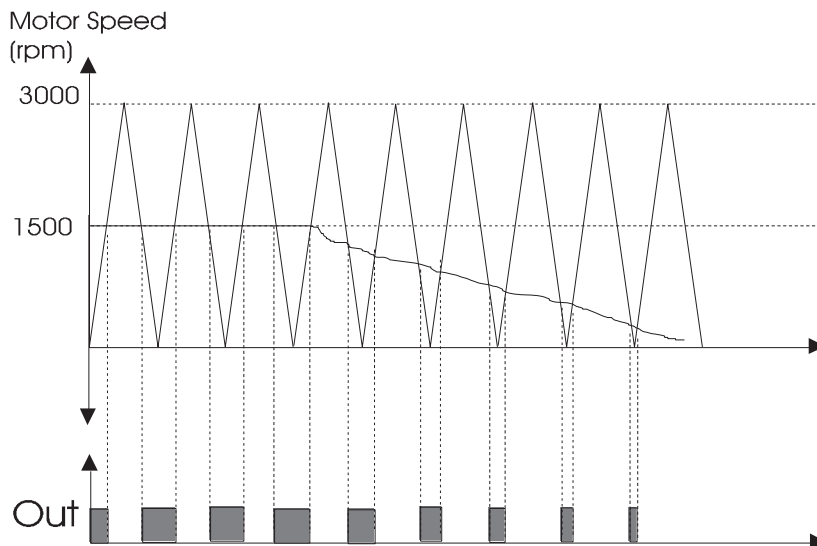



Example 6: Digital output indicating the READY state to a PLC supervisor – using Inputs A, B, C

This example shows how to activate a digital output based on the logic AND of 3 conditions A,B,C—particularly the ENABLE input, the condition of constant speed reference achieved, and the “Inverter Ok On” condition. An additional block applied to f(A,B) and C is used:

Table 55: MDO parameterization for the Ready state of a PLC supervisor

P270	MDO1: Digital output mode	DOUBLE DIGITAL
P271	MDO1: Variable A selection	D21: Enable
P272	MDO1: Variable B selection	D40: Speed OK
P273	MDO1: Testing variable A	
P274	MDO1: Testing variable B	
P275	MDO1: Comparing value for Test A	
P276	MDO1: Comparing value for Test B	
P277	MDO1: Function applied to the result of the two tests	(A) AND (B)
P277a	MDO1: Variable C selection	D2: Inverter Ok On
P277b	MDO1: Function applied to the result of f(A,B) and C test	f(A,B) AND (C)
P278	MDO1: Output logic level	TRUE

26.4. List of Parameters P270 to P305

Table 56: List of Parameters P270 to P305

Parameter	FUNCTION	User Level	DEFAULT VALUES	MODBUS Address
P270	MDO1: Digital output mode	ADVANCED	3:ANALOG	870
P271	MDO1: Selecting variable A	ADVANCED	A71: Speed	871
P272	MDO1: Selecting variable B	ADVANCED	A71: Speed	872
P273	MDO1: Testing variable A	ADVANCED	0: >	873
P274	MDO1: Testing variable B	ADVANCED	3: ≤	874
P275	MDO1: Comparing value for Test A	ADVANCED	50 rpm	875
P276	MDO1: Comparing value for Test B	ADVANCED	10 rpm	876
P277	MDO1: Function applied to the result of the 2 tests	ADVANCED	1: (A) SET (B) RESET	877
P277a	MDO1: Selecting variable C	ADVANCED	0: Disable	642
P277b	MDO1: Function applied to the result of f(A,B) C	ADVANCED	0: f(A,B) OR C	643
P278	MDO1: Output logic level	ADVANCED	1: TRUE	878
P279	MDO2: Digital output mode	ADVANCED	6: BRAKE	879
P280	MDO2: Selecting variable A	ADVANCED	A81: Trq Output	880
P281	MDO2: Selecting variable B	ADVANCED	A71: Speed	881
P282	MDO2: Testing variable A	ADVANCED	0: >	882
P283	MDO2: Testing variable B	ADVANCED	3: ≤	883
P284	MDO2: Comparing value for Test A	ADVANCED	20%	884
P285	MDO2: Comparing value for Test B	ADVANCED	50 rpm	885
P286	MDO2: Function applied to the result of the 2 tests	ADVANCED	1: (A) SET (B) RESET	886
P286a	MDO2: Selecting variable C	ADVANCED	0: Disable	644
P286b	MDO2: Function applied to the result of f(A,B) C	ADVANCED	0: f(A,B) OR C	645
P287	MDO2: Output logic level	ADVANCED	1: TRUE	887
P288	MDO3: Digital output mode	ADVANCED	1: DIGITAL	888
P289	MDO3: Selecting variable A	ADVANCED	D3: Inverter Alarm	889
P290	MDO3: Selecting variable B	ADVANCED	D3: Inverter Alarm	890
P291	MDO3: Testing variable A	ADVANCED	0: >	891
P292	MDO3: Testing variable B	ADVANCED	0: >	892
P293	MDO3: Comparing value for Test A	ADVANCED	0	893
P294	MDO3: Comparing value for Test B	ADVANCED	0	894
P295	MDO3: Function applied to the result of the 2 tests	ADVANCED	0: (A) OR (B)	895
P295a	MDO3: Selecting variable C	ADVANCED	0: Disable	646
P295b	MDO3: Function applied to the result of f(A,B) C	ADVANCED	0: f(A,B) OR C	647
P296	MDO3: Output logic level	ADVANCED	0: FALSE	896
P297	MDO4: Digital output mode	ADVANCED	1: DIGITAL	897
P298	MDO4: Selecting variable A	ADVANCED	D1: Inverter Run Ok	898
P299	MDO4: Selecting variable B	ADVANCED	D1: Inverter Run Ok	899
P300	MDO4: Testing variable A	ADVANCED	0: >	900
P301	MDO4: Testing variable B	ADVANCED	0: >	901
P302	MDO4: Comparing value for Test A	ADVANCED	0	902
P303	MDO4: Comparing value for Test B	ADVANCED	0	903
P304	MDO4: Function applied to the result of the 2 tests	ADVANCED	0: (A) OR (B)	904
P304a	MDO4: Selecting variable C	ADVANCED	0: Disable	648
P304b	MDO4: Function applied to the result of f(A,B) C	ADVANCED	0: f(A,B) OR C	649
P305	MDO4: Output logic level	ADVANCED	1: TRUE	905

P270 MDO1: Digital Output Mode

P270	Range	0 ÷ 9	0: DISABLE 1: DIGITAL 2: DOUBLE DIGITAL 3: ANALOG 4: DOUBLE ANALOG 5: DOUBLE FULL 6: BRAKE 7: ABS BRAKE 8: ABS LIFT 9: PWM MODE
	Default	3	3: ANALOG
	Level	ADVANCED	
	Address	870	
	Function	This parameter defines the operating mode of digital output 1 . The different operating modes are described at the beginning of this chapter.	



NOTE

MDO1 Digital output can be programmed only if the frequency output is not set up: **P200** = Disable (see ANALOG AND FREQUENCY OUTPUTS MENU).

P271 MDO1: Selecting Variable A

P271	Range	0 ÷ 149	See Table 48
	Default	61	A01: Speed MEA
	Level	ADVANCED	
	Address	871	
	Function	This parameter selects the digital signal used to calculate the value of MDO1 digital output. It selects an analog variable used to calculate the value of MDO1 digital output if one of the “analog” operating modes is selected. Digital signals and analog variables are detailed in See Table 48.	

P272 MDO1: Selecting Variable B

P272	Range	0 ÷ 149	See Table 48
	Default	61	A01: Speed MEA
	Level	ADVANCED	
	Address	872	
	Function	This parameter selects the second digital signal used to calculate the value of MDO1 digital output. It selects an analog variable used to calculate the value of MDO1 digital input if one of the “analog” operating modes is selected. Digital signals and analog variables are detailed in See Table 48.	

P273 MDO1: Testing Variable A

P273	Range	0 ÷ 7	0: > 1: ≥ 2: < 3: ≤ 4: ABS(x) > 5: ABS(x) ≥ 6: ABS(x) < 7: ABS(x) ≤
	Default	0	0: >
	Level	ADVANCED	
	Address	873	
	Function	This parameter defines the test to be performed for the variable detected by P271 using P275 as a comparing value.	

P274 MDO1: Testing Variable B

P274	Range	0 ÷ 7	0: > 1: ≥ 2: < 3: ≤ 4: ABS(x) > 5: ABS(x) ≥ 6: ABS(x) < 7: ABS(x) ≤
	Default	3	3: ≤
	Level	ADVANCED	
	Address	874	
	Function	This parameter defines the test to be performed for the variable detected by P272 using P276 as a comparing value.	

P275 MDO1: Comparing Value for Test A

P275	Range	-32000 ÷ 32000	-320.00 % ÷ 320.00 % <i>% of the full-scale value of selected variable A, see Table 48</i>
	Default	50	50 rpm
	Level	ADVANCED	
	Address	875	
	Function	This parameter defines the comparing value with the selected variable for test A.	

P276 MDO1: Comparing Value for Test B

P276	Range	-32000 ÷ 32000	-320.00 % ÷ 320.00 % <i>% of the full-scale value of selected variable B, see Table 48</i>
	Default	10	10 rpm
	Level	ADVANCED	
	Address	876	
	Function	This parameter defines the comparing value with the selected variable for test B.	

P277 MDO1: Function Applied to the Result of the 2 Tests

P277	Range	0 ÷ 12	0: (A) OR (B) 1: (A) SET (B) RESET 2: (A) AND (B) 3: (A) XOR (B) 4: (A) NOR (B) 5: (A) NAND (B) 6: (A\ OR (B) 7: (A) OR (B\ 8: (A\ AND (B) 9: (A) AND (B\ 10: (A) RESET (B) SET RISING EDGE 11: (A) SET (B) RESET FALLING EDGE 12: (A) RESET (B) SET FALLING EDGE
	Default	1	1: (A) SET (B) RESET
	Level	ADVANCED	
	Address	877	
	Function	This parameter determines the logic function applied to the result of the two tests allowing calculating the output value.	

P277a MDO1: Selecting Variable C

277a	Range	0 ÷ 79	See Table 48
	Default	0	D0: Disable
	Level	ADVANCED	
	Address	642	
	Function	This parameter selects the digital signal used to calculate the value of MDO1 digital output. The digital signals that can be selected are given in Table 48.	

P277b MDO1: Function Applied to the Result of f(A,B) C

P277b	Range	0 ÷ 12	0: f(A,B) OR (C) 1: f(A,B) SET (C) RESET RISING EDGE 2: f(A,B) AND (C) 3: f(A,B) XOR (C) 4: f(A,B) NOR (C) 5: f(A,B) NAND (C) 6: f(A,B)\ OR (C) 7: f(A,B) OR (C\ 8: f(A,B)\ AND (C) 9: f(A,B) AND (C\ 10: f(A,B) RESET (C) SET RISING EDGE 11: f(A,B) SET (C) RESET FALLING EDGE 12: f(A,B) RESET (C) SET FALLING EDGE
	Default	0	0: f(A,B) OR (C)
	Level	ADVANCED	
	Address	643	
	Function	This parameter determines the logic function applied to the result of the two tests allowing calculating the output value.	

P278 MDO1: Output Logic Level

P278	Range	0–1	0: FALSE 1: TRUE
	Default	1	1: TRUE
	Level	ADVANCED	
	Address	878	
	Function	MDO1 digital output logic function to apply a logic reversal (negation) to the calculated output signal: (0) FALSE = a logic negation is applied; (1) TRUE = no negation is applied.	

P279 MDO2: Digital Output Mode

P279	Range	0 ÷ 9	0: DISABLE 1: DIGITAL 2: DOUBLE DIGITAL 3: ANALOG 4: DOUBLE ANALOG 5: DOUBLE FULL 6: BRAKE 7: ABS BRAKE 8: ABS LIFT 9: PWM MODE
	Default	6	1: BRAKE
	Level	ADVANCED	
	Address	879	
	Function	This parameter defines the operating mode of digital output 2 . The different operating modes are described at the beginning of this chapter.	

P280 MDO2: Selecting Variable A

P280	Range	0 ÷ 149	See Table 48
	Default	71	A11: Torque Output
	Level	ADVANCED	
	Address	880	
	Function	This parameter selects the digital signal used to calculate the value of MDO2 digital output. It selects an analog variable used to calculate the value of MDO2 digital input if one of the “analog” operating modes is selected. Digital signals and analog variables are detailed in Table 48.	

P281 MDO2: Selecting Variable B

P281	Range	0 ÷ 149	See Table 48
	Default	61	A01: Speed MEA
	Level	ADVANCED	
	Address	881	
	Function	This parameter selects the second digital signal used to calculate the value of MDO2 digital output. It selects an analog variable used to calculate the value of MDO2 digital input if one of the “analog” operating modes is selected. Digital signals and analog variables are detailed in Table 48.	

P282 MDO2: Testing Variable A

P282	Range	0 ÷ 7	0: > 1: ≥ 2: < 3: ≤ 4: ABS(x) > 5: ABS(x) ≥ 6: ABS(x) < 7: ABS(x) ≤
	Default	0	0: >
	Level	ADVANCED	
	Address	882	
	Function	This parameter defines the test to be performed for the variable detected by P280 using P284 as a comparing value.	

P283 MDO2: Testing Variable B

P283	Range	0 ÷ 7	0: > 1: ≥ 2: < 3: ≤ 4: ABS(x) > 5: ABS(x) ≥ 6: ABS(x) < 7: ABS(x) ≤
	Default	0	3: ≤
	Level	ADVANCED	
	Address	883	
	Function	This parameter defines the test to be performed for the variable detected by P281 using P285 as a comparing value.	

P284 MDO2: Comparing Value for Test A

P284	Range	-32000 ÷ 32000	-320.00 % ÷ 320.00 % <i>% of the full-scale value of selected variable A, see Table 48</i>
	Default	2000	20%
	Level	ADVANCED	
	Address	884	
	Function	This parameter defines the comparing value with the selected variable for test A.	

P285 MDO2: Comparing Value for Test B

P285	Range	-32000 ÷ 32000	-320.00 % ÷ 320.00 % <i>% of the full-scale value of selected variable B, see Table 48</i>
	Default	50	50 rpm
	Level	ADVANCED	
	Address	885	
	Function	This parameter defines the comparing value with the selected variable for test B.	

P286 MDO2: Function Applied to the Result of the 2 Tests

P286	Range	0 ÷ 12	0: (A) OR (B) 1: (A) SET (B) RESET 2: (A) AND (B) 3: (A) XOR (B) 4: (A) NOR (B) 5: (A) NAND (B) 6: (A\ OR (B) 7: (A) OR (B\ 8: (A\ AND (B) 9: (A) AND (B\ 10: (A) RESET (B) SET RISING EDGE 11: (A) SET (B) RESET FALLING EDGE 12: (A) RESET (B) SET FALLING EDGE
	Default	1	1: (A) SET (B) RESET
	Level	ADVANCED	
	Address	886	
	Function	This parameter determines the logic function applied to the result of the two tests allowing calculating the output value.	

P286a MDO2: Selecting Variable C

P286a	Range	0 ÷ 79	See Table 48
	Default	0	D0: Disable
	Level	ADVANCED	
	Address	644	
	Function	This parameter selects the digital signal used to calculate the value of MDO2 digital output. The digital signals that can be selected are given in Table 48.	

P286b MDO2: Function Applied to the Result of f(A,B) C

P286b	Range	0 ÷ 12	0: f(A,B) OR (C) 1: f(A,B) SET (C) RESET RISING EDGE 2: f(A,B) AND (C) 3: f(A,B) XOR (C) 4: f(A,B) NOR (C) 5: f(A,B) NAND (C) 6: f(A,B)\ OR (C) 7: f(A,B) OR (C\ 8: f(A,B)\ AND (C) 9: f(A,B) AND (C\ 10: f(A,B) RESET (C) SET RISING EDGE 11: f(A,B) SET (C) RESET FALLING EDGE 12: f(A,B) RESET (C) SET FALLING EDGE
	Default	1	1: (A) SET (B) RESET
	Level	ADVANCED	
	Address	645	
	Function	This parameter determines the logic function applied to the result of the two tests allowing calculating the output value.	

P287 MDO2: Output Logic Level

P287	Range	0–1	0: FALSE 1: TRUE
	Default	1	1: TRUE
	Level	ADVANCED	
	Address	887	
	Function	MDO2 digital output logic function to apply a logic reversal (negation) to the calculated output signal: (0) FALSE = a logic negation is applied; (1) TRUE = no negation is applied.	

P288 MDO3: Digital Output Mode

P288	Range	0 ÷ 8	0: DISABLE 1: DIGITAL 2: DOUBLE DIGITAL 3: ANALOG 4: DOUBLE ANALOG 5: DOUBLE FULL 6: BRAKE 7: ABS BRAKE 8: ABS LIFT
	Default	1	1: DIGITAL
	Level	ADVANCED	
	Address	888	
	Function	This parameter defines the operating mode of digital output 3 . The different operating modes are described at the beginning of this chapter.	

P289 MDO3: Selecting Variable A

P289	Range	0 ÷ 149	See Table 48
	Default	3	D3: Inverter Alarm
	Level	ADVANCED	
	Address	889	
	Function	This parameter selects the digital signal used to calculate the value of MDO3 digital output. It selects an analog variable used to calculate the value of MDO3 digital input if one of the “analog” operating modes is selected. Digital signals and analog variables are detailed in Table 48	

P290 MDO3: Selecting Variable B

P290	Range	0 ÷ 149	See Table 48
	Default	3	D3: Inverter Alarm
	Level	ADVANCED	
	Address	890	
	Function	This parameter selects the second digital signal used to calculate the value of MDO3 digital output. It selects an analog variable used to calculate the value of digital input MDO3 if one of the “analog” operating modes is selected. Digital signals and analog variables detailed in Table 48.	

P291 MDO3: Testing Variable A

P291	Range	0 ÷ 7	0: > 1: ≥ 2: < 3: ≤ 4: ABS(x) > 5: ABS(x) ≥ 6: ABS(x) < 7: ABS(x) ≤
	Default	0	0: >
	Level	ADVANCED	
	Address	891	
	Function	This parameter defines the test to be performed for the variable detected by P289 using P293 as a comparing value.	

P292 MDO3: Testing Variable B

P292	Range	0 ÷ 7	0: > 1: ≥ 2: < 3: ≤ 4: ABS(x) > 5: ABS(x) ≥ 6: ABS(x) < 7: ABS(x) ≤
	Default	0	0: >
	Level	ADVANCED	
	Address	892	
	Function	This parameter defines the test to be performed for the variable detected by P290 using P294 as a comparing value.	

P293 MDO3: Comparing Value for Test A

P293	Range	-32000 ÷ 32000	-320.00 % ÷ 320.00 % <i>% of the full-scale value of selected variable A, see Table 48</i>
	Default	0	0
	Level	ADVANCED	
	Address	893	
	Function	This parameter defines the comparing value with the variable selected for test A.	

P294 MDO3: Comparing Value for Test B

P294	Range	-32000 ÷ 32000	-320.00 % ÷ 320.00 % <i>% of the full-scale value of selected variable B, see Table 48</i>
	Default	0	0
	Level	ADVANCED	
	Address	894	
	Function	This parameter defines the comparing value with the variable selected for test B.	

P295 MDO3: Function Applied to the Result of the 2 Tests

P295	Range	0 ÷ 12	0: (A) OR (B) 1: (A) SET (B) RESET 2: (A) AND (B) 3: (A) XOR (B) 4: (A) NOR (B) 5: (A) NAND (B) 6: (A\ OR (B) 7: (A) OR (B\ 8: (A\ AND (B) 9: (A) AND (B\ 10: (A) RESET (B) SET RISING EDGE 11: (A) SET (B) RESET FALLING EDGE 12: (A) RESET (B) SET FALLING EDGE
	Default	0	0: (A) OR (B)
	Level	ADVANCED	
	Address	895	
	Function	This parameter determines the logic function applied to the result of the two tests allowing calculating the output value.	

P295a MDO3: Selecting Variable C

P295a	Range	0 ÷ 79	See Table 48
	Default	0	D0: Disable
	Level	ADVANCED	
	Address	646	
	Function	This parameter selects the digital signal used to calculate the value of MDO3 digital output. The digital signals that can be selected are given in Table 48.	

P295b MDO3: Function Applied to the Result of f(A,B) C

P295b	Range	0 ÷ 12	0: f(A,B) OR (C) 1: f(A,B) SET (C) RESET RISING EDGE 2: f(A,B) AND (C) 3: f(A,B) XOR (C) 4: f(A,B) NOR (C) 5: f(A,B) NAND (C) 6: f(A,B)\ OR (C) 7: f(A,B) OR (C\ 8: f(A,B)\ AND (C) 9: f(A,B) AND (C\ 10: f(A,B) RESET (C) SET RISING EDGE 11: f(A,B) SET (C) RESET FALLING EDGE 12: f(A,B) RESET (C) SET FALLING EDGE
	Default	1	1: (A) SET (B) RESET
	Level	ADVANCED	
	Address	647	
	Function	This parameter determines the logic function applied to the result of the two tests allowing calculating the output value.	

P296 MDO3: Output Logic Level

P296	Range	0–1	0: FALSE 1: TRUE
	Default	0	0: FALSE
	Level	ADVANCED	
	Address	896	
	Function	MDO3 digital output logic function to apply a logic reversal (negation) to the calculated output signal: (0) FALSE = a logic negation is applied; (1) TRUE = no negation is applied.	

P297 MDO4: Digital Output Mode

P297	Range	0 ÷ 8	0: DISABLE 1: DIGITAL 2: DOUBLE DIGITAL 3: ANALOG 4: DOUBLE ANALOG 5: DOUBLE FULL 6: BRAKE 7: ABS BRAKE 8: ABS LIFT
	Default	1	1: DIGITAL
	Level	ADVANCED	
	Address	897	
	Function	This parameter defines the operating mode of digital output 4 . The different operating modes are described at the beginning of this chapter.	

P298 MDO4: Selecting Variable A

P298	Range	0 ÷ 149	See Table 48
	Default	1	D1: Inverter Run Ok
	Level	ADVANCED	
	Address	898	
	Function	This parameter selects the digital signal used to calculate the value of MDO4 digital output. It selects an analog variable used to calculate the value of MDO4 digital input if one of the “analog” operating modes is selected. Digital signals and analog variables are detailed in Table 48.	

P299 MDO4: Selecting Variable B

P299	Range	0 ÷ 149	See Table 48
	Default	1	D1: Inverter Run Ok
	Level	ADVANCED	
	Address	899	
	Function	This parameter selects the second digital signal used to calculate the value of MDO4 digital output. It selects an analog variable used to calculate the value of MDO4 digital input if one of the “analog” operating modes is selected. Digital signals and analog variables are detailed in Table 48.	

P300 MDO4: Testing Variable A

P300	Range	0 ÷ 7	0: > 1: ≥ 2: < 3: ≤ 4: ABS(x) > 5: ABS(x) ≥ 6: ABS(x) < 7: ABS(x) ≤
	Default	0	0: >
	Level	ADVANCED	
	Address	900	
	Function	This parameter defines the test to be performed for the variable detected by P298 using P302 as a comparing value.	

P301 MDO4: Testing Variable B

P301	Range	0 ÷ 7	0: > 1: ≥ 2: < 3: ≤ 4: ABS(x) > 5: ABS(x) ≥ 6: ABS(x) < 7: ABS(x) ≤
	Default	0	0: >
	Level	ADVANCED	
	Address	901	
	Function	This parameter defines the test to be performed for the variable detected by P299 using P303 as a comparing value.	

P302 MDO4: Comparing Value for Test A

P302	Range	-32000 ÷ 32000	-320.00 % ÷ 320.00 % <i>% of the full-scale value of selected variable A, see Table 48</i>
	Default	0	0
	Level	ADVANCED	
	Address	902	
	Function	This parameter defines the comparing value with the selected variable for test A.	

P303 MDO4: Comparing Value for Test B

P303	Range	-32000 ÷ 32000	-320.00 % ÷ 320.00 % <i>% of the full-scale value of selected variable B, see Table 48</i>
	Default	0	0
	Level	ADVANCED	
	Address	903	
	Function	This parameter defines the comparing value with the selected variable for test B.	

P304 MDO4: Function Applied to the Result of the 2 Tests

P304	Range	0 ÷ 12	0: (A) OR (B) 1: (A) SET (B) RESET 2: (A) AND (B) 3: (A) XOR (B) 4: (A) NOR (B) 5: (A) NAND (B) 6: (A\ OR (B) 7: (A) OR (B\ 8: (A\ AND (B) 9: (A) AND (B\ 10: (A) RESET (B) SET RISING EDGE 11: (A) SET (B) RESET FALLING EDGE 12: (A) RESET (B) SET FALLING EDGE
	Default	0	0: (A) OR (B)
	Level	ADVANCED	
	Address	904	
	Function	This parameter determines the logic function applied to the result of the two tests allowing calculating the output value.	

P304a MDO4: Selecting Variable C

P304a	Range	0 ÷ 79	See Table 48
	Default	0	D0: Disable
	Level	ADVANCED	
	Address	648	
	Function	This parameter selects the digital signal used to calculate the value of MDO4 digital output. The digital signals that can be selected are given in Table 48.	

P304b MDO4: Function Applied to the Result of f(A,B) C

P304b	Range	0 ÷ 12	0: f(A,B) OR (C) 1: f(A,B) SET (C) RESET RISING EDGE 2: f(A,B) AND (C) 3: f(A,B) XOR (C) 4: f(A,B) NOR (C) 5: f(A,B) NAND (C) 6: f(A,B)\ OR (C) 7: f(A,B) OR (C\ 8: f(A,B)\ AND (C) 9: f(A,B) AND (C\ 10: f(A,B) RESET (C) SET RISING EDGE 11: f(A,B) SET (C) RESET FALLING EDGE 12: f(A,B) RESET (C) SET FALLING EDGE
	Default	1	1: (A) SET (B) RESET
	Level	ADVANCED	
	Address	649	
	Function	This parameter determines the logic function applied to the result of the two tests allowing calculating the output value.	

P305 MDO4: Output Logic Level

P305	Range	0–1	0: FALSE 1: TRUE
	Default	1	1: TRUE
	Level	ADVANCED	
	Address	905	
	Function	MDO4 digital output logic function to apply a logic reversal (negation) to the calculated output signal: (0) FALSE = a logic negation is applied; (1) TRUE = no negation is applied.	

27. AUXILIARY DIGITAL OUTPUTS MENU

27.1. Overview

This menu includes the parameters allowing allocating the control functions implemented via the digital inputs located on I/O expansion boards. This menu can be viewed only after enabling data acquisition from the expansion boards.

27.2. List of Parameters P306 to P317

Table 57: List of Parameters P306 to P317

Parameter	FUNCTION	User Level	DEFAULT VALUES	MODBUS Address
P306	XMDO1: Signal selection	ENGINEERING	D0: Disable	906
P307	XMDO1: Output logic level	ENGINEERING	1: True	907
P308	XMDO2: Signal selection	ENGINEERING	D0: Disable	908
P309	XMDO2: Output logic level	ENGINEERING	1: True	909
P310	XMDO3: Signal selection	ENGINEERING	D0: Disable	910
P311	XMDO3: Output logic level	ENGINEERING	1: True	911
P312	XMDO4: Signal selection	ENGINEERING	D0: Disable	912
P313	XMDO4: Output logic level	ENGINEERING	1: True	913
P314	XMDO5: Signal selection	ENGINEERING	D0: Disable	914
P315	XMDO5: Output logic level	ENGINEERING	1: True	915
P316	XMDO6: Signal selection	ENGINEERING	D0: Disable	916
P317	XMDO6: Output logic level	ENGINEERING	1: True	917

P306 XMDO1: Signal Selection

P306	Range	0 ÷ 79	See Table 48
	Default	0	D0: Disable
	Level	ENGINEERING	
	Address	906	
	Function	Selects the digital signal used to calculate the value of XMDO1 digital output. It selects an analog variable used to calculate the value of XMDO1 digital input if one of the “analog” operating modes is selected. Digital signals and analog variables are detailed in Table 48.	

P307 XMDO1: Output Logic Level

P307	Range	0–1	0: FALSE 1: TRUE
	Default	1	1: TRUE
	Level	ENGINEERING	
	Address	907	
	Function	XMDO1 digital output logic function to apply a logic reversal (negation) to the calculated output signal: (0) FALSE = a logic negation is applied; (1) TRUE = no negation is applied.	

P308 XMDO2: Signal Selection

P308	Range	0 ÷ 79	See Table 48
	Default	0	D0: Disable
	Level	ENGINEERING	
	Address	908	
	Function	Selects the digital signal used to calculate the value of XMDO2 digital output. It selects an analog variable used to calculate the value of XMDO2 digital input if one of the “analog” operating modes is selected. Digital signals and analog variables are detailed in Table 48.	

P309 XMDO2: Output Logic Level

P309	Range	0–1	0: FALSE 1: TRUE
	Default	1	1: TRUE
	Level	ENGINEERING	
	Address	909	
	Function	XMDO2 digital output logic function to apply a logic reversal (negation) to the calculated output signal: (0) FALSE = a logic negation is applied; (1) TRUE = no negation is applied.	

P310 XMDO3: Signal Selection

P310	Range	0 ÷ 79	See Table 48
	Default	0	D0: Disable
	Level	ENGINEERING	
	Address	910	
	Function	Selects the digital signal used to calculate the value of XMDO3 digital output. It selects an analog variable used to calculate the value of XMDO3 digital input if one of the “analog” operating modes is selected. Digital signals and analog variables are detailed in Table 48.	

P311 XMDO3: Output Logic Level

P311	Range	0–1	0: FALSE 1: TRUE
	Default	1	1: TRUE
	Level	ENGINEERING	
	Address	911	
	Function	XMDO3 digital output logic function to apply a logic reversal (negation) to the calculated output signal: (0) FALSE = a logic negation is applied; (1) TRUE = no negation is applied.	

P312 XMDO4: Signal Selection

P312	Range	0 ÷ 79	See Table 48
	Default	0	D0: Disable
	Level	ENGINEERING	
	Address	912	
	Function	Selects the digital signal used to calculate the value of XMDO4 digital output. It selects an analog variable used to calculate the value of XMDO4 digital input if one of the “analog” operating modes is selected. Digital signals and analog variables are detailed in Table 48.	

P313 XMDO4: Output Logic Level

P313	Range	0–1	0: TRUE 1: FALSE
	Default	1	1: FALSE
	Level	ENGINEERING	
	Address	913	
	Function	XMDO4 digital output logic function to apply a logic reversal (negation) to the calculated output signal: (0) FALSE = a logic negation is applied; (1) TRUE = no negation is applied.	

P314 XMDO5: Signal Selection

P314	Range	0 ÷ 79	See Table 48
	Default	0	D0: Disable
	Level	ENGINEERING	
	Address	914	
	Function	Selects the digital signal used to calculate the value of XMDO5 digital output. It selects an analog variable used to calculate the value of XMDO5 digital input if one of the “analog” operating modes is selected. Digital signals and analog variables are detailed in Table 48.	

P315 XMDO5: Output Logic Level

P315	Range	0–1	0: FALSE 1: TRUE
	Default	1	1: TRUE
	Level	ENGINEERING	
	Address	915	
	Function	XMDO5 digital output logic function to apply a logic reversal (negation) to the calculated output signal: (0) FALSE = a logic negation is applied; (1) TRUE = no negation is applied.	



P316 XMDO6: Signal Selection

P316	Range	0 ÷ 59	See Table 48
	Default	0	D0: Disable
	Level	ENGINEERING	
	Address	916	
	Function	Selects the digital signal used to calculate the value of XMDO6 digital output. It selects an analog variable used to calculate the value of XMDO6 digital input if one of the “analog” operating modes is selected. Digital signals and analog variables are detailed in Table 48.	

P317 XMDO6: Output Logic Level

P317	Range	0–1	0: FALSE 1: TRUE
	Default	1	1: TRUE
	Level	ENGINEERING	
	Address	917	
	Function	XMDO6 digital output logic function to apply a logic reversal (negation) to the calculated output signal: (0) FALSE = a logic negation is applied; (1) TRUE = no negation is applied.	

28. MEASURE CONTROL FROM PT100

28.1. Overview

This menu relates to ES847 control board. It can be viewed only if **R023** (I/O board setting) = PT100 (see the EXPANSION BOARD CONFIGURATION MENU).

The analog inputs can be linked to measure sensors.



NOTE Set DIP-Switches 1 and 2 as follows for proper data acquisition from PT100:

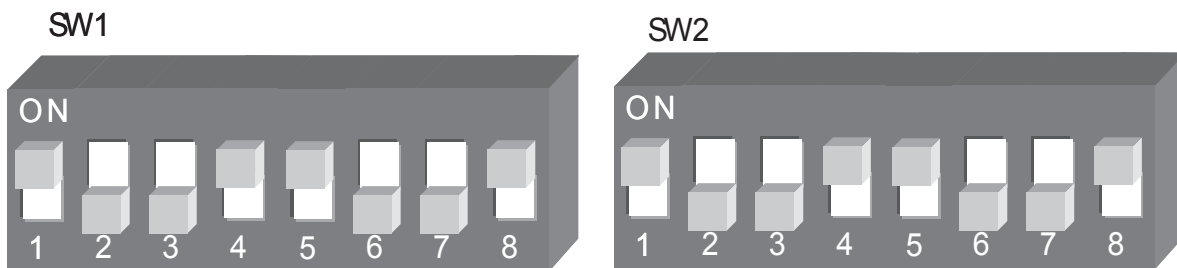

28.2. List of Parameters P318 to P325

Table 58: List of Parameters P318 to P325

Parameter	FUNCTION	User Level	DEFAULT VALUES	MODBUS Address
P320	Channel 1: measure mode	ADVANCED	0: no input	920
P321	Channel 1: measure offset	ADVANCED	0.0 °C	921
P322	Channel 2: measure mode	ADVANCED	0: no input	922
P323	Channel 2: measure offset	ADVANCED	0.0 °C	923
P324	Channel 3: measure mode	ADVANCED	0: no input	924
P325	Channel 3: measure offset	ADVANCED	0.0 °C	925
P326	Channel 4: measure mode	ADVANCED	0: no input	926
P327	Channel 4: measure offset	ADVANCED	0.0 °C	927

P320 Channel 1: Measure Mode

P320	Range	0 ÷ 1	0: no input 1: val PT100
	Default	0	0: no input
	Level	ADVANCED	
	Address	920	
	Function	This parameter selects the type of analog signal available in terminals 27–28 in ES847 expansion board. 0: no signal is used. The P parameter relating to the analog input disappears. 1: val PT100. The acquired signal is transformed into degrees centigrade. See Measure M069 .	

P321 Channel 1: Measure Offset

P321	Range	–30000 ÷ 30000	–300.00 ÷ 300.00
	Default	0	0.0 °C
	Level	ADVANCED	
	Address	921	
	Function	Value of the measure offset for channel 1: an offset can be applied to the measure to correct possible errors.	

P322 Channel 2: Measure Mode

P322	Range	0 ÷ 1	0: no input 1: val PT100
	Default	0	0: no input
	Level	ADVANCED	
	Address	922	
	Function	This parameter selects the type of analog signal available in terminals 29–30 in ES847 expansion board. 0: no signal is used. The P parameter relating to the analog input disappears. 1: val PT100. The acquired signal is transformed into degrees centigrade. See Measure M070 .	

P323 Channel 2: Measure Offset

P323	Range	–30000 ÷ 30000	–300.00 ÷ 300.00
	Default	0	0.0 °C
	Level	ADVANCED	
	Address	923	
	Function	Value of the measure offset for channel 2: an offset can be applied to the measure to correct possible errors.	

P324 Channel 3: Measure Mode

P324	Range	0 ÷ 1	0: no input 1: val PT100
	Default	0	0: no input
	Level	ADVANCED	
	Address	924	
	Function	This parameter selects the type of analog signal available in terminals 31–32 in ES847 expansion board. 0: no signal is used. The P parameter relating to the analog input disappears. 1: val PT100. The acquired signal is transformed into degrees centigrade. See Measure M071 .	

P325 Channel 3: Measure Offset

P325	Range	–30000 ÷ 30000	–300.00 ÷ 300.00
	Default	0	0.0 °C
	Level	ADVANCED	
	Address	925	
	Function	Value of the measure offset for channel 3: an offset can be applied to the measure to correct possible errors.	

P326 Channel 4: Measure Mode

P326	Range	0 ÷ 1	0: no input 1: val PT100
	Default	0	0: no input
	Level	ADVANCED	
	Address	926	
	Function	This parameter selects the type of analog signal available in terminals 33–34 in ES847 expansion board. 0: no signal is used. The P parameter relating to the analog input disappears. 1: val PT100. The acquired signal is transformed into degrees centigrade. See Measure M072 .	

P327 Channel 4: Measure Offset

P327	Range	–30000 ÷ 30000	–300.00 ÷ 300.00
	Default	0	0.0 °C
	Level	ADVANCED	
	Address	927	
	Function	Value of the measure offset for channel 4: an offset can be applied to the measure to correct possible errors.	

29. FIELDBUS PARAMETERS MENU

29.1. Overview

This menu allows selecting the Third measure and the Fourth measure from the Fieldbus.
The list of the selectable measures is the same as the list in the MEASURES MENU.
The First measure and the Second measure are fixed (Output Current and Motor Speed) (see Exchanged P).

29.2. List of Parameters P330 to P331

Table 59: List of Parameters P330 to P331

Parameter	FUNCTION	User Level	Default Values	MODBUS Address
P330	Third measure from the Fieldbus	ENGINEERING	13: Torque Out %	930
P331	Fourth measure from the Fieldbus	ENGINEERING	23: PID Out%	931

P330 Third Measure from the Fieldbus

P330	Range	0 ÷ 98	See MEASURES MENU and Table 60
	Default	13	M012 : [Torque Out %]
	Level	ENGINEERING	
	Address	930	
	Function	Third measure exchanged via Fieldbus.	

P331 Fourth Measure from the Fieldbus

P331	Range	0 ÷ 98	See MEASURES MENU and Table 60
	Default	23	M022 : [PID Out %]
	Level	ENGINEERING	
	Address	931	
	Function	Fourth measure exchanged via Fieldbus.	

Table 60: List of the programmable measures for P330 to P331

0	NONE	50	M049 FbusPID Fbk
1	M000 Speed Ref	51	M050 Encoder Ref
2	M001 dcm.Spd.Ref	52	M051 Freq.In Ref
3	M002 Ramp Out	53	M052 Op.Time (low)
4	M003 dcm.Rmp.Out	54	M052 Op.Time (high)
5	M004 Motor Speed	55	M054 Sply.Time (low)
6	M005 dcm.Mot.Spd	56	M054 Sply.Time (high)
7	M006 Mot.Freq.	57	M056 Digital Out
8	M007 Torq.Ref	58	M057 Freq.Out
9	M008 Torq.Demand	59	M058 Analog Out AO1
10	M009 Torq.Out	60	M059 Analog Out AO2
11	M010 Torq.Ref %	61	M060 Analog Out AO3
12	M011 Torq.Dem.%	62	M061 Aux. Dig.OUT
13	M012 Torq.Out %	63	M062 Amb.Temp.
14	M013 T.Lim.Ref	64	M036a Aux.Ser. Dig.IN
15	M014 T.Lim.RmpOut	65	M064 Hts.Temp.
16	M015 T.Lim.Ref %	66	M065 OT Counter
17	M016 T.Lim.RmpOut %	67	M066 ST Counter
18	M017 Flux Ref	68	M036b Aux.FBus. Dig.IN
19	M018 PID Ref %	69	M022a PID2 Out %
20	M019 PID RmpOut %	70	M069 PT100 Temp.1
21	M020 PID Fbk %	71	M070 PT100 Temp.2
22	M021 PID Err %	72	M071 PT100 Temp.3
23	M022 PID Out %	73	M072 PT100 Temp.4
24	M023 PID Ref	74	M028a Energy (low)
25	M024 PID Fbk	75	M028a Energy (high)
26	M056a Virtual Dig.Out	76	reserved
27	M026 Mot.Current	77	M013a Speed Lim Ref
28	M027 Out Volt	78	M014a Speed Lim Out
29	M028 Power Out	79	M026a I2t %
30	M029 Vbus-DC	80	M039a Analog In XAIN4
31	M030 V Mains	81	M039b Analog In XAIN5
32	M031 Delay.Dig.IN	82	M018a PID2 Ref %
33	M032 Istant.Dig.IN	83	M019a PID2 RmpOut %
34	M033 Term. Dig.IN	84	M020a PID2 Fbk %
35	M034 Ser. Dig.IN	85	reserved
36	M035 Fbus. Dig.IN	86	reserved
37	M036 Aux. Dig.IN	87	M021a PID2 Err %
38	M037 Analog In REF	88	M023a PID2 Ref
39	M038 Analog In AIN1	89	M024a PID2 Fbk
40	M039 Analog In AIN2	90	M089 Status
41	M040 Ser.SpdRef	91	M090 Alarm
42	M041 dcm.Ser.SpdRef	92	M056b Timed Flags TFL
43	M042 Fbus.SpdRef	93	M027a Power Factor
44	M043 dcm.Fbus.SpdRef	94	M004u Custom Mot. Speed
45	M044 Ser.TrqLimRef	95	M005u dcm.Cust.Mot.Spd
46	M045 Fbus.TrqLimRef	96	M009u Custom Torq.Out
47	M046 SerPID Ref	97	M120 Enc. A Pulses
48	M047 FbusPID Ref	98	M121 Enc. B Pulses
49	M048 SerPID Fbk		

30. VIRTUAL DIGITAL OUTPUTS (MPL) MENU

30.1. Overview

The Virtual Digital Outputs menu includes the parameters allowing configuring the virtual digital outputs (MPL1..4) of the Sinus Penta drive.

Virtual digital outputs are logic blocks (no hardware output is provided) allocating more complex logic functions to outputs MDO1..4: MPL virtual outputs can be feedbacked at the input of a new block (hardware or virtual block), thus allowing implementing more complex functions.



NOTE The Virtual Digital Outputs menu may be accessed only if the user level is **ADVANCED** or **ENGINEERING**.



NOTE XMDI auxiliary digital outputs (values from 13 to 20 in the parameters relating to the control functions) can be set up only after setting XMDI/O in parameter **R023**.

30.1.1. FACTORY SETTING

The four virtual digital outputs are disabled as a factory setting.

30.1.2. STRUCTURE OF THE VIRTUAL DIGITAL OUTPUTS

A virtual digital output is composed of two logic blocks allowing data processing before actuating the actual digital output. Block 2 depends on the settings in parameters **P357a** (**P366a**, **P375a**, **P384a**).

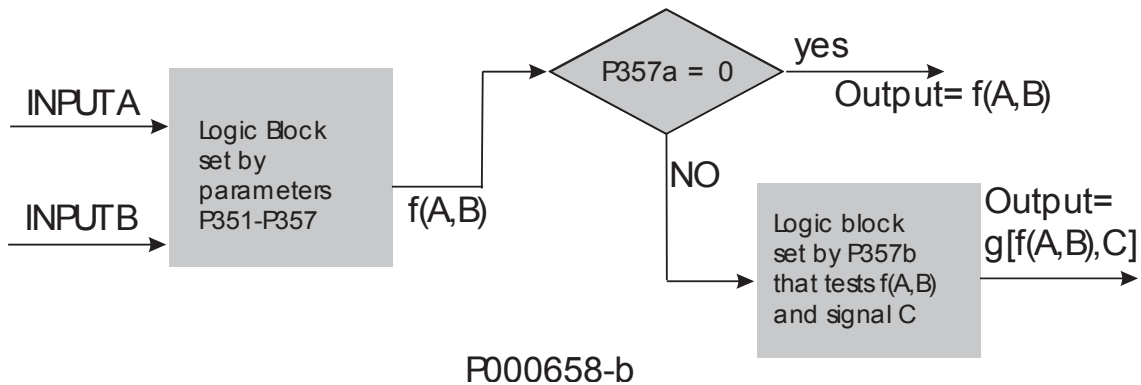

Figure 39: Block diagram of the virtual digital outputs (MPL)

Operating modes set in MPL1 (2, 3, 4): P350, (P359, P368, P377)

The user can select one of the following operating modes:

Table 61: Virtual Digital Output Modes

DISABLING	The selected digital output is disabled.
DIGITAL	The digital output depends on a selected digital signal and on the logic output function (True/False).
DOUBLE DIGITAL	The digital output depends on 2 selected digital signals, on the logic function calculating the output value and on the logic output function (True/False).
ANALOG	The digital output depends on a selected analog variable, which is tested through Test A obtaining one digital signal; starting from its value, the selected logic function calculates the True/False end value.
DOUBLE ANALOG	The digital outputs depends on 2 selected analog variables: Test A is performed for variable A, whilst Test B is performed for variable B, thus obtaining 2 digital signals; starting from their value, the selected logic function calculates the output value, whereas the logic output function True/False calculates the end value.
DOUBLE FULL	As DOUBLE ANALOG or DOUBLE DIGITAL mode, but both digital signals and analog variables can be selected. If you select a digital signal, its value (TRUE or FALSE) is used to calculate the selected logic function. If you select an analog variable, the test selected for this variable is performed, and its result (TRUE or FALSE) is used to calculate the selected logic function.
BRAKE (*)	As ABS BRAKE below, although the selected variables are not expressed as absolute values, but depend on the selected tests.
ABS BRAKE (*)	The ABS BRAKE mode allows controlling the electromechanical brake of a motor used for hoisting applications. The ABS BRAKE mode is applied by selecting the measured (or estimated) speed value [A71] as the first variable and the output torque [A80] as the second variable. Variables are considered as absolute values.
ABS LIFT (*)	As ABS BRAKE, but the brake unlocks (digital output open) when a given torque value is attained, which is automatically determined based on the last torque value required in the previous stroke.

(*) The activation and deactivation of the outputs programmed as **BRAKE**, **ABS BRAKE** and **ABS LIFT** is affected also by other conditions depending on the drive status. Namely:

Activation	Conditions to be considered in logic AND with the following programmed functions: <ul style="list-style-type: none"> • Drive accelerating or in pre-tensioning mode (see BRIDGE CRANE MENU). • Drive running, no alarm triggered
Deactivation	Conditions to be considered in logic OR with the following programmed functions: <ul style="list-style-type: none"> • Drive not running or locked due to an alarm condition • Drive in tracking error mode (see ENCODER/FREQUENCY INPUTS MENU), unless parameter C303 is set to NO (see BRIDGE CRANE MENU).



CAUTION

The digital outputs programmed as **BRAKE**, **ABS BRAKE** or **ABS LIFT** are inactive in a drive configured in **slave** mode (torque control).
In a master/slave system, both electromechanical brakes must be controlled by the master.

Variable A Selected for MPL1 (2, 3, 4): P351, (P360, P369, P378)

Selects the digital signal or the analog variable used for Test A (set with **P353 / P362 / P371 / P380**).

The whole list of the selectable items and their description are stated in Table 48.

If a digital signal is selected, Test A is not performed: therefore, the comparison value for Test A (set with **P355 / P364 / P373 / P382**) has no meaning.



NOTE

This parameter can be accessed only if the operating mode of the digital output concerned is other than zero. Example: MPL1 **P350**≠0.

Variable B selected for MPL1 (2, 3, 4): P352, (P361, P370, P379)

This selects a different digital signal or the analog variable used for Test B (set with **P354 / P363 / P372 / P381**). The whole list of the selectable items and their description are stated in Table 48.

If a digital signal is selected, Test B is not performed: therefore, the comparison value for Test B (set with **P356 / P365 / P374 / P383**) has no meaning.



NOTE

Parameter **P352** cannot be accessed when the digital output operating mode is 1: DIGITAL or 3: ANALOG.

Example: MPL1 **P350**=1 OR **P350**=3.

Testing Variable A for MPL1 (2, 3, 4): P353, (P362, P371, P380)

If an analog variable is selected, a logic TEST is performed to obtain a TRUE/FALSE Boolean signal. Eight different tests are available, that can be performed for selected variable A and its comparing value A:

Table 62: Test functions

GREATER THAN	Selected variable > comparing value
GREATER THAN/EQUAL TO	Selected variable ≥ comparing value
LOWER	Selected variable < comparing value
LOWER THAN/EQUAL TO	Selected variable ≤ comparing value
ABS, GREATER THAN	Absolute value (selected variable) > comparing value
ABS, GREATER THAN/EQUAL TO	Absolute value (selected variable) ≥ comparing value
ABS, LOWER	Absolute value (selected variable) < comparing value
ABS, LOWER THAN/EQUAL TO	Absolute value (selected variable) ≤ comparing value



NOTE

This parameter can be accessed only if the operating mode of the selected digital output is > 2. Example: MPL1 **P350**>2.

Operation on variable B, digital output MPL1 (2, 3, 4): P354, (P363, P372, P381)

If an analog variable is selected, a logic TEST is performed to obtain a TRUE/FALSE Boolean signal. Eight different tests are available, that can be performed for selected variable B and its comparing value B (see Table 62).



NOTE

This parameter can be accessed only if the operating mode of the selected digital output is > 2 and < 9. Example: MPL1 2<**P350**<9.

Reference threshold for P351 (P360, P369, P378) in MPL1 (2, 3, 4): P355, (P364, P373, P382)

Defines the comparing value of Test A with the first selected variable.



NOTE

This parameter can be accessed only if the operating mode of the selected digital output is > 2. Example: MPL1 **P350**>2.

Reference threshold for P352 (P361, P370, P379) in MPL1 (2, 3, 4): P356, (P365, P374, P383)

Defines the comparing value of Test B with the first selected variable.



NOTE

This parameter can be accessed only if the operating mode of the selected digital output is > 2. Example: MPL1 **P350**>2.

MPL1 (2, 3, 4): Function applied to the result of Tests A and B: P357, (P366, P375, P384)

A logic function is applied to the two Boolean signals obtained in order to obtain the output TRUE/FALSE Boolean signal.

(A) OR (B): The selected digital output is enabled when at least one of the two conditions below is true (this function also allows enabling the selected digital input based on one test only).

(A) OR (B)		
Test A	Test B	Output
0	0	0
1	0	1
0	1	1
1	1	1

(A) SET (B) RESET Rising Edge

(A) RESET (B) SET Rising Edge

(A) SET (B) RESET Falling Edge

(A) RESET (B) SET Falling Edge

The selected digital output is activated as the output of a Flip Flop Set Reset whose inputs are signal A and signal B. This function can be used in case of hysteresis.

The status of the input (Q_n) depends on the previous value (Q_{n-1}) and on the result of the two tests.

Signals A and B are considered only when passing from 0→1 (Rising Edge) or 1→0 (Falling Edge) and may be used both as Set and Reset command.

Example: Suppose that the output enables only when the motor speed exceeds 50rpm and disables when the motor speed drops below 5 rpm. To do so, assign the first condition to Test A, representing the Set command for Flip Flop (P351 = Motor Speed, P353 >, P355 = 50rpm), and assign the second condition to Test B, representing the Reset command (P352 = Motor Speed, P354 ≤, P356 = 5rpm). A more detailed example is given at the end of this section.

(A) SET (B) RESET Rising Edge		
Test A (Set)	Test B (Reset)	Q _n
0→1	X	1
X	0→1	0
In any other case		Q _{n-1}

(A) RESET (B) SET Rising Edge		
Test A (Reset)	Test B (Set)	Q _n
0→1	X	0
X	0→1	1
In any other case		Q _{n-1}

(A) SET (B) RESET Falling Edge		
Test A (Set)	Test B (Reset)	Q _n
1→0	X	1
X	1→0	0
In any other case		Q _{n-1}

(A) RESET (B) SET Falling Edge		
Test A (Reset)	Test B (Set)	Q _n
1→0	X	0
X	1→0	1
In any other case		Q _{n-1}

(A) AND (B): The selected digital output enables when both conditions are true.

(A) AND (B)		
Test A	Test B	Output
0	0	0
1	0	0
0	1	0
1	1	1

(A) XOR (B): The selected digital output enables when either one condition or the other is true (but not when both conditions are true at a time).

(A) XOR (B)		
Test A	Test B	Output
0	0	0
1	0	1
0	1	1
1	1	0

(A) NOR (B): The selected digital output enables when no condition is true. The NOR function between two variables corresponds to the AND of the same false variables, i.e. $(A) \text{ NOR } (B) = (\neg A) \text{ AND } (\neg B)$.

(A) NOR (B)		
Test A	Test B	Output
0	0	1
1	0	0
0	1	0
1	1	0

(A) NAND (B): The selected digital output enables when no condition is true or when only one of the two conditions is true. The NAND function between two variables corresponds to the OR of the same false variables, i.e. $(A) \text{ NAND } (B) = (\neg A) \text{ OR } (\neg B)$.

(A) NAND (B)		
Test 1	Test 2	Output
0	0	1
1	0	1
0	1	1
1	1	0



NOTE

This parameter can be accessed only if the operating mode of the selected digital output is > 2 and <9. Example: MPL1 2<P350<9.

Function applied to the result of f(A,B) C for MPL1: P357b, (P366b, P375b, P384b)

Once the Boolean signal resulting from f(A,B) is obtained, an additional logic function can be applied to obtain the output TRUE//FALSE Boolean signal.

If parameter **P357a** is disabled, the output of f(A,B) goes directly to the corresponding digital output; if parameter **P357a** is enabled, the output of the output of f(A,B) becomes one of the two inputs of the second programmed block.

The user can choose one of the six Boolean tests above for the first variable—f(A,B)—and for the second variable (C).

Logic applied to MPL1 (2, 3,4): P358, (P367, P376, P385)

The logic of the Boolean signal can be reversed at the end of the processing chain.

The user can choose whether the logic level of the digital output is POSITIVE or NEGATIVE.

(0) FALSE = a logic negation is applied (NEGATIVE logic).

(1) TRUE = no negation is applied (POSITIVE logic).



NOTE

This parameter can be accessed only if the operating mode of the selected digital output is other than zero. Example: MPL1 **P350**≠0



NOTE

Please refer to Programmable Operating Modes (Diagrams) relating to the digital outputs.

30.2. Operating Diagram of the Virtual Digital Outputs

Virtual digital outputs are software outputs that can be used as digital inputs from the following items:

- digital inputs
- digital outputs
- auxiliary digital outputs
- virtual digital outputs themselves.

They can be used for special functionality of the system, thus avoiding loop wiring on the same control board.

Example:

It can be necessary to control the status of the physical **ENABLE** contacts (**ENABLE-A** and **ENABLE-B**) of the system to cause an external alarm to trip when MPL1 is selected in parameter **C164** (DIGITAL INPUTS MENU).

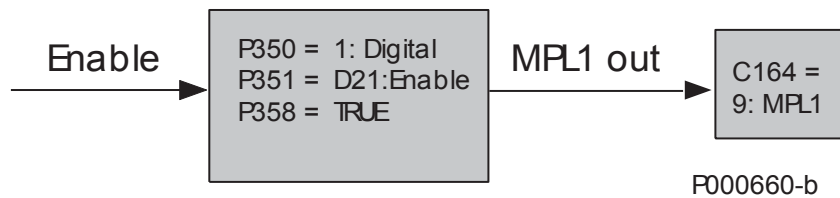

Figure 40: Example of MPL functionality

For more details about possible configurations of the virtual digital outputs, see Programmable Operating Modes (Diagrams).

Examples

This section covers some examples for the supervision of pumping systems with the PID control algorithm. The settings of the parameters being used are given in the tables below: the parameters highlighted in grey have no effect.

Example 1: Dry Run Detection

For most pumps, especially submersible bore-hole pumps, it must be assured that the pump is stopped in case of dry run. This is assured by the Dry Run Detection feature. How Does It Work?

Dry run detection is based on power/frequency monitoring. Stop (trip) due to dry run is initiated under the following conditions:

Table 63: MPL parameterization for Dry Run Detection

P359	MPL2: Digital output mode	DOUBLE ANALOG
P360	MPL2: Selecting variable A	A77: Output Power
P361	MPL2: Selecting variable B	A86: PID Feedback
P362	MPL2: Testing variable A	<
P363	MPL2: Testing variable B	<
P364	MPL2: Comparing value for Test A	Min. operating PWR [*]
P365	MPL2: Comparing value for Test B	Min. FBK value [*]
P366	MPL2: Function applied to the result of the 2 tests	(A) AND (B)
P366a	MPL2: Selecting variable C	D11: PID Out Max
P366b	MPL2: Function applied to the result of f(A,B) C	f(A,B) AND (C)
P367	MPL2: Output logic level	TRUE



NOTE It is recommended that a TIMEOUT be entered for Dry Run Detection. Enter a timeout for MPL2 output (see TIMERS MENU).

P368	MPL3: Digital output mode	DOUBLE ANALOG
P369	MPL3: Selecting variable A	A77: Output Power
P370	MPL3: Selecting variable B	A86: PID Feedback
P371	MPL3: Testing variable A	≥
P372	MPL3: Testing variable B	<
P373	MPL3: Comparing value for Test A	Min. operating PWR [*]
P374	MPL3: Comparing value for Test B	Min. FBK value [*]
P375	MPL3: Function applied to the result of the 2 tests	(A) AND (B)
P375a	MPL3: Selecting variable C	D51: MPL2
P375b	MPL3: Function applied to the result of f(A,B) C	f(A,B) OR (C)
P376	MPL3: Output logic level	TRUE



NOTE MPL3 detects when piping is clogged or faulty or when the delivery/pressure sensor is malfunctioning (e.g. the pump membrane is locked) when the sensor is located downstream of the mains.

P377	MPL4: Digital output mode	DOUBLE FULL
P378	MPL4: Selecting variable A	D51: MPL3
P379	MPL4: Selecting variable B	A86: PID Feedback
P380	MPL4: Testing variable A	
P381	MPL4: Testing variable B	≥
P382	MPL4: Comparing value for Test A	
P383	MPL4: Comparing value for Test B	Min. FBK value [*]
P384	MPL4: Function applied to the result of the 2 tests	(A) Set (B) Reset
P384a	MPL4: Selecting variable C	D0: Disabled
P384b	MPL4: Function applied to the result of f(A,B) C	
P385	MPL4: Output logic level	See steps 1. and 2. below

Virtual digital output MPL4 locks the system operation in two modes:

1. Virtually connecting the output to an external alarm input (**P385**=FALSE; **C164**=12: MPL4)
2. Disabling the PID (**P385**=TRUE; **C171**=12: MPL4)

On the other hand, when the malfunctioning signal is sent to the PLC supervisor, the same parameterization in MPL4 shall be entered in the digital output concerned.



NOTE

[*]
Min. Operating PWR = Min. power required for the pump delivery.
Min. FBK value = the min. feedback value shall be ≥ **P237** (minimum PID).



NOTE

When the Sleep Mode (see PID PARAMETERS MENU) and the Dry Run Detection mode are activated simultaneously, the delay time for the Dry Run Detection mode shall be shorter than the Sleep Mode time.

Example 2: Pipe Fill Function

The PIPE FILL function avoids water hammer in irrigation pipes. To avoid water hammer, pipes must be filled very slowly for air drainage. To do so, force a minimum rate reference, thus obtaining the minimum delivery of the pumping system. Once the min. rate is attained, the feedback starts increasing; when the filling pressure is attained, the system can start operating under normal conditions. Suppose that the feedback value of the pipe pressure is present at analog input AIN1.

Table 64: MPL parameterization for Pipe Fill function

P368	MPL3: Digital output mode	DOUBLE ANALOG
P369	MPL3: Selecting variable A	A79: AIN1
P370	MPL3: Selecting variable B	A79: AIN1
P371	MPL3: Testing variable A	<
P372	MPL3: Testing variable B	≥
P373	MPL3: Comparing value for Test A	Pressure value when the system is empty
P374	MPL3: Comparing value for Test B	Pressure value when the system is full
P375	MPL3: Function applied to the result of the 2 tests	(A) Set (B) Reset
P375a	MPL3: Selecting variable C	D0: Disabled
P375b	MPL3: Function applied to the result of f(A,B) C	
P376	MPL3: Output logic level	TRUE
P377	MPL4: Digital output mode	DIGITAL
P378	MPL4: Selecting variable A	D52: MPL3
P379	MPL4: Selecting variable B	
P380	MPL4: Testing variable A	
P381	MPL4: Testing variable B	
P382	MPL4: Comparing value for Test A	
P383	MPL4: Comparing value for Test B	
P384	MPL4: Function applied to the result of the 2 tests	
P384a	MPL4: Selecting variable C	D0: Disabled
P384b	MPL4: Function applied to the result of f(A,B) C	
P385	MPL4: Output logic level	TRUE
P009	Acceleration time 1	Ramp for normal operation [*]
P010	Deceleration time 1	Ramp for normal operation [*]
P011	Acceleration time 2	Ramp for PIPE FILL [*]
P012	Deceleration time 2	Ramp for PIPE FILL [*]
P080	Multispeed function	0: Preset Speed
P081	Output speed 1 (Mspd1)	Min. operating speed [*]
C182	MDI Multiprogramming enable	Enabled
C155	MDI for multispeed 0 selection	12: MPL4
C167	MDI for multiramp 0 selection	11: MPL3
C171	MDI for PID disable	11: MPL3

It is required to repeat MPL3 output to MPL4 output, because every MPL may be allocated to maximum 2 functions (**C182 = Enabled** – see DIGITAL INPUTS MENU). In that case, 3 functions are required, so an additional output is needed.



NOTE

[*]

Ramp for normal function = Ramp desired during normal operation.

Ramp for PIPE FILL = Ramp desired when filling the pipes.

Minimum operating speed = Min. speed required for the correct delivery of the pump.

30.3. List of Parameters P350 to P385

Table 65: List of Parameters P350 to P385

Parameter	FUNCTION	User Level	DEFAULT VALUES	MODBUS Address
P350	MPL1: Digital output mode	ADVANCED	0: DISABLE	950
P351	MPL1: Selecting variable A	ADVANCED	D0: DISABLE	951
P352	MPL1: Selecting variable B	ADVANCED	D0: DISABLE	952
P353	MPL1: Testing variable A	ADVANCED	0: >	953
P354	MPL1: Testing variable B	ADVANCED	0: >	954
P355	MPL1: Comparing value for Test A	ADVANCED	0	955
P356	MPL1: Comparing value for Test B	ADVANCED	0	956
P357	MPL1: Function applied to the result of the 2 tests	ADVANCED	0: (A) OR (B)	957
P357a	MPL1: Selecting variable C	ADVANCED	D0: DISABLE	932
P357b	MPL1: Function applied to the result of f(A,B) C	ADVANCED	0: f(A,B) OR C	933
P358	MPL1: Output logic level	ADVANCED	1: TRUE	958
P359	MPL2: Digital output mode	ADVANCED	0: DISABLE	959
P360	MPL2: Selecting variable A	ADVANCED	D0: DISABLE	960
P361	MPL2: Selecting variable B	ADVANCED	D0: DISABLE	961
P362	MPL2: Testing variable A	ADVANCED	0: >	962
P363	MPL2: Testing variable B	ADVANCED	0: >	963
P364	MPL2: Comparing value for Test A	ADVANCED	0	964
P365	MPL2: Comparing value for Test B	ADVANCED	0	965
P366	MPL2: Function applied to the result of the 2 tests	ADVANCED	0: (A) OR (B)	966
P366a	MPL2: Selecting variable C	ADVANCED	D0: DISABLE	934
P366b	MPL2: Function applied to the result of f(A,B) C	ADVANCED	0: f(A,B) OR C	935
P367	MPL2: Output logic level	ADVANCED	1: TRUE	967
P368	MPL3: Digital output mode	ADVANCED	0: DISABLE	968
P369	MPL3: Selecting variable A	ADVANCED	D0: DISABLE	969
P370	MPL3: Selecting variable B	ADVANCED	D0: DISABLE	970
P371	MPL3: Testing variable A	ADVANCED	0: >	971
P372	MPL3: Testing variable B	ADVANCED	0: >	972
P373	MPL3: Comparing value for Test A	ADVANCED	0	973
P374	MPL3: Comparing value for Test B	ADVANCED	0	974
P375	MPL3: Function applied to the result of the 2 tests	ADVANCED	0: (A) OR (B)	975
P375a	MPL3: Selecting variable C	ADVANCED	D0: DISABLE	936
P375b	MPL3: Function applied to the result of f(A,B) C	ADVANCED	0: f(A,B) OR C	937
P376	MPL3: Output logic level	ADVANCED	1: TRUE	976
P377	MPL4: Digital output mode	ADVANCED	0: DISABLE	977
P378	MPL4: Selecting variable A	ADVANCED	D0: DISABLE	978
P379	MPL4: Selecting variable B	ADVANCED	D0: DISABLE	979
P380	MPL4: Testing variable A	ADVANCED	0: >	980
P381	MPL4: Testing variable B	ADVANCED	0: >	981
P382	MPL4: Comparing value for Test A	ADVANCED	0	982
P383	MPL4: Comparing value for Test B	ADVANCED	0	983
P384	MPL4: Function applied to the result of the 2 tests	ADVANCED	0: (A) OR (B)	984
P384a	MPL4: Selecting variable C	ADVANCED	D0: DISABLE	938
P384b	MPL4: Function applied to the result of f(A,B) C	ADVANCED	0: f(A,B) OR C	939
P385	MPL4: Output logic level	ADVANCED	1: TRUE	985

P350 MPL1: Digital Output Mode

P350	Range	0 ÷ 8	0: DISABLE 1: DIGITAL 2: DOUBLE DIGITAL 3: ANALOG 4: DOUBLE ANALOG 5: DOUBLE FULL 6: BRAKE 7: ABS BRAKE 8: ABS LIFT
	Default	1	1: DIGITAL
	Level	ADVANCED	
	Address	950	
	Function	This parameter defines the operating mode of virtual digital output 1 . The different operating modes are described at the beginning of this chapter.	

P351 MPL1: Selecting Variable A

P351	Range	0 ÷ 149	See Table 48
	Default	21	D0: Enable
	Level	ADVANCED	
	Address	951	
	Function	This parameter selects the digital signal used to calculate the value of MPL1 digital output. It selects an analog variable used to calculate the value of MPL1 digital output if one of the “analog” operating modes is selected. Digital signals and analog variables are detailed in Table 48.	

P352 MPL1: Selecting Variable B

P352	Range	0 ÷ 149	See Table 48
	Default	0	D0: Disable
	Level	ADVANCED	
	Address	952	
	Function	This parameter selects the second digital signal used to calculate the value of MPL1 digital output. It selects an analog variable used to calculate the value of MPL1 digital input if one of the “analog” operating modes is selected. Digital signals and analog variables are detailed in Table 48.	

P353 MPL1: Testing Variable A

P353	Range	0 ÷ 7	0: > 1: ≥ 2: < 3: ≤ 4: ABS(x) > 5: ABS(x) ≥ 6: ABS(x) < 7: ABS(x) ≤
	Default	0	0: >
	Level	ADVANCED	
	Address	953	
	Function	This parameter defines the test to be performed for the variable detected by P351 using P355 as a comparing value.	

P354 MPL1: Testing Variable B

P354	Range	0 ÷ 7	0: > 1: ≥ 2: < 3: ≤ 4: ABS(x) > 5: ABS(x) ≥ 6: ABS(x) < 7: ABS(x) ≤
	Default	0	0: >
	Level	ADVANCED	
	Address	954	
	Function	This parameter defines the test to be performed for the variable detected by P352 using P356 as a comparing value.	

P355 MPL1: Comparing Value for Test A

P355	Range	-32000 ÷ 32000	-320.00 % ÷ 320.00 % % of the full-scale value of selected variable A, see Table 48
	Default	0	0
	Level	ADVANCED	
	Address	955	
	Function	This parameter defines the comparing value with the selected variable for test A.	

P356 MPL1: Comparing Value for Test B

P356	Range	-32000 ÷ 32000	-320.00 % ÷ 320.00 % % of the full-scale value of selected variable B, see Table 48
	Default	0	0
	Level	ADVANCED	
	Address	956	
	Function	This parameter defines the comparing value with the selected variable for test B.	

P357 MPL1: Function Applied to the Result of the 2 Tests

P357	Range	0 ÷ 12	0: (A) OR (B) 1: (A) SET (B) RESET 2: (A) AND (B) 3: (A) XOR (B) 4: (A) NOR (B) 5: (A) NAND (B) 6: (A\ OR (B) 7: (A) OR (B\ 8: (A\ AND (B) 9: (A) AND (B\ 10: (A) RESET (B) SET RISING EDGE 11: (A) SET (B) RESET FALLING EDGE 12: (A) RESET (B) SET FALLING EDGE
	Default	0	0: (A) OR (B)
	Level	ADVANCED	
	Address	957	
	Function	This parameter determines the logic function applied to the result of the tests allowing calculating the output value.	

P357a MPL1: Selecting Variable C

P357a	Range	0 ÷ 79	See Table 48
	Default	0	D0: Disable
	Level	ADVANCED	
	Address	932	
	Function	This parameter selects the digital signal used to calculate the value of MPL1 digital output. The digital signals that can be selected are given in Table 48.	

P357b MPL1: Function Applied to the Result of f(A,B) C

P357b	Range	0 ÷ 12	0: f(A,B) OR (C) 1: f(A,B) SET (C) RESET RISING EDGE 2: f(A,B) AND (C) 3: f(A,B) XOR (C) 4: f(A,B) NOR (C) 5: f(A,B) NAND (C) 6: f(A,B)\ OR (C) 7: f(A,B) OR (C\ 8: f(A,B)\ AND (C) 9: f(A,B) AND (C\ 10: f(A,B) RESET (C) SET RISING EDGE 11: f(A,B) SET (C) RESET FALLING EDGE 12: f(A,B) RESET (C) SET FALLING EDGE
	Default	0	0: f(A,B) OR (C)
	Level	ADVANCED	
	Address	933	
	Function	This parameter determines the logic function applied to the result of the two tests allowing calculating the output value.	

P358 MPL1: Output Logic Level

P358	Range	0–1	0: FALSE 1: TRUE
	Default	1	1: TRUE
	Level	ADVANCED	
	Address	958	
	Function	MPL1 digital output logic function to apply a logic reversal (negation) to the calculated output signal: (0) FALSE = a logic negation is applied; (1) TRUE = no negation is applied.	

P359 MPL2: Digital Output Mode

P359	Range	0 ÷ 8	0: DISABLE 1: DIGITAL 2: DOUBLE DIGITAL 3: ANALOG 4: DOUBLE ANALOG 5: DOUBLE FULL 6: BRAKE 7: ABS BRAKE 8: ABS LIFT
	Default	1	0: DISABLE
	Level	ADVANCED	
	Address	959	
	Function	This parameter defines the operating mode of virtual digital output 2 . The different operating modes are described at the beginning of this chapter.	

P360 MPL2: Selecting Variable A

P360	Range	0 ÷ 149	See Table 48
	Default	33	D0: Disable
	Level	ADVANCED	
	Address	960	
	Function	This parameter selects the digital signal used to calculate the value of MPL2 digital output. It selects an analog variable used to calculate the value of MPL2 digital input if one of the “analog” operating modes is selected. Digital signals and analog variables are detailed in Table 48.	

P361 MPL2: Selecting Variable B

P361	Range	0 ÷ 149	See Table 48
	Default	0	D0: Disable
	Level	ADVANCED	
	Address	961	
	Function	This parameter selects the second digital signal used to calculate the value of MPL2 digital output. It selects an analog variable used to calculate the value of MPL2 digital input if one of the “analog” operating modes is selected. Digital signals and analog variables are detailed in Table 48.	

P362 MPL2: Testing Variable A

P362	Range	0 ÷ 7	0: > 1: ≥ 2: < 3: ≤ 4: ABS(x) > 5: ABS(x) ≥ 6: ABS(x) < 7: ABS(x) ≤
	Default	0	0: >
	Level	ADVANCED	
	Address	362	
	Function	This parameter defines the test to be performed for the variable detected by P360 using P364 as a comparing value.	

P363 MPL2: Testing Variable B

P363	Range	0 ÷ 7	0: > 1: ≥ 2: < 3: ≤ 4: ABS(x) > 5: ABS(x) ≥ 6: ABS(x) < 7: ABS(x) ≤
	Default	0	0: >
	Level	ADVANCED	
	Address	963	
	Function	This parameter defines the test to be performed for the variable detected by P361 using P365 as a comparing value.	

P364 MPL2: Comparing Value for Test A

P364	Range	-32000 ÷ 32000	-320.00 % ÷ 320.00 % % of the full-scale value of selected variable A, see Table 48
	Default	0	0
	Level	ADVANCED	
	Address	964	
	Function	This parameter defines the comparing value with the selected variable for test A.	

P365 MPL2: Comparing Value for Test B

P365	Range	-32000 ÷ 32000	-320.00 % ÷ 320.00 % % of the full-scale value of selected variable B, see Table 48
	Default	0	0
	Level	ADVANCED	
	Address	965	
	Function	This parameter defines the comparing value with the selected variable for test B.	

P366 MPL2: Function Applied to the Result of the 2 Tests

P366	Range	0 ÷ 12	0: (A) OR (B) 1: (A) SET (B) RESET 2: (A) AND (B) 3: (A) XOR (B) 4: (A) NOR (B) 5: (A) NAND (B) 6: (A\ OR (B) 7: (A) OR (B\ 8: (A\ AND (B) 9: (A) AND (B\ 10: (A) RESET (B) SET RISING EDGE 11: (A) SET (B) RESET FALLING EDGE 12: (A) RESET (B) SET FALLING EDGE
	Default	1	1: (A) SET (B) RESET
	Level	ADVANCED	
	Address	966	
	Function	This parameter determines the logic function applied to the result of the two tests allowing calculating the output value.	

P366a MPL2: Selecting Variable C

P366a	Range	0 ÷ 79	See Table 48
	Default	0	D0: Disable
	Level	ADVANCED	
	Address	934	
	Function	This parameter selects the digital signal used to calculate the value of MPL2 digital output. The digital signals that can be selected are given in Table 48.	

P366b MPL2: Function Applied to the Result of f(A,B) C

P366b	Range	0 ÷ 12	0: f(A,B) OR (C) 1: f(A,B) SET (C) RESET RISING EDGE 2: f(A,B) AND (C) 3: f(A,B) XOR (C) 4: f(A,B) NOR (C) 5: f(A,B) NAND (C) 6: (A\ OR (B) 7: (A) OR (B\ 8: (A\ AND (B) 9: (A) AND (B\ 10: (A) RESET (B) SET RISING EDGE 11: (A) SET (B) RESET FALLING EDGE 12: (A) RESET (B) SET FALLING EDGE
	Default	0	0: f(A,B) OR (C)
	Level	ADVANCED	
	Address	935	
	Function	This parameter determines the logic function applied to the result of the two tests allowing calculating the output value.	

P367 MPL2: Output Logic Level

P367	Range	0–1	0: FALSE 1: TRUE
	Default	1	1: TRUE
	Level	ADVANCED	
	Address	967	
	Function	MPL2 digital output logic function to apply a logic reversal (negation) to the calculated output signal: (0) FALSE = a logic negation is applied; (1) TRUE = no negation is applied.	

P368 MPL3: Digital Output Mode

P368	Range	0 ÷ 8	0: DISABLE 1: DIGITAL 2: DOUBLE DIGITAL 3: ANALOG 4: DOUBLE ANALOG 5: DOUBLE FULL 6: BRAKE 7: ABS BRAKE 8: ABS LIFT
	Default	1	0: DISABLE
	Level	ADVANCED	
	Address	968	
	Function	This parameter defines the operating mode of virtual digital output 3 . The different operating modes are described at the beginning of this chapter.	

P369 MPL3: Selecting Variable A

P369	Range	0 ÷ 149	See Table 48
	Default	38	D0: Disable
	Level	ADVANCED	
	Address	969	
	Function	This parameter selects the digital signal used to calculate the value of MPL3 digital output. It selects an analog variable used to calculate the value of MPL3 digital input if one of the “analog” operating modes is selected. Digital signals and analog variables are detailed in Table 48.	

P370 MPL3: Selecting Variable B

P370	Range	0 ÷ 149	See Table 48
	Default	0	D0: Disable
	Level	ADVANCED	
	Address	970	
	Function	This parameter selects the second digital signal used to calculate the value of MPL3 digital output. It selects an analog variable used to calculate the value of digital input MPL3 if one of the “analog” operating modes is selected. Digital signals and analog variables are detailed in Table 48.	

P371 MPL3: Testing Variable A

P371	Range	0 ÷ 7	0: > 1: ≥ 2: < 3: ≤ 4: ABS(x) > 5: ABS(x) ≥ 6: ABS(x) < 7: ABS(x) ≤
	Default	0	0: >
	Level	ADVANCED	
	Address	971	
	Function	This parameter defines the test to be performed for the variable detected by P369 using P373 as a comparing value.	

P372 MPL3: Testing Variable B

P372	Range	0 ÷ 7	0: > 1: ≥ 2: < 3: ≤ 4: ABS(x) > 5: ABS(x) ≥ 6: ABS(x) < 7: ABS(x) ≤
	Default	0	0: >
	Level	ADVANCED	
	Address	972	
	Function	This parameter defines the test to be performed for the variable detected by P370 using P374 as a comparing value.	

P373 MPL3: Comparing Value for Test A

P293	Range	-32000 ÷ 32000	-320.00 % ÷ 320.00 % % of the full-scale value of selected variable A, see Table 48
	Default	0	0
	Level	ADVANCED	
	Address	973	
	Function	This parameter defines the comparing value with the variable selected for test A.	

P374 MPL3: Comparing Value for Test B

P374	Range	-32000 ÷ 32000	-320.00 % ÷ 320.00 % % of the full-scale value of selected variable B, see Table 48
	Default	0	0
	Level	ADVANCED	
	Address	974	
	Function	This parameter defines the comparing value with the variable selected for test B.	

P375 MPL3: Function Applied to the Result of the 2 Tests

P375	Range	0 ÷ 12	0: (A) OR (B) 1: (A) SET (B) RESET 2: (A) AND (B) 3: (A) XOR (B) 4: (A) NOR (B) 5: (A) NAND (B) 6: (A\ OR (B) 7: (A) OR (B\ 8: (A\ AND (B) 9: (A) AND (B\ 10: (A) RESET (B) SET RISING EDGE 11: (A) SET (B) RESET FALLING EDGE 12: (A) RESET (B) SET FALLING EDGE
	Default	0	0: (A) OR (B)
	Level	ADVANCED	
	Address	975	
	Function	This parameter determines the logic function applied to the result of the two tests allowing calculating the output value.	

P375a MPL3: Selecting Variable C

P375a	Range	0 ÷ 79	See Table 48
	Default	0	D0: Disable
	Level	ADVANCED	
	Address	936	
	Function	This parameter selects the digital signal used to calculate the value of MPL3 digital output. The digital signals that can be selected are given in see Table 48.	

P375b MPL3: Function Applied to the Result of f(A,B) C

P375b	Range	0 ÷ 12	0: f(A,B) OR (C) 1: f(A,B) SET (C) RESET RISING EDGE 2: f(A,B) AND (C) 3: f(A,B) XOR (C) 4: f(A,B) NOR (C) 5: f(A,B) NAND (C) 6: f(A,B)\ OR (C) 7: f(A,B) OR (C\ 8: f(A,B)\ AND (C) 9: f(A,B) AND (C\ 10: f(A,B) RESET (C) SET RISING EDGE 11: f(A,B) SET (C) RESET FALLING EDGE 12: f(A,B) RESET (C) SET FALLING EDGE
	Default	0	0: f(A,B) OR (C)
	Level	ADVANCED	
	Address	937	
	Function	This parameter determines the logic function applied to the result of the two tests allowing calculating the output value.	

P376 MPL3: Output Logic Level

P376	Range	0–1	0: TRUE 1: FALSE
	Default	1	1: TRUE
	Level	ADVANCED	
	Address	976	
	Function	MPL3 digital output logic function to apply a logic reversal (negation) to the calculated output signal: (0) FALSE = a logic negation is applied; (1) TRUE = no negation is applied.	

P377 MPL4: Digital Output Mode

P377	Range	0 ÷ 8	0: DISABLE 1: DIGITAL 2: DOUBLE DIGITAL 3: ANALOG 4: DOUBLE ANALOG 5: DOUBLE FULL 6: BRAKE 7: ABS BRAKE 8: ABS LIFT
	Default	1	0: DISABLE
	Level	ADVANCED	
	Address	977	
	Function	This parameter defines the operating mode of virtual digital output 4 . The different operating modes are described at the beginning of this chapter.	

P378 MPL4: Selecting Variable A

P378	Range	0 ÷ 149	See Table 48
	Default	0	D0: Disable
	Level	ADVANCED	
	Address	978	
	Function	This parameter selects the digital signal used to calculate the value of MPL4 digital output. It selects an analog variable used to calculate the value of MPL4 digital input if one of the “analog” operating modes is selected. Digital signals and analog variables are detailed in Table 48.	

P379 MPL4: Selecting Variable B

P379	Range	0 ÷ 149	See Table 48
	Default	0	D0: Disable
	Level	ADVANCED	
	Address	979	
	Function	This parameter selects the second digital signal used to calculate the value of MPL4 digital output. It selects an analog variable used to calculate the value of MPL4 digital input if one of the “analog” operating modes is selected. Digital signals and analog variables are detailed in Table 48.	

P380 MPL4: Testing Variable A

P380	Range	0 ÷ 7	0: > 1: ≥ 2: < 3: ≤ 4: ABS(x) > 5: ABS(x) ≥ 6: ABS(x) < 7: ABS(x) ≤
	Default	0	0: >
	Level	ADVANCED	
	Address	980	
	Function	This parameter defines the test to be performed for the variable detected by P378 using P382 as a comparing value.	

P381 MPL4: Testing Variable B

P381	Range	0 ÷ 7	0: > 1: ≥ 2: < 3: ≤ 4: ABS(x) > 5: ABS(x) ≥ 6: ABS(x) < 7: ABS(x) ≤
	Default	0	0: >
	Level	ADVANCED	
	Address	981	
	Function	This parameter defines the test to be performed for the variable detected by P379 using P383 as a comparing value.	

P382 MPL4: Comparing Value for Test A

P382	Range	-32000 ÷ 32000	-320.00 % ÷ 320.00 % % of the full-scale value of selected variable A, see Table 48
	Default	0	0
	Level	ADVANCED	
	Address	982	
	Function	This parameter defines the comparing value with the selected variable for test A.	

P383 MPL4: Comparing Value for Test B

P383	Range	-32000 ÷ 32000	-320.00 % ÷ 320.00 % % of the full-scale value of selected variable B, see Table 48
	Default	0	0
	Level	ADVANCED	
	Address	983	
	Function	This parameter defines the comparing value with the selected variable for test B.	

P384 MPL4: Function Applied to the Result of the 2 Tests

P384	Range	0 ÷ 12	0: (A) OR (B) 1: (A) SET (B) RESET 2: (A) AND (B) 3: (A) XOR (B) 4: (A) NOR (B) 5: (A) NAND (B) 6: (A\ OR (B) 7: (A) OR (B\ 8: (A\ AND (B) 9: (A) AND (B\ 10: (A) RESET (B) SET RISING EDGE 11: (A) SET (B) RESET FALLING EDGE 12: (A) RESET (B) SET FALLING EDGE
	Default	0	0: (A) OR (B)
	Level	ADVANCED	
	Address	984	
	Function	This parameter determines the logic function applied to the result of the two tests allowing calculating the output value.	

P384a MPL4: Selecting Variable C

P384a	Range	0 ÷ 79	See Table 48
	Default	0	D0: Disable
	Level	ADVANCED	
	Address	938	
	Function	This parameter selects the digital signal used to calculate the value of MPL4 digital output. The digital signals that can be selected are given in Table 48.	

P384b MPL4: Function Applied to the Result of f(A,B) C

P384b	Range	0 ÷ 12	0: f(A,B) OR (C) 1: f(A,B) SET (C) RESET RISING EDGE 2: f(A,B) AND (C) 3: f(A,B) XOR (C) 4: f(A,B) NOR (C) 5: f(A,B) NAND (C) 6: f(A,B)\ OR (C) 7: f(A,B) OR (C\ 8: f(A,B)\ AND (C) 9: f(A,B) AND (C\ 10: f(A,B) RESET (C) SET RISING EDGE 11: f(A,B) SET (C) RESET FALLING EDGE 12: f(A,B) RESET (C) SET FALLING EDGE
	Default	0	0: f(A,B) OR (C)
	Level	ADVANCED	
	Address	939	
	Function	This parameter determines the logic function applied to the result of the two tests allowing calculating the output value.	

P385 MPL4: Output Logic Level

P385	Range	0–1	0: TRUE 1: FALSE
	Default	1	1: TRUE
	Level	ADVANCED	
	Address	985	
	Function	MPL4 digital output logic function to apply a logic reversal (negation) to the calculated output signal: (0) FALSE = a logic negation is applied; (1) TRUE = no negation is applied.	



NOTE

Although it is possible to program a digital output so that it reflects the drive status, this indication is not be considered “SIL rated” as per the safety standards the STO function relates to. The STO safety function is accomplished with a dedicated and redundant hardware circuit, assessed and certified with defined SIL and PL levels, whereas the control software and the outputs implementing hardware do not meet the requirements above.

For that reason, the output signals within safety functions of the system where the drive is installed must not be used.

For details on the STO function, consult the Safe Torque Off Function - Application Manual.

31. INPUTS FOR REFERENCES FROM OPTIONAL BOARD

This menu relates to ES847 I/O expansion board. It can be viewed only if **R023** (I/O board setting) = XAIN (see the EXPANSION BOARD CONFIGURATION MENU).

In addition to the analog inputs located on the control board, a current analog input and a voltage analog input can be acquired if ES847 is fitted.

31.1. Scaling Analog Inputs XAIN4, XAIN5



NOTE

Please refer to the Sinus Penta's Motor Drives Accessories - User Manual for hardware details about analog inputs.

Two analog inputs (XAIN4, XAIN5) are located on ES847 control board.

XAIN4 is a current input and XAIN5 is a voltage input. They are both bipolar analog inputs ($-10V \div +10V$ or $-20mA \div +20mA$).

For both analog inputs, parameters **P390** to **P399** allow setting the type of signal to be acquired, offset compensation (if any), scaling to obtain a speed reference or a torque reference, the signal filtering time constant.

Parameter **P393** sets the offset of the input analog signal (if **P393**=0 offset is zero), while parameter **P394** defines the filtering time constant (factory setting: **P394** = 100ms).

The voltage signal can be bipolar ($-10V \div +10V$) or unipolar ($0V \div +10V$).

The current signal can be bipolar ($-20mA \div +20mA$), unipolar ($0mA \div +20mA$) or can have a minimum offset ($4mA \div 20mA$).

The user will set each analog input mode in parameters **P390**, **P395**.

Table 66: Analog input hardware mode

Type / Terminals	Name	Type	Parameter
Differential input / Pin 11,12	XAIN4	$\pm 10V$ Input	P390
Differential input / Pin 13,14	XAIN5	$\pm 20mA$ Input	P395



NOTE

Configurations different from the ones stated in the table above are not allowed.

Scaling is obtained by setting the parameters relating to the **linear function for the conversion** from the value read by the analog input to the corresponding speed/torque reference value.

The **conversion function** is a **straight line** passing through **2 points** in **Cartesian coordinates** having the values read by the analog input in the X-axis, and the speed/torque reference values in the Y-axis. The speed/torque reference values are multiplied by the reference percent parameters.

Each point is detected through its **two coordinates**.

The ordinates of the two points are the following:

the value of **Speed_Min** (or **Trq_Min** for the torque reference) multiplied by the percentage set with **P391a/P396a** for the **first point**; the value of **Speed_Max** (or **Trq_Max** for the torque reference) multiplied by the percentage set with **P392a/P397a** for the **second point**.

Speed_Min depends on the selected motor: see parameter **C028** (motor 1), **C071** (motor 2), or **C114** (motor 3).

Trq_Min depends on the selected motor: see parameter **C047** (motor 1), **C090** (motor 2) or **C133** (motor 3).

Speed_Max depends on the selected motor: see parameter **C029** (motor 1), **C072** (motor 2) or **C115** (motor 3).

Trq_Max depends on the selected motor: see parameter **C048** (motor 1), **C091** (motor 2), or **C134** (motor 3).

The X-axis values of the two points depend on the analog input:

XAIN4 Input:

Parameter **P391** is the X-axis of the **first point**; parameter **P392** is the X-axis of the **second point**.

XAIN5 Input:

Parameter **P396** is the X-axis of the **first point**; parameter **P397** is the X-axis of the **second point**.

(see also Scaling Analog Inputs REF, AIN1, AIN2).

31.2. List of parameters P390 to P399

Table 67: List of Parameters P390 to P399

Parameter	FUNCTION	User Level	DEFAULT VALUE	MODBUS Address
P390	Type of signal over XAIN4 input	ADVANCED	1:0÷10V	990
P391	Value of XAIN4 input producing min. reference (X-axis)	ADVANCED	0.0V	991
P391a	Percentage of Speed_Min/Trq_Min producing min. reference (Y-axis related to P391)	ADVANCED	100.0%	704
P392	Value of XAIN4 input producing max. reference (X-axis)	ADVANCED	10.0V	992
P392a	Percentage of Speed_Max/Trq_Max producing max. reference (Y-axis related to P392)	ADVANCED	100.0%	710
P393	Offset over XAIN4 input	ADVANCED	0V	993
P394	Filtering time over XAIN4 input	ADVANCED	100ms	994
P395	Type of signal over XAIN5 input	ADVANCED	3: 4÷20mA	995
P396	Value of XAIN5 input producing min. reference (X-axis)	ADVANCED	4.0mA	996
P396a	Percentage of Speed_Min/Trq_Min producing min. reference (Y-axis related to P396)	ADVANCED	100.0%	711
P397	Value of XAIN5 input producing max. reference (X-axis)	ADVANCED	20.0mA	997
P397a	Percentage of Speed_Min/Trq_Min producing min. reference (Y-axis related to P397)	ADVANCED	100.0%	712
P398	Offset over XAIN5 input	ADVANCED	0mA	998
P399	Filtering time over XAIN5 input	ADVANCED	100 ms	999

P390 Type of Signal over XAIN4 Input

P390	Range	0 ÷ 1	0: ± 10 V 1: 0 ÷ 10 V
	Default	1	1:0÷10V
	Level	ADVANCED	
	Address	990	
	Function	This parameter selects the type of single-ended, analog signal over XAIN4 terminal in the terminal board. The signal can be a voltage signal, a unipolar signal, or a bipolar signal. 0: ± 10 V Bipolar voltage input between -10V and +10V. The detected signal is saturated between these two values. 1: 0 ÷ 10 V Unipolar voltage input between 0V and +10V. The detected signal is saturated between these two values.	

P391 Value of XAIN4 Input Producing Min. Reference

P391	Range	-100 ÷ 100, if P390 = 0 0 ÷ 100, if P390 = 1	-10.0 V ÷ 10.0 V, if P390 = 0: ± 10 V 0.0 V ÷ 10.0V, if P390 = 1: 0 ÷ 10 V
	Default	0	0.0V
	Level	ADVANCED	
	Address	991	
	Function	This parameter selects the value for XAIN4 input signal for minimum reference, or better the reference set in C028 xP391a (Master mode) or in C047xP391a (Slave mode). If motor 2 is active, C071 and C090 will be used instead of C028 and C047 ; if motor 3 is active, the values set in C114 and C133 will be used.	

P391a Percentage of Speed Min/Trq Min. Producing Min. Reference (Y-axis related to P391)

P391a	Range	0 ÷ 1000	100.0%
	Default	1000	100.0%
	Level	ADVANCED	
	Address	704	
	Function	This parameter represents the min. speed percentage (or the min. torque percentage for a torque reference) to be used for the minimum reference set with P391 .	

P392 Value of XAIN4 Input Producing Max. Reference (X-axis)

P392	Range	-100 ÷ 100, if P390 = 0 0 ÷ 100, if P390 = 3	-10.0 V ÷ 10.0 V, if P390 = 0: ± 10 V 0.0 V ÷ 10.0V, if P390 = 1: 0 ÷ 10 V
	Default	100	+10.0V
	Level	ADVANCED	
	Address	992	
	Function	This parameter selects the value for XAIN4 input signal for maximum reference, or better the reference set in C029xP392a (Master mode) or in C048xP392a (Slave mode). If motor 2 is active, C072 and C091 will be used instead of C029 and C048 ; if motor 3 is active, the values set in C115 and C134 will be used.	

P392a Percentage of Speed Max/Trq Max Producing Max. Reference (Y-axis related to P392)

P392a	Range	0 ÷ 1000	100.0%
	Default	1000	100.0%
	Level	ADVANCED	
	Address	710	
	Function	This parameter represents the max. speed percentage (or the max. torque percentage for a torque reference) to be used for the maximum reference set with P392 .	

P393 Offset over XAIN4 Input

P393	Range	-1000 ÷ 1000	-10.00 V ÷ +10.00 V
	Default	0	0.00 V
	Level	ADVANCED	
	Address	993	
	Function	This parameter selects the offset correction value of the XAIN4 analog signal that has been measured. The value set is added to the signal measured before saturation or conversion; its unit of measure is the same as the one of the signal selected for XAIN4 analog input.	

**SINUS PENTA
PENTA MARINE**



PROGRAMMING GUIDE

P394 Filtering Time over XAIN4 Input

P394	Range	0 ÷ +65000	0 ÷ +65000ms
	Default	100	100 ms
	Level	ADVANCED	
	Address	994	
	Function	This parameter selects the value of the filter time constant of the first command applied to the XAIN4 input signal when the signal saturation and conversion is over.	

P395 Type of Signal over XAIN5 Input

P395	Range	2 ÷ 4	2: ± 20 mA 3: 4 ÷ 20 mA 4: 0 ÷ 20 mA
	Default	3	3: 4 ÷ 20 mA
	Level	ADVANCED	
	Address	995	
	Function	This parameter selects the type of differential analog signal over terminals XAIN5+ and XAIN5- in the terminal board. The signal can be a current signal, a unipolar signal, or a bipolar signal. 2: ±20 mA Bipolar current input between -20mA and +20mA. The detected signal is saturated between these two values. 3: 4 ÷ 20 mA Unipolar current input with min. threshold, between +4 mA and +20mA. The detected signal is saturated between these two values. Before being saturated, if the detected signal is lower than 4 mA or greater than 20 mA, alarms A069 or A086 trip. 4: 0 ÷ 20 mA Unipolar current input between +0 mA and +20mA. The detected signal is saturated between these two values.	

P396 Value of XAIN5 Producing Min. Reference (X-axis)

P396	Range	-200 ÷ 200, if P395 = 2 +40 ÷ 200, if P395 = 3 0 ÷ 200, if P395 = 4	-20.0 mA ÷ 20.0 mA, if P395 = 2: ± 20 mA +4.0mA ÷ 20.0 mA, if P395 = 3: 4 ÷ 20 mA 0.0 mA ÷ 20.0 mA, if P395 = 4: 0 ÷ 20 mA
	Default	40	+4.0mA
	Level	ADVANCED	
	Address	996	
	Function	This parameter selects the value for XAIN5 input signal for minimum reference, or better the reference set in C028xP396a (Master mode) or in C047xP396a (Slave mode). If motor 2 is active, C071 and C090 will be used instead of C028 and C047 ; if motor 3 is active, the values set in C114 and C133 will be used.	

P396a Percentage of Speed Min/Trq Min Producing Min. Reference (Y-axis related to P396)

P396a	Range	0 ÷ 1000	100.0%
	Default	1000	100.0%
	Level	ADVANCED	
	Address	711	
	Function	This parameter represents the min. speed percentage (or the min. torque percentage for a torque reference) to be used for the minimum reference set with P396 .	

P397 Value of XAIN5 Input Producing Max. Reference (X-axis)

P397	Range	-200 ÷ 200, if P395 = 2 +40 ÷ 200, if P395 = 3 0 ÷ 200, if P395 = 4	-20.0 mA ÷ 20.0 mA, if P395 = 2: ± 20 mA +4.0mA ÷ 20.0 mA, if P395 = 3: 4 ÷ 20 mA 0.0 mA ÷ 20.0 mA, if P395 = 4: 0 ÷ 20 mA
	Default	200	+20.0mA
	Level	ADVANCED	
	Address	997	
	Function	This parameter selects the value for XAIN5 input signal for maximum reference, or better the reference set in C029xP397a (Master mode) or in C048xP397a (Slave mode). If motor 2 is active, C072 and C091 will be used instead of C029 and C048 ; if motor 3 is active, the values set in C115 and C134 will be used.	

P397a Percentage of Speed Max/Trq Max Producing Max. Reference (Y-axis related to P397)

P397a	Range	0 ÷ 1000	100.0%
	Default	1000	100.0%
	Level	ADVANCED	
	Address	712	
	Function	This parameter represents the max. speed percentage (or the max. torque percentage for a torque reference) to be used for the maximum reference set with P397 .	

P398 Offset over XAIN5 Input

P398	Range	-2000 ÷ 2000	- 20.00 mA ÷ +20.00 mA
	Default	0	0 mA
	Level	ADVANCED	
	Address	998	
	Function	This parameter selects the offset correction value of XAIN5 analog signal that has been measured. The value set is added to the signal measured before saturation or conversion; its unit of measure is the same as the one of the signal selected for XAIN5 analog input.	

P399 Filtering Time over XAIN5 Input

P399	Range	0 ÷ +65000	0 ÷ +65000ms
	Default	100	100 ms
	Level	ADVANCED	
	Address	999	
	Function	This parameter selects the value of the filter time constant of the first command applied to XAIN5 input signal when the signal saturation and conversion is over.	

32. AUTOTUNE MENU

32.1. Overview



NOTE See the FIRST STARTUP section for tuning based on the control algorithm to be used.



NOTE At the end of the Autotune procedure, the system automatically saves the whole parameter set of the drive.



NOTE Autotune must be performed only after entering the motor ratings or the ratings of the encoder used as a speed feedback. Please refer to the MOTOR CONFIGURATION MENU and the ENCODER/FREQUENCY INPUTS MENU.

The selected motor may be tuned in order to obtain the machine ratings or the parameterization required for the correct functioning of the control algorithms. The user can also check the proper operation/wiring of the encoder used as a speed feedback.

The Autotune menu includes two programming inputs, **I073** and **I074**. Input **I073** allows enabling and selecting the type of autotune. Input **I074**—which can be programmed only if **I073** = Motor Tune— describes the type of autotune which is performed. Because the values set in **I073** or **I074** cannot be changed once for all and are automatically reset after autotune, the **ENABLE-A** **ENABLE-B** signals must be disabled and the **ESC** key must be used to accept the new value.

32.1.1. MOTOR AUTOTUNE AND ADJUSTING LOOPS

Set **I073** as Motor Tune to enable autotune functions that can be selected with **I074**.

For the correct operation of the tuning algorithms, enter the motor ratings and the ratings of the encoder used as a speed feedback.

If the carrier frequency is changed via parameters **C001** or **C002**, the current control loop and the flux control loop of the VTC or FOC regulator are to be adjusted again (see “VTC” Control Algorithm and “FOC” Control).



NOTE The autotune procedure computes the motor parameters and the regulators parameters regardless of the control algorithm selected via **C010/C053/C096**. Therefore, it is possible to perform the autotune procedure before selecting the type of motor control to be applied.

Please refer to the MOTOR CONFIGURATION MENU and the ENCODER/FREQUENCY INPUTS MENU.

Table 68: Programmable “Motor Tune” functions

Value of I074	Motor rotation	Tuning
[0: Motor Params]	no	<p>Motor parameter tuning through automatic estimation based on motor measurements or ratings. Tuning required for the correct operation of VTC, FOC and IFD control with slip compensation.</p> <p>The following parameters are computed (parameter names are given for motor M1 only):</p> <ul style="list-style-type: none"> - Stator resistance C022, through automatic estimation - Leakage inductance C023, through automatic estimation - If C021=0, a first trial value for no-load current C021 is computed based on the motor ratings (rated power in particular), otherwise, the value in C021 is not changed. An accurate value for C021 is required when using VTC and FOC control algorithms, so it is recommended that it is measured by means of a special test as detailed in the FIRST STARTUP section - Mutual inductance C024, based on motor ratings and no-load current - If C025=0, a first trial value for rotor time constant C025, otherwise the value in C025 is not changed. Although a first trial value for the rotor time constant is computed, the correct operation of the VTC and FOC control algorithms requires that the rotor time constant is computed via the procedure I074 = [2: Control YES rot] or is manually and properly entered.
[1: Control NO rot]	no	<p>Autotune of the current loop for VTC and FOC algorithms. For the correct operation of the VTC and FOC algorithms, it is possible to perform this type of tuning if the motor shaft cannot rotate.</p> <p>During that procedure, current pulses are applied to the motor. The current amplitude of the current pulses is up to the rated current.</p> <p>Before performing this procedure, tune motor parameters through I074 = [0: Motor Params].</p> <p>The following parameters are computed:</p> <ul style="list-style-type: none"> - VTC control: P175t1 (proportional gain of the current control) and P175u1 (integral time of the current control) through motor measurements. - FOC control: current regulator and flux control parameters P155, P156, P158, P159.
[2: Control YES rot]	yes	<p>Autotune of the rotor time constant (through motor measurements) and the VTC or FOC control. For the correct operation of the VTC and FOC algorithms, it is possible to perform this type of tuning if the motor shaft can rotate with no connected load. If the motor cannot rotate, perform procedure I074 = [1: Control NO rot], that does not automatically estimate the rotor time constant.</p> <p>During this procedure, current pulses are first applied to the motor when the rotor is standstill (current pulse amplitude is up to the rated current). Consequently, the motor is started with no connected load up 70% of the rated speed.</p> <p>The following parameters are computed:</p> <ul style="list-style-type: none"> - for the VTC control, P175t1 (proportional gain of the current control) and P175u1 (integral time of the current control) are computed through motor measurements. - for the FOC control, P155, P156 for the current regulator are computed. <p>This procedure computes and saves the rotor time constant C025 through motor measurements.</p>



NOTE

When the rotor time constant tuning is completed and whenever the value of the time constant is manually changed, parameters **P158** and **P159** are changed as well based on the time constant value that has been set up.



32.1.2. CHECKING THE ENCODER OPERATION

Set **I073** as Encoder Tune to check the correct operation of the incremental encoder selected as a speed feedback (see the ENCODER/FREQUENCY INPUTS MENU) and to automatically set the correct direction of rotation.



NOTE

Before checking the correct operation of the encoder used as a speed feedback, **enter the motor ratings and the encoder ratings.**

Please refer to the MOTOR CONFIGURATION MENU and the ENCODER/FREQUENCY INPUTS MENU.

Once **I073** is set as Encoder Tune and the **ENABLE-A** and **ENABLE-B** terminals have been closed, the connected motor attains a speed of rotation of approx. 150 rpm; its speed of rotation is detected by the encoder, then the drive is disabled. The following messages can be displayed on the display/keypad:

A059 Encoder Fault

W31 Encoder OK

Then the following message is always displayed:

W32 OPEN ENABLE

If alarm **A059 Encoder Fault** trips: in the encoder input, the value measured by the drive does not match with the actual speed of rotation of the motor. Check that the encoder is properly set up (see the ENCODER/FREQUENCY INPUTS MENU) and wired; if the Encoder B input is used, check the Configuration of the dip-switches located on **ES836** or **ES913** optional board (see the Sinus Penta's Motor Drives Accessories - User Manual).

If **W31 Encoder OK** appears: the speed feedback from encoder is correct.

In addition, the autotune sets the encoder signal as feedback with parameter **C199**.

32.2. List of Inputs I073 - I074

Table 69: List of Inputs I073 - I074

Input	FUNCTION	User Level	MODBUS Address
I073	Type of autotune	BASIC	1460
I074	Type of motor tune	BASIC	1461

I073 Type of Autotune

I073	Range	0 ÷ 2	0: Disable 1: Motor Tune 2: Encoder Tune
	Default	This is not a programming parameter: the input is set to zero whenever the drive is powered on and whenever the command is executed.	
	Level	BASIC	
	Address	1460	
	Function	<p>I073 selects the type of tune to perform.</p> <p>If you select [1: Motor Tune]: I074 sets different types of tune for current loops, flux loops and speed loops and for the estimation of the motor ratings (see Motor Autotune and Adjusting Loops).</p> <p>If you select [2: Encoder Tune]: you can check the correct operation of the encoder used as a speed feedback (see Checking the Encoder Operation).</p>	

I074 Type of Motor Tune

I074	Range	0 ÷ 2	0: Motor Params 1: Control NO rot 2: Control YES rot
	Default	This is not a programming parameter: the input is set to zero whenever the drive is powered on and whenever the command is executed.	
	Level	BASIC	
	Address	1461	
	Function	I074 selects the type of autotune to perform if I073 = [1: Motor Tune] (see section Motor Autotune and Adjusting Loops).	



NOTE

No changes can be made to I073 and I074 when the **ENABLE-A** and **ENABLE-B** signals are present. If you attempt to change these values when the **ENABLE-A** and **ENABLE-B** signals are present, “**W34 ILLEGAL DATA**” warning appears. Remove the **ENABLE-A** and **ENABLE-B** signals to change these values and activate them again to begin the selected autotune process.



NOTE

If **SAVE/ENTER** is pressed to store the changes made to I073 and I074, “**W17 SAVE IMPOSSIBLE**” warning appears. Use the **ESC** key instead.

33. CARRIER FREQUENCY MENU

33.1. Overview

The Carrier Frequency Menu makes it possible to set some of the PWM modulation characteristics based on the preset type of control.

33.1.1. CARRIER FREQUENCY SETTING

It is possible to gain access to all the parameters included in the Carrier Frequency menu. The user can set the minimum value and the maximum value of the switching carrier frequency and the number of pulses per period used to produce the output frequency when switching from min. carrier frequency to max. carrier frequency (synchronous modulation).

The silent modulation function can also be enabled (**C004**).

33.1.2. EXAMPLE

Setting two levels of carrier frequency and the number of pulses used for synchronous modulation. A lower value for carrier frequency ensures a better performance of the motor in terms of output torque but implies higher noise levels. Suppose that the connected motor has a rated speed equal to 1500rpm at 50Hz and that you need the best performance up to 200rpm and a “noiseless” carrier frequency at max. speed (3000rpm). In this case, the max. speed of the drive will produce an output voltage with a frequency value equal to 100Hz; in proximity to this speed the carrier frequency should be at its maximum level. Suppose that a model implementing max. 16kHz carrier frequency is used.

Assign the following:

C001 = 1600Hz

C002 = 16000Hz

C003 ≥ (C002/100Hz) = (160 pulses per period)

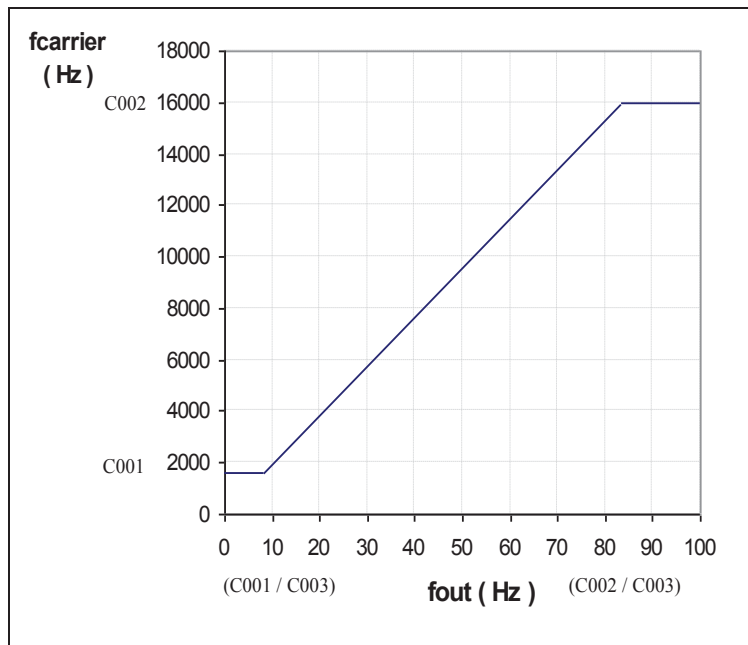

Figure 41: Carrier frequency (example)

Suppose that **C003** = 192np, so that **C002/C003** = 16000/192 = 83.33Hz. The max. carrier frequency is obtained with this output frequency. The min. frequency is kept constant until frequency **C001/C003** = 8.33 Hz is attained,



corresponding to 250 rpm of the motor speed. In the output frequency range, ranging from 8.33 to 83.33Hz, synchronous modulation is obtained and the carrier frequency applied results from: $f_{\text{carrier}} = f_{\text{out}} * \mathbf{C003}$ [Hz].

33.1.3. MAXIMUM PROGRAMMABLE SPEED VALUE

The maximum preset carrier frequency value also limits the maximum speed value to be programmed:

Max. programmable speed → **rated speed * (maximum output frequency/rated frequency)**
where the maximum output frequency results from the following:

$C002 \leq 5000\text{Hz}$	$f_{out_max} = C002 / 10$
$5000\text{Hz} < C002 \leq 8000\text{Hz}$	$f_{out_max} = 500$
$8000\text{Hz} < C002$	$f_{out_max} = C002 / 16$

C002 is the maximum carrier frequency and the divisor is the min. allowable number of pulses per period.

Table 70: Maximum value of the output frequency depending on the Penta model

Model	Max. output frequency (Hz) (*)
	2T/4T
0005 to 0014	599 (**)
0015 to 0129	599 (***)
0150 to 0402	500
0457 to 2076	400 (****)

(**) 1000Hz on demand, except for models 0008, 0010 and 0013 (625Hz on demand)

(***) 625Hz on demand, except for models 0040 (1000Hz on demand) and 0049 (800Hz on demand)

(****) 500Hz for models 0523, 0599, 0749, 0832, 0850, 0965 and 1129

Model	Max. Output Frequency (Hz) (*)
	5T/6T
0003 to 0069	500
0076 to 0600	400
0748 to 2076	200 (*****)

(*****) 400Hz for models 0750, 0828, 0960 and 1128



(*) **NOTE** The maximum output frequency is limited to the speed level programmed in parameters **C028**, **C029** [-32000 ÷ 32000]rpm. This results in $F_{out_max} = (RPM_{max} * NPole) / 120$.

EXAMPLE:

When using a 4-pole motor and 30,000rpm are required, F_{out} will be 1000Hz, so the performance requirements are fulfilled.

On the other hand, if the same performance requirements are needed with an 8-pole system, 30,000rpm cannot be obtained, as F_{out} is 2000Hz. As a result, when using an 8-pole motor, the maximum allowable programmable speed is 15,000rpm [$RPM_{outmax} = (F_{outmax} * 120) / (\text{number of motor poles})$].

33.2. List of Parameters C001 to C004

Table 71: List of Parameters C001 to C004

Parameter	FUNCTION	User Level	MODBUS Address	Default Values
C001	Minimum carrier frequency	ENGINEERING	1001	See Table 81 and Table 85
C002	Maximum carrier frequency	ENGINEERING	1002	See Table 81 and Table 85
C003	Number of pulses	ENGINEERING	1003	1:[24]
C004	Silent modulation	ENGINEERING	1004	See Table 81 and Table 85

The default value and the max. value of carrier frequency (**C001** and **C002**) depend on the drive model. To check those values, see Table 81 and Table 85.



CAUTION

If the carrier frequency is changed via parameters **C001** or **C002**, it is advisable to adjust the current control loop and the flux control loop of the VTC or FOC regulator again (see “VTC” Control Algorithm and “FOC” Control Algorithm).

C001 Minimum Carrier Frequency

C001	Range	1600 ÷ 16000 <i>Depending on the drive model</i>	1600 ÷ 16000 Hz <i>Depending on the drive model – See Table 81 and Table 85</i>
	Default	See Table 81 and Table 85	
	Level	ENGINEERING	
	Address	1001	
	Function	This parameter represents the min. value of the modulation frequency being used.	



NOTE

The minimum value in **C001** cannot exceed the maximum value in **C002**. If you want to increase the minimum value and **C001** and **C002** are set the same value, it is necessary to increase the maximum value in **C002** before proceeding.

C002 Maximum Carrier Frequency

C002	Range	1600 ÷ 16000 <i>Depending on the drive model</i>	1600 ÷ 16000 Hz <i>Depending on the drive model – See Table 81 and Table 85.</i>
	Default	See Table 81 and Table 85.	
	Level	ENGINEERING	
	Address	1002	
	Function	This parameter represents the max. value of the modulation frequency being used.	



NOTE

The max. value set in **C002** cannot be lower than the min. value set in **C001**. Decrease the min. value in **C001** if you need to decrease the max. value and if **C001** equals **C002**.



NOTE

The max. value in **C002** also determines the max. allowable speed value for the selected motor, in order to ensure a minimum number of pulses per period of frequency produced. This value is 16 for maximum carrier frequency (max. **C002** value) greater than 5kHz and 10 for lower maximum carrier frequency (see Table 81 and Table 85). See also Maximum Programmable Speed Value.

C003 Pulse Number

C003	Range	0-5	0: [12] 1: [24] 2: [48] 3: [96] 4: [192] 5: [384]
	Default	1	1: [24]
	Level	ENGINEERING	
	Address	1003	
	Function	This parameter has effect only if C001 ≠ C002 . It represents the min. value of pulses per period obtained when modulation frequency changes (synchronous modulation).	

C004 Silent Modulation

C004	Range	0-1	0: [No]; 1: [Yes]
	Default	See Table 81 and Table 85	
	Level	ENGINEERING	
	Address	1004	
	Function	This parameter enables silent modulation. The electric noise due to the switching frequency is dampened.	

34. MOTOR CONFIGURATION MENU

34.1. Overview

The Sinus Penta allows configuring three different types of motors and three different types of control algorithms at the same time.

The three types of control algorithms are identified with the acronyms

- ✓ **IFD** (Voltage/Frequency Control);
- ✓ **VTC** (Vector Torque Control);
- ✓ **FOC** (Field Oriented Control).

The **Voltage/Frequency control** allows controlling the motor by producing voltage depending on frequency.

The **Vector Torque Control (sensorless)** processes the machine equations depending on the equivalent parameters of the asynchronous machine. It also allows separating torque control from flux control with no need to use a transducer.

The **Field Oriented Control** is a closed-chain control requiring a speed transducer to detect the position of the motor shaft instant by instant.

The parameter set for the selected motor is included in the Motor Control menu:

- ✓ Motor Control 1 Menu concerns motor 1;
- ✓ Motor Control 2 Menu concerns motor 2;
- ✓ Motor Control 3 Menu concerns motor 3.

Factory setting allows configuring only one motor. To access the Configuration menus of the other connected motors, simply enter the number of the selected motor in **C009** (Number of Configured Motors) in the Motor Control 1 Menu.

To select the connected motor, use digital inputs programmed with parameters **C173** and **C174**, Digital Input for Motor 2 Activation and Digital Input for Motor 3 Activation respectively (see also the DIGITAL INPUTS MENU).

The parameters included in the Motor Control Menus are detailed in the table below.

Table 72: Description of the parameters classified by motor

Parameter Contents	Motor Control 1	Motor Control 2	Motor Control 3
Mains rated voltage	C008	_____	_____
Control algorithm being used	C010	C053	C096
Type of reference being used (speed/torque) (see Torque Control (VTC and FOC Only)	C011	C054	C097
Availability of the speed feedback from encoder	C012	C055	C098
Electric ratings of the motor	C015 ÷ C025	C058 ÷ C068	C101 ÷ C111
Max. speed and min. speed required, field weakening speed, field weakening time constant, max. speed alarm threshold and enable	C028 ÷ C031	C071 ÷ C074	C114 ÷ C117
V/f pattern parameters	C013/C032 ÷ C038	C056/C075 ÷ C081	C099/C118 ÷ C124
Slip compensation activation	C039	C082	C125
Drop in rated current voltage	C040	C083	C126
Fluxing ramp time	C041	C084	C127

The parameters that can be modified depend on the type of control that has been selected.

34.1.1. ELECTRICAL SPECIFICATIONS OF THE CONNECTED MOTOR

This group of parameters can be divided into two subunits: the first subunit includes the motor ratings, the second subunit includes the parameters of the equivalent circuit of the asynchronous machine being used.

34.1.2. MOTOR RATINGS

Table 73: Motor ratings

Motor Ratings	Motor 1	Motor 2	Motor 3
Rated frequency	C015	C058	C101
Rated rpm	C016	C059	C102
Rated power	C017	C060	C103
Rated current	C018	C061	C104
Rated voltage	C019	C062	C105
No-load power	C020	C063	C106
No-load current	C021	C064	C107

34.1.3. PARAMETERS OF THE EQUIVALENT CIRCUIT OF THE ASYNCHRONOUS MACHINE

Table 74: Parameters of the equivalent circuit of the asynchronous machine

Description	Motor 1	Motor 2	Motor 3
Stator resistance	C022	C065	C108
Leakage inductance	C023	C066	C109
Mutual inductance	C024	C067	C110
Rotor time constant	C025	C068	C111

Figure 42: Equivalent circuit of the asynchronous machine

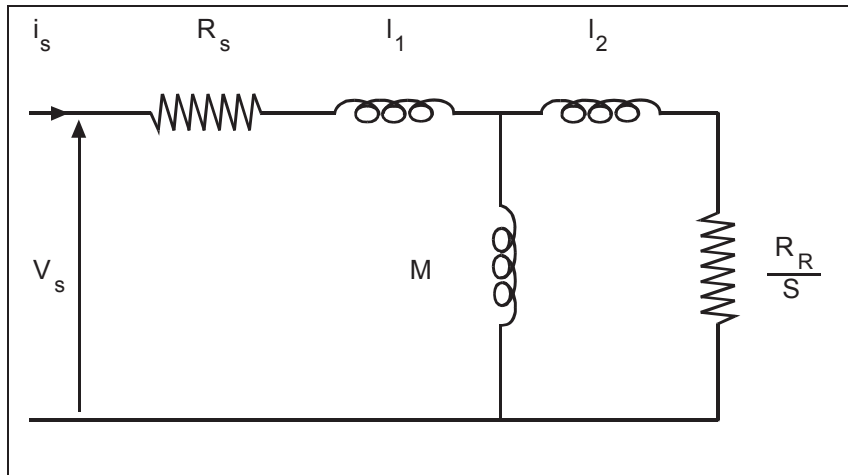

Where:

- R_s: Stator resistance (wires included)
- R_r: Rotor resistance
- l₁+l₂: Full leakage inductance
- M: Mutual inductance (not required for control implementation)
- S: Slip
- $\tau_{rot.} \cong M / R_r$ rotor time constant.

Because the motor characteristics are generally unknown, the Sinus Penta is capable of automatically determining the motor characteristics (see the FIRST STARTUP section and the AUTOTUNE MENU). However, some parameters may be manually adjusted to meet the requirements needed for special applications.

The parameters used for the different control algorithms are stated in the table below.

Table 75: Motor parameters used by control algorithms

Parameter	IFD	VTC	FOC
Stator resistance	v	v	v
Leakage inductance	—	v	—
Mutual inductance	—	v	v
Rotor time constant	—	v	v

v Used ; — Not used



NOTE

Because the value of the stator resistance is used for any type of control, always perform the autotune procedure with **I073** = Motor Tune and **I074** = 0: Motor Params.

34.1.4. V/F PATTERN (IFD ONLY)

This group of parameters which is included in the **Motor Control Menu** defines the V/f pattern trend of the drive when it is used as an IFD control algorithm. When setting the type of V/f pattern (e.g. **C013** for motor 1), the following curves can be used:

- Constant torque
- Quadratic
- Free setting

The diagram below illustrates three types of programmable curves compared to the theoretical V/f curve.

If **C013 = Constant Torque**, Preboost parameter **C034** allows changing the starting voltage value if compared to the theoretical V/f curve (this allows torque compensation for losses caused by the stator impedance and a greater torque at lower revs).

If **C013 = Quadratic**, the drive will follow a V/f pattern with a parabolic trend. You can set the starting voltage value (**C034**), the desired voltage drop if compared to the relevant constant torque (use **C032**) and the frequency allowing implementing this torque reduction (use **C033**).

If **C013 = Free Setting**, you can program the starting voltage (**C034 Preboost**), the increase in voltage to 1/20 of the rated frequency (**C035 Boost0**), and the increase in voltage (**C036 Boost1**) at programmable frequency (**C037 Frequency for Boost1**).

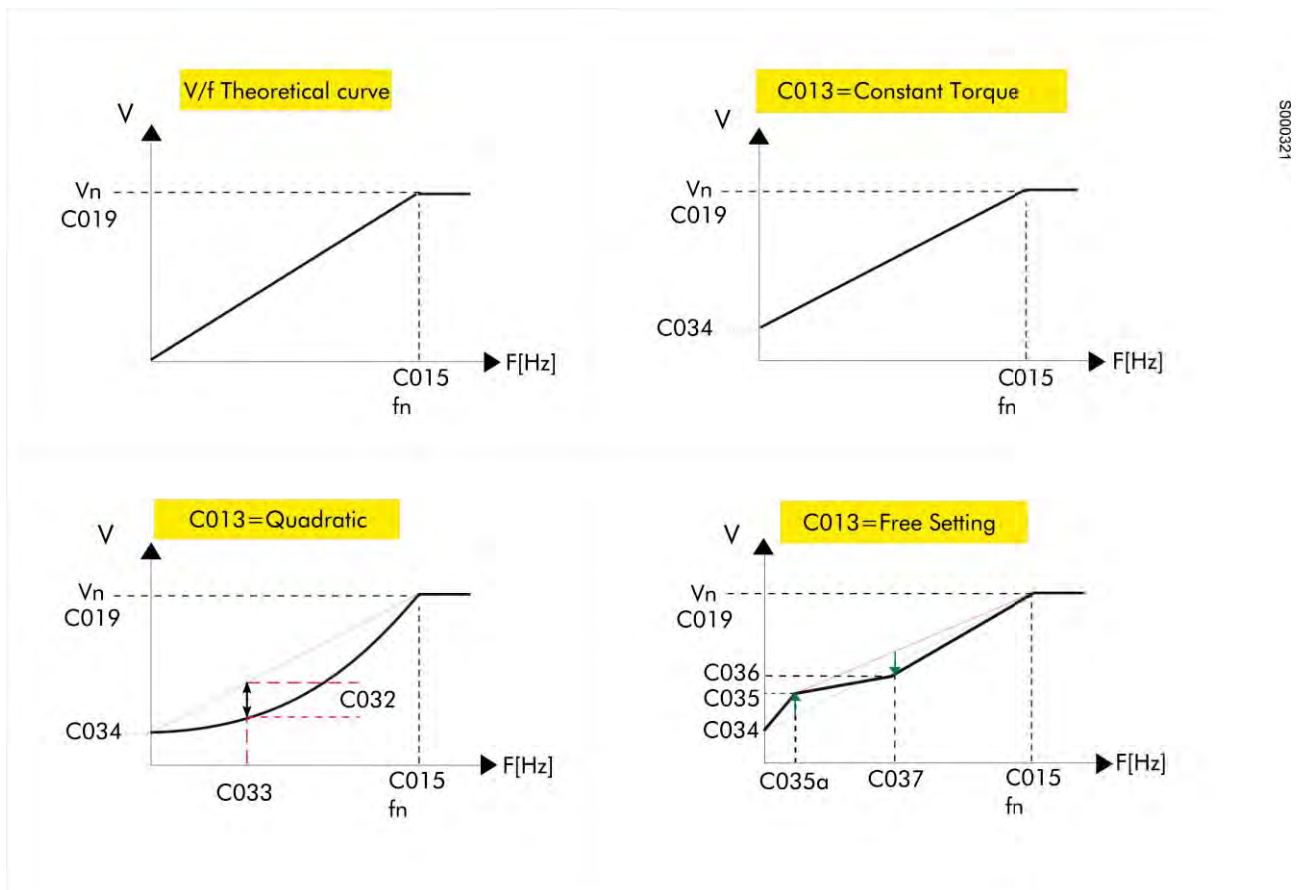

Figure 43: Types of programmable V/f curves

The voltage produced by the drive may be changed also by setting the **Automatic increase in torque curve** parameter (**C038** for motor 1).

For the description of the parameters used in the figure above, see table below.

Table 76: IFD control parameters for the connected motors

Parameter	Motor 1	Motor 2	Motor 3
Rated frequency: Rated frequency of the connected motor (current rating).	C015	C058	C101
Rated voltage: rated voltage of the connected motor (voltage rating).	C019	C062	C105
V/f curve type: Type of V/f curve applied.	C013	C056	C099
Torque reduction with quadratic curve: Torque reduction using V/f quadratic curve.	C032	C075	C118
Rated speed referring to torque reduction with quadratic curve: Speed actuating the torque reduction using a quadratic curve.	C033	C076	C119
Voltage preboost: Determines the voltage produced by the drive at min. output frequency fomin.	C034	C077	C120
Voltage Boost 0: Determines the voltage variations in respect to the nominal voltage at the frequency set up by the relevant parameter.	C035	C078	C121
Boost 0 application frequency: Determines the Boost 0 application frequency.	C035a	C078a	C121a
Voltage Boost 1: Determines the frequency for the application of the boost at preset frequency.	C036	C079	C122
Boost 1 application frequency: Determines the Boost 1 application frequency at preset frequency.	C037	C080	C123
Autoboost: Variable torque compensation expressed as a percentage of the rated motor voltage. The preset value expresses the voltage increase when the motor is running at rated torque.	C038	C081	C124

34.1.5. EXAMPLE 1 - V/F PATTERN PARAMETERIZATION

Motor 1: the voltage/frequency pattern is to be programmed for an asynchronous motor (400V/50Hz) with a rated speed of 1500rpm up to 2000rpm.

Type of V/f curve	C013	=	Constant Torque
Rated frequency	C015	=	50 Hz
Rated motor rpm	C016	=	1500rpm
Rated voltage	C019	=	400 V
Preboost	C034	=	depending on the starting torque
Max. speed	C029	=	2000rpm

34.1.6. EXAMPLE 2 - V/F PATTERN PARAMETERIZATION

The voltage/frequency pattern is to be programmed for an asynchronous motor (400V/50Hz) having a rated power of 7.5 kW and a rated speed of 1420 rpm with a voltage compensation depending on the motor torque:

Type of V/f pattern	C013	=	Constant Torque
Rated frequency	C015	=	50 Hz
Motor rpm	C016	=	1420rpm
Rated power	C017	=	7.5kW
Rated voltage	C019	=	400 V
Preboost	C034	=	depending on the starting torque
Autoboost	C038	=	4%

Voltage compensation (AutoBoost) results from the formula below:

$$\Delta V = C019 \times (C038/100) \times (T/Tn)$$

Where T is the estimated motor torque and Tn is the rated motor torque.

Tn is calculated as follows:

$$Tn = (Pn \times \text{pole pairs} / 2\pi f) = (C017 \times \text{pole pairs}) / (2\pi \times C015)$$

“Pole pairs” is the integer number obtained by rounding down (60* C015/C016).

The programmable parameters relating to the AutoBoost functions are the following:

C038 (AutoBoost): variable torque compensation expressed as a percentage of the motor rated voltage (**C019**). The value set in **C038** is the voltage increase when the motor is running at its rated torque.

C017 (Pn): rated power of the connected motor.

34.1.7. SLIP COMPENSATION (IFD ONLY)

This function allows compensating the speed decrease of the asynchronous motor when the mechanical load increases (slip compensation). This is available for IFD control only.

The parameters relating to this function are included in the Motor Control Menu (Configuration Menu).

Table 77: Parameters setting Slip Compensation (IFD Control)

Parameter	Motor 1	Motor 2	Motor 3
Rated voltage: Rated voltage of the connected motor (voltage rating).	C019	C062	C105
No-load power: Power absorbed by the motor when no load is connected to the motor; it is expressed as a percentage of the motor rated power.	C020	C063	C106
Stator resistance: Determines the resistance of the stator phases used to compute the power consumption due to Joule effect.	C022	C065	C108
Activation of slip compensation: If other than zero, this parameter enables slip compensation and defines its relevant value.	C039	C082	C125

Once the drive output power has been estimated and the power losses due to the Joule effect and to the mechanical parts (depending on output voltage and no-load power) have been subtracted, mechanical power is obtained. Starting from mechanical power and the value set for slip compensation (**C039** for motor 1), you can obtain the increase of the output frequency limiting the error between the desired speed value and the actual speed value of the connected motor.

34.1.8. TORQUE CONTROL (VTC AND FOC ONLY)

VTC and FOC controls allow controlling the drive with a torque reference instead of a speed reference. To do so, set [1: Torque or 2: Torque with Speed Limit [FOC only] in the relevant parameter (**C011** for motor 1, **C054** for motor 2, **C097** for motor 3).

In this way, the main reference corresponds to the motor torque demand and may range from **C047** to **C048 (Limits Menu)** for motor 1 (minimum and maximum torque expressed as a percentage of the motor rated torque). For motors 2 and 3, the parameters relating to min. and max. torque (**C090**, **C091** and **C133**, **C134**) are included in the Limits Menu 2 and Limits Menu 3.

Using a 0020 drive connected to a 15kW motor, **C048** is factory-set to 120% of the motor rated torque. If the max. reference is applied (**C143** = REF), the torque reference will be 120%.

If a 7.5kW motor is connected, **C048** may exceed 200%; torque values exceeding 200% may be obtained based on the value set in **C048**.

The motor rated torque results from the following formula:

$$C = P / \omega$$

where P is the rated power expressed in W and ω is the rated speed of rotation expressed in radians/sec.

Example: the rated torque of a 15kW motor at 1420rpm is equal to:

$$C = \frac{15000}{1420 \cdot 2\pi / 60} = 100.9 \text{ Nm}$$

The starting torque is:

$$\text{rated torque} * 120\% = 121.1 \text{ Nm}$$

34.1.9. TORQUE FOLLOWER MODE (VTC AND FOC ONLY)

If the torque reference mode is set, the VTC and FOC controls allow enabling the Torque Follower mode by activating parameter **C011c** (**C054c** for motor 2, **C097c** for motor 3). This allows the following:

- The inverter tracks the torque reference when the Enable input is closed, regardless of the Start input logics;
- No ramp is applied to the torque reference.

This mode is useful to get Master/Slave systems, where:

- A Master motor is driven by a drive in speed reference mode. This makes the instant torque demand value available externally to the drive (typically to an analog input).
- One or multiple Slave motors are driven by drives in torque reference mode and Torque Follower Mode, that get the torque reference from the Master, and that deliver the same torque as the Master's instant by instant.

Programming example of a Master/Slave system:

Master drive:

The Master drive will make the Torque Demand measure available to analog output AO1. The following are to be set in the ANALOG AND FREQUENCY OUTPUTS MENU (the parameters left at their default values are highlighted in gray):

P176	AO1: Representation Mode Selection	1: +/-10V
P177	AO1: Represented Variable Selected	64: Torque Dem. %
P178	AO1: Minimum Value of the Represented Variable	-200%
P179	AO1: Maximum Value of the Represented Variable	200%
P182	AO1: Output Value Corresponding to the Minimum Value	-10.0V
P183	AO1: Output Value Corresponding to the Maximum Value	10.0V

Values in **P178**, **P179** relate to the rated torque. In order for the output voltage range (-10 ÷ +10V) to correspond to the whole available torque range, values in **P178**, **P179** are to be the same as the values set for the torque limits in the LIMITS MENU:

C047	Minimum Torque for Motor 1	-200%
C048	Maximum Torque for Motor 1	200%

Slave Drive:

Analog output AO1 in the Master drive is connected to analog input AIN1 in the Slave drive. The input voltage range is to be the same as the torque range. The following are to be set up in the INPUTS FOR REFERENCES MENU:

P055	Type of Reference for AIN1 Input	0: +/-10V
P059	Filter Constant for AIN1 Input	0

The remaining parameters are to be left to their default values. In the LIMITS MENU, the torque limit values are to be the same as the Master's:

C047	Minimum Torque for Motor 1	-200%
C048	Maximum Torque for Motor 1	200%

Set the following in the MOTOR CONFIGURATION MENU:

C011	Type of Reference for M1	1: Torque
C011c	Torque Follower Mode	1: Yes

34.1.10. FIELD WEAKENING (VTC AND FOC ONLY)

When operating in field weakening mode, the asynchronous motor runs at a higher speed than its rated speed.

In field weakening mode, it is required to limit mechanical power not to exceed the motor ratings. In FOC and VTC mode, the maximum motor torque is limited as detailed in the LIMITS MENU based on the external torque limit (defined in the CONTROL METHOD MENU) and on the torque limit defined by parameters **C047/C048**.

Also, the field weakening mode requires limiting the maximum voltage required to the motor, mainly due to the back electromotive force, depending on the motor flux and the electric frequency. When in field weakening mode, the motor flux is to be properly reduced in order to limit output voltage.

Output voltage **M027** must be lower than the rated motor voltage (**C019**) not to exceed the motor ratings—at DC bus Vdc (**M029**) actually available—and not to introduce voltage harmonic distortion and current distortion. The phase-to-phase RMS voltage actually available is $V_{dc}/\sqrt{2}$.

Two field weakening modes are available for the FOC and VTC control modes, that may be activated also simultaneously:

- *“static” field weakening*: configured via parameter **C030** (field weakening speed).

If **C030** = “0: Disable”, the static field weakening is disabled.

If **C030** > 0, the magnetization current is decreased in respect to the rated value set in **C021** with inversely proportional pattern to speed ($1/n$) at a speed higher than the rated speed (**C016**) scaled by **C030**. For example, a motor featuring rated speed **C016**=1480rpm and **C030**=100%, with rated current **C018** =100A and **C021** = 25%, up to 1480rpm, the magnetization current is **C018** * **C021** = 100A * 25% = 25A; at 3000rpm the magnetization current is reduced by **C018** * **C021** / 3000 * (**C106** * **C030**) = 12.3A

- *“automatic” field weakening*: configured via parameter **C030a** (field weakening time constant).

If **C030a** = “0: Disable”, the automatic field weakening is disabled.

If **C030a** > 0, the magnetization current and flux **M017** are automatically decreased so that output voltage **M027** is lower than the rated motor voltage (**C019**) both at DC-link voltage divided by $\sqrt{2}$ and scaled by **C042**. In case the motor voltage exceeds the limits above, the automatic field weakening reduces the magnetization current until the output voltage equals the voltage limit.

The static field weakening is promptly activated based on a fixed magnetization current/speed relation, whilst the automatic field weakening dynamically adjusts the magnetization current with longer response time. When the operating conditions of the motor, e.g. the load torque, vary, the motor parameters depending on temperature and the DC-link voltage, the output voltage required to the motor and available to the motor vary accordingly. The automatic field weakening automatically adjusts the magnetization current to fit the motor operating conditions and enhancing output voltage.

NOTE

In VTC mode, when the motor is stalled in field weakening mode, set **C030** = “0: Disable” to allow for the activation of the automatic field weakening only.

The static field weakening is inactive by default, while the automatic field weakening is enabled by default.

The figure below shows the magnetization current (I_{mag}) pattern and the output voltage (V_{out}) pattern based on speed, with fixed load, for the static field weakening and the automatic field weakening.

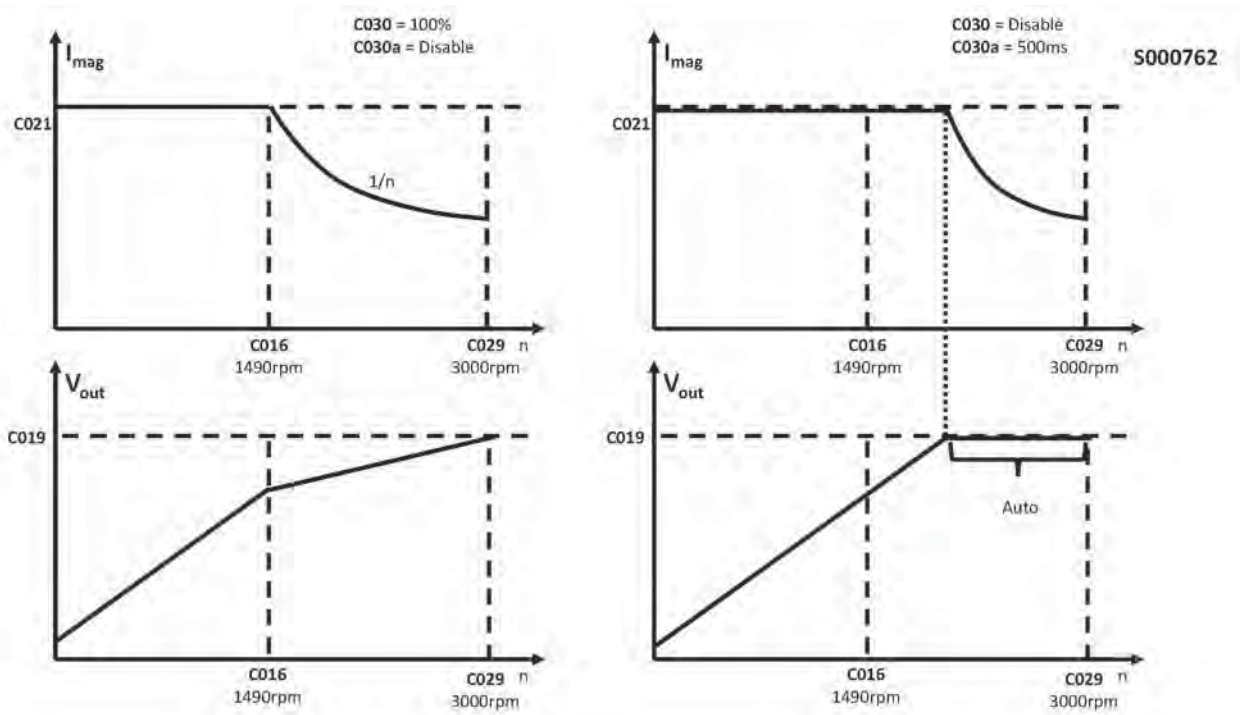

Figure 44: Comparing the static field weakening to the automatic field weakening

The parameters affecting field weakening operation are the following:

- Field Weakening Speed **C030**
- Field Weakening Time Constant **C030a**
- No-load Current **C021**
- Rotor Time Constant **C025**

The parameters above may be adjusted based on the following:

<i>Failure</i>	<i>What to do</i>
The motor is not capable of reaching the speed reference ("Limit St. Speed" displayed and the "Limit" LED comes ON on the display; "L" displayed on the 7-segment display)	Change one or more of the following parameters: A) Enable automatic field weakening by setting C030a >0. B) Decrease speed activating static field weakening C030 . C) Decrease no-load current C021 .
During acceleration ramps in field weakening mode, current limit activates (the "Limit" LED comes ON on the display and "H" is displayed on the 7-segment display). The motor is not capable of performing quick acceleration ramps in field weakening mode.	This means that field weakening is not responsive as required. Do the following: A) Enable automatic field weakening by setting C030a >0. If activated, this means that the time constant set in C030a is too long, so decrease C030a to increase responsiveness of the automatic field weakening mode. B) Decrease the speed value activating static field weakening C030 . C) Decrease no-load current C021 .
Too high current required to deliver motor torque (the "Limit" LED comes ON on the display and "H" is displayed on the 7-segment display), or the maximum deliverable torque in field weakening mode is too low.	This means that the magnetizing current in field weakening mode is too low. Do the following: A) Increase C030 in order to start reducing the magnetization current as 1/n at higher speed, or disable the static field weakening (C030 = "Disable"). When C030a >0, the automatic field weakening dynamically reduces the magnetization current, only if required. B) Increase no-load current C021 in order to increase the motor flux.
In field weakening mode, output voltage M027 is lower than the rated voltage and the DC-link voltage divided by $\sqrt{2}$.	This means that the magnetization current in field weakening mode is too low, so field weakening is excessive for the motor. This affects the maximum deliverable torque. Do the following: A) Increase C030 , because the speed value causing the magnetization current to decrease is too low, or disable static field weakening by setting C030 =Disable. B) Increase no-load current C021 .
In field weakening mode, speed, torque or current oscillations occur.	This means that the automatic field weakening is too jerky. Do the following: A) Increase time constant C030a . B) Decrease the activation speed for the static field weakening C030 , so that the automatic field weakening activates less frequently. C) Decrease no-load current C021 , so that the automatic field weakening activates less frequently.
Output voltage M027 required at high torque is lower than the no-load voltage (or at low torque), or is different than the expected torque based on the rated motor voltage.	This means that the motor flux is weak. This will affect the maximum deliverable torque. Do the following: A) Change rotor time constant C025 . B) Disable the static field weakening by setting C030 = "Disable" (or increase its value)

34.2. List of Parameters C008 to C128

Table 78: List of Parameters C008 to C128

Parameter	FUNCTION	User Level	MODBUS Address	DEFAULT VALUES
C008	Rated mains voltage	BASIC	1008	2:[380÷480V]
C009	N. of configured motors	ENGINEERING	1009	1

Parameter	FUNCTION	User Level	MODBUS Address	DEFAULT VALUES
C010 M1	Type of control algorithm	BASIC	1010	0: IFD
C053 M2			1053	
C096 M3			1096	
C011 M1	Type of reference	ADVANCED	1011 bit 0	0: Speed (MASTER mode)
C054 M2			1054 bit 0	
C097 M3			1097 bit 0	
C011c M1	Torque Follower mode	BASIC	1012 bit 1	0: No
C054c M2			1055 bit 1	
C097c M3			1098 bit 1	
C012 M1	Speed feedback from encoder	BASIC	1012	0: No
C055 M2			1055	
C098 M3			1098	
C013 M1	Type of V/f curve	BASIC	1013	See Table 84 and Table 88
C056 M2			1056	
C099 M3			1099	
C014 M1	Phase rotation	ENGINEERING	1014	0: No
C057 M2			1057	
C100 M3			1100	
C015 M1	Rated motor frequency	BASIC	1015	50.0 Hz
C058 M2			1058	
C101 M3			1101	
C016 M1	Rated motor rpm	BASIC	1016	1420 rpm
C059 M2			1059	
C102 M3			1102	
C017 M1	Rated motor power	BASIC	1017	See Table 85 and Table 89
C060 M2			1060	
C103 M3			1103	
C018 M1	Rated motor current	BASIC	1018	See Table 85 and Table 89
C061 M2			1061	
C104 M3			1104	
C019 M1	Rated motor voltage	BASIC	1019	Depending on the drive voltage class
C062 M2			1062	
C105 M3			1105	
C020 M1	Motor no-load power	ADVANCED	1020	0.0%
C063 M2			1063	
C106 M3			1106	
C021 M1	Motor no-load current	ADVANCED	1021	0%
C064 M2			1064	
C107 M3			1107	
C022 M1	Motor stator resistance	ENGINEERING	1022	See Table 85 and Table 89
C065 M2			1065	
C108 M3			1108	



Parameter	FUNCTION	User Level	MODBUS Address	DEFAULT VALUES
C023	Leakage inductance	ENGINEERING	1023	See Table 85 and Table 89
C066			1066	
C109			1109	
C024	Mutual inductance	ADVANCED	1024	250.00mH
C067			1067	
C110			1110	
C025	Rotor time constant	ADVANCED	1025	0 ms
C068			1068	
C111			1111	
C026	Time constant of bus voltage low-pass filter	ENGINEERING	1026	0 ms
C069			1069	
C112			1112	
C028	Min. motor speed	BASIC	1028	0 rpm
C071			1071	
C114			1114	
C029	Max. motor speed	BASIC	1029	1500 rpm
C072			1072	
C115			1115	
C030	Field weakening speed	ENGINEERING	1030	0: Disabled
C073			1073	
C116			1116	
C030a	Field weakening time constant	ENGINEERING	1137	500ms
C073a			1138	
C116a			1139	
C031	Max. speed alarm	ADVANCED	1031	0: Disabled
C074			1074	
C117			1117	
C032	Reduction in quadratic torque curve	ADVANCED	1032	30%
C075			1075	
C118			1118	
C033	Rated revs referring to reduction in quadratic torque curve	ADVANCED	1033	20%
C076			1076	
C119			1119	
C034	Voltage Preboost for IFD	BASIC	1034	See Table 83 and Table 87
C077			1077	
C120			1120	
C035	Voltage Boost 0 at programmable frequency	ADVANCED	1035	See Table 83 and Table 87
C078			1078	
C121			1121	
C035a	Frequency for Boost 0 application	ADVANCED	1052	5%
C078a			1070	
C121a			1113	
C036	Voltage Boost 1 at programmable frequency	ADVANCED	1036	See Table 83 and Table 87
C079			1079	
C122			1122	
C037	Frequency for application of voltage Boost 1	ADVANCED	1037	See Table 83 and Table 87
C080			1080	
C123			1123	
C038	Autoboost	ADVANCED	1038	See Table 83 and Table 87
C081			1081	
C124			1124	
C039	Slip compensation	ADVANCED	1039	0: Disabled

C082	M2			1082	
C125	M3			1125	
C040	M1			1040	
C083	M2	Voltage drop at rated current	ADVANCED	1083	0: Disabled
C126	M3			1126	

Parameter		FUNCTION	User Level	MODBUS Address	DEFAULT VALUES
C041	M1	Fluxing ramp time	ENGINEERING	1041	See Table 82 and Table 86
C084	M2			1084	
C127	M3			1127	
C042	M1	Vout saturation percentage	ENGINEERING	1042	100%
C085	M2			1085	
C128	M3			1128	

C008 Rated Mains Voltage

C008	Range	0 ÷ 8	0: [200 ÷ 240] V 1: 2T Regen. 2: [380 ÷ 480] V 3: [481 ÷ 500] V 4: 4T Regen. 5: [500 ÷ 600] V 6: 5T Regen. 7: [600 ÷ 690] V 8: 6T Regen.
	Default	2	2: [380 ÷ 480] V
	Level	BASIC	
	Address	1008	
	Function	This parameter defines the rated voltage of the mains powering the drive, thus allowing obtaining voltage ranges to be used for the drive operation. The value set in this parameter depends on the Drive voltage class . To supply the drive via a non-stabilized DC source, the corresponding AC voltage range must be used (see Table 79). DO NOT USE xT Regen settings in this case.	

Table 79: Equivalence between AC mains range and DC range

AC Mains	DC range
200÷240 Vac	280÷338 Vdc
380÷480 Vac	530÷678 Vdc
481÷500 Vac	680÷705 Vdc
500÷600 Vac	705÷810 Vdc
600÷690 Vac	810÷970 Vdc



NOTE

Select xT Regen (where x relates to the voltage class of the drive) **if the drive is DC-supplied through a regenerative Sinus Penta or a different drive used to stabilize the DC bus to a higher level than the stabilization level obtained when rectifying the 3-phase mains.**

C009 N. of Configured Motors

C009	Range	1÷3	1÷3
	Default	1	1
	Level	ENGINEERING	
	Address	1009	

	Function	<p>This parameter determines the number of motors to be configured. The active motor is selected through digital inputs programmed with C173 and C174 (see the DIGITAL INPUTS MENU).</p> <p>The programming parameters of the Motor Control 2 Menu can be accessed only if C009 = 2 or 3; the programming parameters of the Motor Control 3 Menu can be accessed only if C009 =3.</p>
--	-----------------	---

C010 (C053, C096) Type of Control Algorithm

C010 (Motor 1) C053 (Motor 2) C096 (Motor 3)	Range	0 ÷ 2	0: IFD 1: VTC 2: FOC
	Default Level	0	0: IFD
	Address	1010 1053 1096	
	Function	<p>This parameter sets the type of control algorithm to be used.</p> <p>Type of controls: 0: IFD V/f control 1: VTC Sensorless Vector Torque control 2: FOC Field Oriented Control</p> <p>The V/f control (IFD) allows controlling the motor by producing voltage depending on frequency. It is possible to configure several types of V/f patterns (see V/f Pattern (IFD Only)).</p> <p>The Sensorless Vector Control (VTC) and Field Oriented Control (FOC) are field-oriented control modes.</p> <p>The FOC is a closed-loop control, so a speed transducer is required to detect the position of the shaft of the connected motor.</p> <p>The VTC is a control mode w/out speed feedback, so no position/speed transducer is required: based on a dynamic model of an asynchronous motor, the algorithm estimates the speed and orientation of the motor flux.</p> <p>Both controllers guarantee segregation between the flux control and the torque control. In that way, the motor flux is adjusted based on the magnetizing current, obtained from No-load current C021 (C064 for motor 2 and C107 for motor 3).</p> <p>When the VTC or FOC controls are used, the connected motor can be controlled either via a torque reference or via a speed reference; in that case, the speed control loop, based on the error between reference speed and measured speed (FOC) or the estimated speed (VTC) is the external control loop for the torque controller.</p> <p>The equations used for VTC and FOC control algorithms require the following equivalent parameters of the asynchronous device: stator resistance C022 (C065 for motor 2, C108 for motor 3), mutual inductance C024 (C067 for motor 2, C110 for motor 3) and rotor time constant C025 (C068 for motor 2, C111 for motor 3). As per VTC, the following value is required leakage inductance C023 (C066 for motor 2 and C109 for motor 3).</p>	



NOTE FOC control requires a speed transducer, such as an encoder feedback.



CAUTION It is not advisable to set VTC and FOC algorithms with a nominal current motor lower than 50% of the drive model, otherwise the control performance is not guaranteed.

C011 (C054, C097) Type of Reference (Master/Slave)

C011 (Motor 1) C054 (Motor 2) C097 (Motor 3)	Range	0 ÷ 2	0: Speed (MASTER mode) 1: Torque (SLAVE mode) 2: Torque with speed limit (SLAVE mode) (FOC only)
	Default	0	0: Speed (MASTER mode)
	Level	ADVANCED	
	Address	1011, 1054, 1097	
	Control	VTC and FOC	
	Function	<p>This parameter defines the type of reference to be used. The torque control may be set up (see section Torque Control (VTC and FOC Only) as well).</p> <p>When the Torque control with speed limit mode is used, the drive will limit the motor rotation to the rpm set in parameter C029 (C072, C115).</p> <p>This function can be used to automatically toggle from the torque control mode to the speed control mode: when the torque control mode is implemented, the motor speed can reach any value included in the "AB" area (see figure below). If the limit speed is attained due to particular load conditions, the drive will automatically switch to the speed control ("BC" zone). The controlled torque is no longer maintained.</p> <p>If the torque returns to its setpoint value, the drive will automatically switch to the torque control again ("AB" zone).</p>	

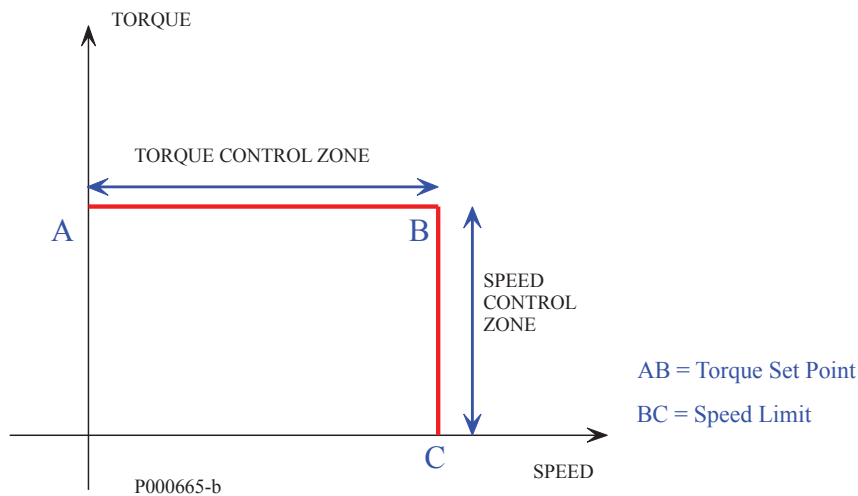

Figure 45: Torque control with speed limit



NOTE Mode 2 can be selected only if a FOC control is implemented.

C011c (C054c, C097c) Torque Follower Mode

C011c (mot. n.1) C054c (mot. n.2) C097c (mot. n.3)	Range	0 ÷ 1	0: No 1: Yes
	Default	0	0: No
	Level	BASIC	
	Address	1012, 1055, 1098 bit 0	
	Control	VTC and FOC	
	Function	The Torque Follower mode activates when this parameter is enabled. If the drive is in torque reference mode (parameter C011 = 1 or 2, or activation of the input set in C170), it will follow the torque reference without applying any ramp and without being dependent on the Start input logics. Just close the Enable input to let the drive track the given reference.	

C012 (C055, C098) Speed Feedback from Encoder

C012 (Motor 1) C055 (Motor 2) C098 (Motor 3)	Range	0 ÷ 1	0: No 1: Yes
	Default	0	0: No
	Level	BASIC	
	Address	1012, 1055, 1098 bit 1	
	Control	VTC and FOC	
	Function	This parameter enables the encoder as a speed feedback. It defines the encoder characteristics and whether Encoder A (MDI6 and MDI7 in the terminal board) or Encoder B (with optional board) is used as a speed feedback (see the ENCODER/FREQUENCY INPUTS MENU).	



NOTE

Parameters **C011c** and **C012** (and **C054/C054c** (motor 2) and **C097/C097c** (motor 3).) may have binary values only and they share the same Modbus address. The bit-parameter match is given in the Table 80.

It is important to consider this if the address is updated from an external interface system: before writing a new value, read the address value and change the bit concerned only, to avoid changing the other parameter as well.

These precautions are not necessary for the changes made via keypad or RemoteDrive.

Table 80: Coding of Parameters C011c (C054c, C097c) and C012 (C055, C098)

bit [15..2]	bit [1]	bit [0]
Not used	C011c (C054c , C097c)	C012 (C055 , C098)

C013 (C056, C099) Type of V/F Pattern

C013 (Motor 1) C056 (Motor 2) C099 (Motor 3)	Range	0 ÷ 2	0: Constant Torque 1: Quadratic 2: Free Setting
	Default	See Table 83 and Table 87	
	Level	BASIC	
	Address	1013, 1056, 1099	
	Control	IFD	
	Function	<p>Allows selecting different types of V/f pattern.</p> <p>If C013 (C056,C099) = Constant torque, voltage at zero frequency can be selected (Preboost C034 (C077,C120)).</p> <p>If C013 (C056,C099) = Quadratic, you can select voltage at zero frequency (preboost, C034 (C077,C120)), max. voltage drop with respect to the theoretical V/f pattern, C032 (C075 C118), and the frequency allowing implementing max. voltage drop, C033 (C076 C119).</p> <p>If C013 (C056,C099) = Free Setting, you can set voltage at zero frequency (preboost, C034(C077,C120)); voltage increase to 20% of the rated frequency (Boost0, C035 (C078,C121)); and voltage increase to a programmed frequency (Boost1, C036 (C079,C122)); frequency for Boost1, C037 (C080,C123)).</p>	

C014 (C057, C100) Phase Rotation

C014 (Motor 1) C057 (Motor 2) C100 (Motor 3)	Range	0÷1	0: [No]; 1: [Yes]
	Default	0	0: [No]
	Level	ENGINEERING	
	Address	1014, 1057,1100	
	Function	Allows reversing the mechanical rotation of the connected motor.	



DANGER!!!

When activating **C014 (C057, C100)**, the mechanical rotation of the connected motor and its load is reversed accordingly.

C015 (C058, C101) Rated Motor Frequency

C015 (Motor 1) C058 (Motor 2) C101 (Motor 3)	Range	10 ÷ 10000	1.0 Hz ÷ 1000.0 Hz
	Default	500	50.0 Hz
	Level	BASIC	
	Address	1015, 1058, 1101	
	Control	All	
	Function	This parameter defines the rated motor frequency (nameplate rating).	
	Function	See upper limits in Table 70	

C016 (C059, C102) Rated Motor Rpm

C016 (Motor 1) C059 (Motor 2) C102 (Motor 3)	Range	1 ÷ 32000	1 ÷ 32000 rpm
	Default	1420	1420 rpm
	Level	BASIC	



	Address	1016 , 1059, 1102
	Function	This parameter defines the rated motor rpm (nameplate rating).

C017 (C060,C103) Rated Motor Power

C017 (Motor 1) C060 (Motor 2) C103 (Motor 3)	Range	1 ÷ 32000	0.1 ÷ 3200.0 kW
		Upper limited to twice the default value	
	Default	See Table 84 and Table 88	
	Level	BASIC	
	Address	1017, 1060, 1103	
	Function	This parameter defines the rated motor power (nameplate rating).	

C018 (C061, C104) Rated Motor Current

C018 (Motor 1) C061 (Motor 2) C104 (Motor 3)	Range	1 ÷ 32000	0.1 ÷ 3200.0 A
		Upper limited to the values in Inom column in Table 81 and Table 85	
	Default	See Table 84 and Table 88	
	Level	BASIC	
	Address	1018 , 1061, 1104	
	Function	This parameter defines the rated motor current (nameplate rating).	

C019 (C062, C105) Rated Motor Voltage

C019 (Motor 1) C062 (Motor 2) C105 (Motor 3)	Range	50 ÷ 12000	5.0 ÷ 1200.0 V
		Default	2300 for class 2T drives 4000 for class 4T drives 5750 for class 5T drives 6900 for class 6T drives
	Level	BASIC	
	Address	1019 , 1062, 1105	
	Function	This parameter defines the rated motor voltage (nameplate rating).	

C020 (C063, C106) Motor No-Load Power

C020 (Motor 1) C063 (Motor 2) C106 (Motor 3)	Range	0 ÷ 1000	0.0 ÷ 100.0%
		Default	0
	Level	ADVANCED	
	Address	1020 , 1063, 1106	
	Function	This parameter defines the power absorbed by the motor at rated voltage and rated rpm when no load is connected to the motor.	

C021 (C064,C107) Motor No-Load Current

C021 (Motor 1) C064 (Motor 2) C107 (Motor 3)	Range	1 ÷ 100	1 ÷ 100%
	Default	0	0%
	Level	BASIC	
	Address	1021, 1064, 1107	
	Function	<p>This parameter defines the current absorbed by the motor at rated voltage and rated rpm when no load is connected to the motor. It is expressed as a percentage of the motor rated current C018 (C061, C104). For a proper tuning of the current loops required for FOC control, enter a value other than zero.</p> <p>If the stator resistance is tuned (1073 = [1: Motor Tune]; 1074 = [0: Motor Params]) and the no load current parameter is zero, a value for a first attempt is assigned to this parameter, depending on power and pole pairs of the connected motor.</p>	

C022 (C065, C108) Motor Stator Resistance

C022 (Motor 1) C065 (Motor 2) C108 (Motor 3)	Range	0 ÷ 32000	0.000 ÷ 32.000Ω
	Default	See Table 84 and Table 88	
	Level	ADVANCED	
	Address	1022, 1065, 1108	
	Function	<p>This parameter defines stator resistance Rs.</p> <p>If a star connection is used, it matches with the value of the resistance of one phase (half the resistance measured between two terminals); if a delta connection is used, it matches with 1/3 of the resistance of one phase.</p> <p>Autotune is always recommended.</p>	

C023 (C066, C109) Motor Leakage Inductance

C023 (Motor 1) C066 (Motor 2) C109 (Motor 3)	Range	0 ÷ 32000	0.00 ÷ 320.00mH
	Default	See Table 84 and Table 88	
	Level	ADVANCED	
	Address	1023, 1066, 1109	
	Function	<p>This parameter defines the global leakage inductance of the connected motor.</p> <p>If a star connection is used, it matches with the value of the inductance of one phase; if a delta connection is used, it matches with 1/3 of the inductance of one phase.</p> <p>Autotune is always recommended.</p>	



NOTE With the Autotune function, calculate the value of the leakage inductance (**C023**). From the resulting value, manually subtract the value in mH of the output inductance (if any).

C024 (C067, C110) Mutual Inductance

C024 (Motor 1) C067 (Motor 2) C110 (Motor 3)	Range	0 ÷ 65000	0.00 ÷ 650.00 mH
	Default	25000	250.00 mH
	Level	ADVANCED	
	Address	1024, 1067, 1110	
	Function	This parameter defines the mutual inductance of the connected motor. The approximate value of the mutual inductance results from no-load current I_0 and from stator resistance R_{stat} according to the formula below: $M \cong (V_{mot} - R_{stat} \times I_0) / (2\pi f_{mot} \times I_0)$	



NOTE

Parameter **C024** (mutual inductance) is **automatically calculated** based on the preset no-load current value (**C021**) whenever parameters **I073** and **I074** are set as follows:

I073 = [1: Motor Tune]

I074 = [0: Motor Params]

whether current loop tuning is performed or not.

C025 (C068, C111) Rotor Time Constant

C025 (Motor 1) C068 (Motor 2) C111 (Motor 3)	Range	0 ÷ 5000	0 ÷ 5000msec
	Default	0	
	Level	ADVANCED	
	Address	1025, 1068, 1111	
	Control	VTC and FOC	
	Function	This parameter defines the rotor time constant of the connected motor. If the rotor time constant is not stated by the motor manufacturer, it can be obtained through the autotune function (see the FIRST STARTUP section and the AUTOTUNE MENU).	



NOTE

Whenever one of these parameters is written, the drive automatically computes and saves the parameters of PI flux regulator and FOC control: proportional constant for motor 1 **P158** (**P165** for motor 2, **P172** for motor 3) and integral time **P159** (**P166** for motor 2, **P173** for motor 3).

C026 (C069, C112) Time Constant of Bus Voltage Low-pass Filter

C026 (Motor 1) C069 (Motor 2) C112 (Motor 3)	Range	0 ÷ 32000	0.0 ÷ 3200.0 ms
	Default	0	0.0 ms
	Level	ENGINEERING	
	Address	1026, 1069, 1112	
	Function	This parameter defines the time constant of the low-pass filter of the bus voltage readout. Changing this value can avoid motor oscillations, especially when no load is connected to the motor.	

C028 (C071, C114) Min. Motor Speed

C028 (Motor 1) C071 (Motor 2) C114 (Motor 3)	Range	-32000 ÷ 32000 (*)	-32000 ÷ 32000 rpm (*)
	Default	0	0 rpm
	Level	BASIC	
	Address	1028, 1071, 1114	
	Function	<p>This parameter defines the minimum speed of the connected motor. When references forming the global reference are at their min. relative value, the global reference equals the min. speed of the connected motor.</p> <p><i>Example:</i> CONTROL METHOD MENU C143 →[1: REF] Selection of reference 1 source C144 →[2: AIN1] Selection of reference 2 source C145 →[0: Disable] Selection of reference 3 source C146 →[0: Disable] Selection of reference 4 source</p> <p>INPUTS FOR REFERENCES MENU P050 →[0: ± 10V] Type of reference for REF input P051 →[- 10V] Value of the min. reference for REF input P052 →[+10V] Value of the max. reference for REF input P055 →[0: ± 10V] Type of reference for AIN1 input P056 →[- 5 V] Value of min. reference for AIN1 input P057 →[+5 V] Value of max. reference for AIN1 input</p> <p>The speed reference is the min. speed set in C028 (motor 1) when both REF input and AIN1 input values are lower than or equal to the minimum values set in P051 and P056 respectively.</p>	



(*) **NOTE**

The maximum allowable value (as an absolute value) for **C028** and **C029** (min. and max. motor speed) also depends on the preset **max. carrier frequency** (see Table 70). It can be max. 4 times the rated speed of the connected motor.



NOTE

The value set as the min. speed is used as the saturation of the global reference; the speed reference will never be lower than the value set as min. speed.



NOTE

The min. speed is not respected only when the REV command or the CW/CCW command are sent after setting a value for max. speed exceeding the min. value (**C029**>**C028** for motor 1) and with the max. reference to the drive. The motor rpm will be **-C029 <C028**.

C029 (C072, C115) Max. Motor Speed

C029 (Motor 1) C072 (Motor 2) C115 (Motor 3)	Range	0 ÷ 32000 (*see note in parameter C028)	0 ÷ 32000 rpm (*see note in parameter C028)
	Default	1500	1500 rpm
	Level	BASIC	
	Address	1029, 1072, 1115	
	Function	<p>This parameter defines the maximum speed of the connected motor. When references forming the global reference are at their max. relative value, the global reference equals the max. speed of the connected motor.</p> <p>If C011 (C054, C097) = 2: Torque with speed limit, this parameter is used to limit the motor rotation.</p>	



NOTE

In the CONTROL METHOD MENU, if an external speed/torque limit source (**C147**) is selected, the speed limit value set with this parameter is the upper limit, that can be reduced by adjusting the external source. Also, the ramp times set in the RAMPS MENU (**P009–P025**) are applied to this limit.

C030 (C073, C116) Field weakening Start Speed

C030 (mot. n.1) C073 (mot. n.2) C116 (mot. n.3)	Range	0 ÷ 200	0: Disabled ÷ 200%
	Default	0	0: Disabled
	Level	ENGINEERING	
	Address	1030, 1073, 1116	
	Control	VTC e FOC	
	Function	<p>This parameter defines the speed value determining the motor field weakening based on 1/n (“static” <i>field weakening</i>).</p> <p>It is expressed as a percentage of the rated motor speed C016 (C059, C102). With C030 (C073, C116)=0: Disabled, the motor field weakening never occurs based on law 1/n.</p> <p>For more details, see Field Weakening (VTC and FOC Only).</p>	

C030a (C073a, C116a) Field Weakening Time Constant

C030a (mot. n.1) C073a (mot. n.2) C116a (mot. n.3)	Range	0 ÷ 32000	0: Disabled ÷ 32000ms
	Default	500	500ms
	Level	ENGINEERING	
	Address	1137, 1138, 1139	
	Control	VTC and FOC	
	Function	<p>With C030a (C073a, C116a)=other than 0: Disabled, the motor field weakening follows a law optimizing the output voltage based on the available DC voltage (“automatic” <i>field weakening</i>).</p> <p>This parameter defines the trip rate of the automatic field weakening regulator.</p> <p>For more details, see Field Weakening (VTC and FOC Only).</p>	

C031 (C074, C117) Max. Speed Alarm

C031 (Motor 1) C074 (Motor 2) C117 (Motor 3)	Range	0 ÷ 32000	0: (Disabled) ÷ 32000 rpm
	Default	0	0: Disabled
	Level	ADVANCED	
	Address	1031, 1074, 1117	
	Function	If it is not set to zero, this parameter determines the speed value to be entered for the maximum speed alarm (A076).	

C032 (C075, C118) Reduction in Quadratic Torque Curve

C032 (Motor 1) C075 (Motor 2) C118 (Motor 3)	Range	0 ÷ 1000	0 ÷ 100.0%
	Default	300	30.0%
	Level	ADVANCED	
	Address	1032, 1075, 1118	
	Control	IFD	
	Function	If the V/f curve pattern C013 (C056, C099) = Quadratic , this parameter defines the maximum voltage reduction in terms of theoretical V/f pattern, which is implemented at the frequency programmed in C033 (C076, C119) .	

C033 (C076, C119) Max. Reduction Frequency for Quadratic Torque Pattern

C033 (Motor 1) C076 (Motor 2) C119 (Motor 3)	Range	1 ÷ 100	1 ÷ 100%
	Default	20	20%
	Level	ADVANCED	
	Address	1033, 1076, 1119	
	Control	IFD	
	Function	If the V/f curve pattern C013 (C056, C099) = Quadratic , this parameter defines the frequency implementing the max. torque reduction in terms of theoretical V/f pattern set in C032 (C075, C120) .	

C034 (C077, C120) Voltage Preboost for IFD

C034 (Motor 1) C077 (Motor 2) C120 (Motor 3)	Range	0 ÷ 50	0.0 ÷ 5.0 %
	Default	See Table 83 and Table 87	
	Level	BASIC	
	Address	1034, 1077, 1120	
	Control	IFD	
	Function	Torque compensation at minimum frequency produced by the drive. IFD control: determines the increase of the output voltage at 0Hz.	

C035 (C078, C121) Voltage Boost 0 at Programmable Frequency

C035 (Motor 1) C078 (Motor 2) C121 (Motor 3)	Range	-100 ÷ +100	-100 ÷ +100 %
	Default	See Table 83 and Table 87	
	Level	ADVANCED	
	Address	1035, 1078, 1121	
	Control	IFD	
	Function	Torque compensation at preset frequency (parameter C035a for motor 1, C078a for motor 2 and C121a for motor 3). This parameter defines the output voltage variation at preset frequency in respect to the frequency resulting from the constant V/f ratio (voltage/frequency constant). It is expressed as a percentage of the nominal motor voltage (C019, C062, C105).	

C035a (C078a, C121a) Frequency for Boost 0 Application

C035a (mot. n.1) C078a (mot. n.2) C121a (mot. n.3)	Range	0 ÷ 99	0 ÷ 99 %
	Default	5	5%
	Level	ADVANCED	
	Address	1052, 1070, 1113	
	Control	IFD	
	Function	Frequency for the application of the boost preset with parameter C035 for motor 1, C078 for motor 2 and C121 for motor 3. It is expressed as a percentage of the nominal motor frequency (C015 , C058 , C101).	

C036 (C079, C122) Voltage Boost 1 at Programmable Frequency

C036 (Motor 1) C079 (Motor 2) C122 (Motor 3)	Range	-100 ÷ +400	-100 ÷ +400 %
	Default	See Table 83 and Table 87	
	Level	ADVANCED	
	Address	1036, 1079, 1122	
	Control	IFD	
	Function	Torque compensation at preset frequency (parameter C037 for motor 1, C080 for motor 2 and C123 for motor 3). Determines how output voltage varies at preset frequency with respect to voltage obtained with a constant V/f pattern (constant voltage frequency). It is expressed as a percentage of the nominal motor frequency (C019 , C062 , C105).	

C037 (C080, C123) Frequency for Boost 1 Application

C037 (Motor 1) C080 (Motor 2) C123 (Motor 3)	Range	6 ÷ 99	6 ÷ 99 %
	Default	See Table 83 and Table 87	
	Level	ADVANCED	
	Address	1037, 1080, 1123	
	Control	IFD	
	Function	Frequency for application of voltage Boost with parameter C036 for motor 1, parameter C079 for motor 2 and parameter C122 for motor 3. This is expressed as a percentage of the motor rated frequency (C015 , C058 , C101).	

C038 (C081, C124) Autoboot

C038 (Motor 1) C081 (Motor 2) C124 (Motor 3)	Range	0 ÷ 10	0 ÷ 10 %
	Default	See Table 83 and Table 87	
	Level	ADVANCED	
	Address	1038, 1081, 1124	
	Control	IFD	
	Function	Variable torque compensation expressed as a percentage of the motor rated voltage. The preset value expresses the voltage increase when the motor is running at its rated torque.	



NOTE For optimum efficiency, it is recommended that Autotune **I074=0** is performed, as the stator resistance value (**C022, C065, C108**) is used for the Autoboot function.

C039 (C082,C125) Slip Compensation

C039 (Motor 1) C082 (Motor 2) C125 (Motor 3)	Range	0 ÷ 200	[0: Disabled] ÷ 200 %
	Default	0	[0: Disabled]
	Level	ADVANCED	
	Address	1039, 1082, 1125	
	Control	IFD	
	Function	This parameter represents the motor rated slip expressed as a value percent. If set to 0, this function is disabled.	



NOTE For optimum efficiency, it is recommended that Autotune **I074=0** is performed, as the stator resistance value (**C022, C065, C108**) is used for the Slip Compensation function. The no-load power value is to be entered as well (**C020, C063, C106**).

C040 (C083, C126) Voltage Drop at Rated Current

C040 (Motor 1) C083 (Motor 2) C126 (Motor 3)	Range	0÷500	0÷50.0%
	Default	0	0:Disabled
	Level	ADVANCED	
	Address	1040, 1083, 1126	
	Control	IFD	
	Function	Defines the voltage increase required to compensate the voltage drop between the inverter and the motor due to the presence of a filter. The voltage increase is given by: $\Delta V = (C040/100) * V_{mot} * I_{out}/I_{mot} * f_{out}/f_{mot}$, where I_{out} is the output current, f_{out} is the output frequency, V_{mot} , I_{mot} and f_{mot} are the rated motor voltage, rated motor current and rated motor frequency respectively (parameters C019, C018 and C015). Example: C040 = 10% Voltage drop at rated current C013 = Constant Torque Type of V/f pattern C015 = 50 Hz Rated frequency C019= 380 V Rated voltage C018 = 50 A Rated current If the drive output frequency is 25 Hz, it should deliver 190V. When the output current is 40A (C018) the voltage actually produced is $V_{out} = 190 + ((10/100 * 380) * 40/50 * 25/50) = 190 + 15.2 = 205.2 V$.	

C041 (C084,C127) Fluxing Ramp Time

C041 (Motor 1) C084 (Motor 2) C127 (Motor 3)	Range	40 ÷ 4000	40 ÷ 4000 msec
	Default	See Table 82 and Table 86	
	Level	ENGINEERING	
	Address	1041, 1084, 1127	
	Control	VTC and FOC	

	Function	This parameter indicates the time spent for motor fluxing.
--	-----------------	--

C042 (C085, C0128) Vout Saturation Percentage

C042 (Motor 1) C085 (Motor 2) C128 (Motor 3)	Range	10 ÷ 120	10 ÷ 120 %
	Default	100	100%
	Level	ENGINEERING	
	Address	1042, 1085, 1128	
	Function	This parameter sets the bus voltage value percent used to generate the output voltage of the drive. Changes made to this parameter affect the motor performance in terms of field weakening.	

34.3. Tables Including the Parameters Depending on the Drive Model

34.3.1. VOLTAGE CLASS 2T/4T

Table 81: Parameters depending on the Drive Model - Class 2T/4T / 1

SIZE	MODEL	DRIVE INOM [A]	DRIVE IMAX [A]	DRIVE IPEAK [A]	DEF CARRIER [kHz]	MAX CARRIER [kHz]	DEF Silent Modulation
					C001 C002	C001 C002	C004
S05	0005	10.5	11.5	14	5	16	YES
	0007	12.5	13.5	16	5	16	YES
	0008	15	16	19	5	10	YES
	0009	16.5	17.5	19	5	16	YES
	0010	17	19	23	5	10	YES
	0011	16.5	21	25	5	16	YES
	0013	19	21	25	5	10	YES
	0014	16.5	25	30	5	16	YES
S05/S12	0015	23	25	30	5	10	YES
	0016	27	30	36	3	10	YES
S12	0020	30	36	43	3	10	YES
	0017	30	32	37	3	10	YES
	0023	38	42	51	3	10	YES
	0025	41	48	58	3	10	YES
	0030	45	56	67	3	10	YES
	0033	51	56	68	3	10	YES
	0034	57	63	76	3	10	YES
	0036	60	72	86	3	10	YES
S15	0037	65	72	83	3	10	YES
	0040	72	80	88	3	16	YES
S20	0049	80	96	115	3	12.8	YES
	0060	88	112	134	3	10	YES
	0067	103	118	142	3	10	YES
	0074	120	144	173	3	10	YES
S30	0086	145	155	186	3	10	YES
	0113	180	200	240	2	10	YES
	0129	195	215	258	2	10	YES
	0150	215	270	324	2	8	YES
S41	0162	240	290	324	2	8	YES
	0180	300	340	408	2	6	NO
	0202	345	420	504	2	6	NO
	0217	375	460	552	2	6	NO
	0260	445	560	672	2	6	NO

SIZE	MODEL	DRIVE INOM [A]	DRIVE IMAX [A]	DRIVE IPEAK [A]	DEF CARRIER [kHz]	MAX CARRIER [kHz]	DEF Silent Modulation
					C001 C002	C001 C002	C004
S51	0313	480	600	720	2	5	NO
	0367	550	680	792	2	5	NO
	0402	680	850	1020	2	5	NO
S60	0457	720	880	1056	2	4	NO
	0524	800	960	1152	2	4	NO
S60P	0598P	900	1100	1152	2	4	NO
S65	0598	900	1100	1320	2	4	NO
	0748	1000	1300	1560	2	4	NO
	0831	1200	1440	1728	2	4	NO
S75	0964	1480	1780	2136	2	4	NO
	1130	1700	2040	2448	2	4	NO
	1296	2100	2520	3024	2	4	NO
S90	1800	2600	3100	3720	2	4	NO
	2076	3000	3600	4000	2	4	NO
2xS41	0523	800	960	960	2	5	NO
2xS51	0599	900	1100	1100	2	5	NO
	0749	1000	1300	1300	2	5	NO
	0832	1200	1440	1440	2	5	NO
3xS51	0850	1340	1600	1600	2	5	NO
	0965	1480	1780	1780	2	5	NO
	1129	1700	2040	2040	2	5	NO

Table 82: Parameters depending on the Drive Model - Class 2T/4T / 2

SIZE	MODEL	DEF TFLUX [ms]	DEF ILIM DEC [%Inom]	DEF DCB RAMP [ms]	DEF Acc. Time [sec]	DEF Dec. Time [sec]	S – Acc/Dec DEF	Fire Mode Ramps DEF [sec]	UNIT Acc. / Dec. DEF [sec]	Dec. Ramp Ext. DEF
	M1	C041	C045	C222	P009	P010	P022	P032 P033	P014 P020	C210
	M2	C084	C088	C223	P012	P013	P023			
	M3	C127	C131	C224	P015 P018	P016 P019	P024 P025			
S05	0005	300	150	50	10	10	50	10	0.1	0.2
	0007	300	150	50	10	10	50	10	0.1	0.2
	0008	300	150	50	10	10	50	10	0.1	0.2
	0009	300	150	50	10	10	50	10	0.1	0.2
	0010	300	150	50	10	10	50	10	0.1	0.2
	0011	300	150	50	10	10	50	10	0.1	0.2
	0013	300	150	50	10	10	50	10	0.1	0.2
S05/S12	0014	300	150	50	10	10	50	10	0.1	0.2
	0015	300	150	50	10	10	50	10	0.1	0.2
S12	0016	300	150	50	10	10	50	10	0.1	0.2
	0020	300	150	50	10	10	50	10	0.1	0.2
	0017	300	150	50	10	10	50	10	0.1	0.2
	0023	300	150	50	10	10	50	10	0.1	0.2
	0025	300	150	50	10	10	50	10	0.1	0.2
	0030	300	150	50	10	10	50	10	0.1	0.2
	0033	300	150	50	10	10	50	10	0.1	0.2
S15	0034	300	150	70	10	10	50	10	0.1	0.2
	0036	300	150	70	10	10	50	10	0.1	0.2
	0037	300	150	70	10	10	50	10	0.1	0.2
	0040	300	150	70	10	10	50	10	0.1	0.2
S20	0049	300	150	80	10	10	50	10	0.1	0.2
	0060	300	150	80	10	10	50	10	0.1	0.2
	0067	300	150	100	10	10	50	10	0.1	0.2
	0074	300	150	100	10	10	50	10	0.1	0.2
S30	0086	300	150	150	10	10	50	10	0.1	0.2
	0113	300	150	150	10	10	50	10	0.1	0.2
	0129	300	150	150	10	10	50	10	0.1	0.2
	0150	300	150	200	10	10	50	10	0.1	0.2
S41	0162	300	150	200	10	10	50	10	0.1	0.2
	0180	450	100	250	100	100	1	100	1	2
	0202	450	100	250	100	100	1	100	1	2
	0217	450	100	250	100	100	1	100	1	2
	0260	450	100	250	100	100	1	100	1	2



SIZE	MODEL	DEF TFLUX [ms]	DEF ILIM DEC [%Inom]	DEF DCB RAMP [ms]	DEF Acc. Time [sec]	DEF Dec. Time [sec]	S – Acc/Dec DEF	Fire Mode Ramps DEF [sec]	UNIT Acc. / Dec. DEF [sec]	Dec. Ramp Ext. DEF
	M1	C041	C045	C222	P009	P010	P022	P032 P033	P014 P020	C210
	M2	C084	C088	C223	P012	P013	P023			
	M3	C127	C131	C224	P015	P016	P024			
S51	0313	450	100	250	100	100	1	100	1	2
	0367	450	100	250	100	100	1	100	1	2
	0402	450	100	250	100	100	1	100	1	2
S60	0457	450	100	250	100	100	1	100	1	2
	0524	450	100	250	100	100	1	100	1	2
S60P	0598P	450	100	250	100	100	1	100	1	2
S65	0598	450	100	250	100	100	1	100	1	2
	0748	450	100	250	100	100	1	100	1	2
	0831	450	100	250	100	100	1	100	1	2
S75	0964	450	100	250	100	100	1	100	1	2
	1130	450	100	250	100	100	1	100	1	2
	1296	450	100	250	100	100	1	100	1	2
S90	1800	450	100	250	100	100	1	100	1	2
	2076	450	100	250	100	100	1	100	1	2
2xS41	0523	450	100	250	100	100	1	100	1	2
2xS51	0599	450	100	250	100	100	1	100	1	2
	0749	450	100	250	100	100	1	100	1	2
	0832	450	100	250	100	100	1	100	1	2
3xS51	0850	450	100	250	100	100	1	100	1	2
	0965	450	100	250	100	100	1	100	1	2
	1129	450	100	250	100	100	1	100	1	2

Table 83: Parameters depending on the Drive Model - Class 2T/4T / 3

SIZE	MODEL	DEF V/f Pattern	DEF PREBOOST [%Vmot]	BOOST @ 5% fmot and BOOST DEF [%Vmot]	Frequency for BOOST DEF [%fmot]	DEF Auto BOOST [%Vmot]
	M1	C013	C034	C035/C036	C037	C038
	M2	C056	C077	C078/C079	C080	C081
	M3	C099	C120	C121/C122	C123	C124
S05	0005	0:CONST	1.0	0	50	1
	0007	0:CONST	1.0	0	50	1
	0008	0:CONST	1.0	0	50	1
	0009	0:CONST	1.0	0	50	1
	0010	0:CONST	1.0	0	50	1
	0011	0:CONST	1.0	0	50	1
	0013	0:CONST	1.0	0	50	1
S05/S12	0014	0:CONST	1.0	0	50	1
	0015	0:CONST	1.0	0	50	1
S12	0016	0:CONST	1.0	0	50	1
	0020	0:CONST	1.0	0	50	1
	0017	0:CONST	1.0	0	50	1
	0023	0:CONST	1.0	0	50	1
	0025	0:CONST	1.0	0	50	1
	0030	0:CONST	1.0	0	50	1
	0033	0:CONST	1.0	0	50	1
S15	0034	0:CONST	1.0	0	50	1
	0036	0:CONST	1.0	0	50	1
S20	0037	0:CONST	1.0	0	50	1
	0040	0:CONST	1.0	0	50	1
S30	0049	0:CONST	1.0	0	50	1
	0060	0:CONST	1.0	0	50	1
	0067	0:CONST	1.0	0	50	1
	0074	0:CONST	1.0	0	50	1
S41	0086	0:CONST	1.0	0	50	1
	0113	0:CONST	0.5	0	50	1
	0129	0:CONST	0.5	0	50	1
	0150	0:CONST	0.5	0	50	1
S41	0162	0:CONST	0.5	0	50	1
	0180	2:FREE	0.2	-20	20	0
	0202	2:FREE	0.2	-20	20	0
	0217	2:FREE	0.2	-20	20	0
	0260	2:FREE	0.2	-20	20	0



SIZE	MODEL	DEF V/f Pattern	DEF PREBOOST [%Vmot]	BOOST @ 5% fmot and BOOST DEF [%Vmot]	Frequency for BOOST DEF [%fmot]	DEF Auto BOOST [%Vmot]
	M1	C013	C034	C035/C036	C037	C038
	M2	C056	C077	C078/C079	C080	C081
	M3	C099	C120	C121/C122	C123	C124
S51	0313	2:FREE	0.2	-20	20	0
	0367	2:FREE	0.2	-20	20	0
	0402	2:FREE	0.2	-20	20	0
S60	0457	2:FREE	0.2	-20	20	0
	0524	2:FREE	0.2	-20	20	0
S60P	0598P	2:FREE	0.2	-20	20	0
S65	0598	2:FREE	0.2	-20	20	0
	0748	2:FREE	0.2	-20	20	0
	0831	2:FREE	0.2	-20	20	0
S75	0964	2:FREE	0.2	-20	20	0
	1130	2:FREE	0.2	-20	20	0
	1296	2:FREE	0.2	-20	20	0
S90	1800	2:FREE	0.2	-20	20	0
	2076	2:FREE	0.2	-20	20	0
2xS41	0523	2:FREE	0.2	-20	20	0
2xS51	0599	2:FREE	0.2	-20	20	0
	0749	2:FREE	0.2	-20	20	0
	0800	2:FREE	0.2	-20	20	0
	0832	2:FREE	0.2	-20	20	0
3xS51	0850	2:FREE	0.2	-20	20	0
	0965	2:FREE	0.2	-20	20	0
	1129	2:FREE	0.2	-20	20	0

Table 84: Parameters depending on the Drive Model and Voltage Class - Class 2T/4T / 4

SIZE	MODEL	2T				4T			
		DEF Pmot [kW]	DEF Imot [A]	DEF Rstat [Ω]	DEF Ldisp [mH]	DEF Pmot [kW]	DEF Imot [A]	DEF Rstat [Ω]	DEF Ldisp [mH]
	M1	C017	C018	C022	C023	C017	C018	C022	C023
	M2	C060	C061	C065	C066	C060	C061	C065	C066
	M3	C103	C104	C108	C109	C103	C104	C108	C109
S05	0005	---	---	---	---	3	6.4	2.500	30.00
	0007	1.8	7.3	1.155	14.43	4	8.4	2.000	25.00
	0008	2.2	8.5	1.000	12.00	---	---	---	---
	0009	---	---	---	---	4.5	9	1.600	16.00
	0010	3	11.2	0.800	7.50	---	---	---	---
	0011	---	---	---	---	5.5	11.2	1.300	12.00
	0013	3.7	13.2	0.650	6.00	---	---	---	---
S05/S12	0014	---	---	---	---	7.5	14.8	1.000	8.00
	0015	4	16.6	0.600	5.00	---	---	---	---
S12	0016	4.5	15.7	0.462	3.46	9.2	17.9	0.800	6.00
	0020	5.5	19.5	0.346	2.89	11	21.0	0.600	5.00
	0017	---	---	---	---	9.2	21	0.800	6.00
	0023	7.5	25.7	0.300	2.50	---	---	---	---
	0025	---	---	---	---	15	29	0.400	3.00
	0030	---	---	---	---	18.5	35	0.300	2.50
	0033	11	36	0.200	1.50	---	---	---	---
S15	0034	---	---	---	---	22	41	0.250	2.00
	0036	---	---	---	---	25	46	0.250	2.00
	0037	15	50	0.100	1.15	---	---	---	---
	0040	15	50	0.115	1.15	25	46	0.200	2.00
S20	0049	18.5	61	0.087	1.15	30	55	0.150	2.00
	0060	22	71	0.069	1.15	37	67	0.120	2.00
	0067	25	80	0.058	0.69	45	80	0.100	1.20
	0074	30	96	0.046	0.69	50	87	0.080	1.20
S30	0086	32	103	0.035	0.58	55	98	0.060	1.00
	0113	45	135	0.023	0.58	75	133	0.040	1.00
	0129	50	150	0.023	0.58	80	144	0.040	1.00
	0150	55	170	0.017	0.58	90	159	0.030	1.00
S41	0162	65	195	0.012	0.58	110	191	0.020	1.00
	0180	75	231	0.010	0.52	132	228	0.018	0.9
	0202	80	250	0.010	0.52	160	273	0.018	0.9
	0217	110	332	0.009	0.46	185	321	0.015	0.8
	0260	110	332	0.007	0.35	220	375	0.012	0.6



SIZE	MODEL	2T				4T			
		Pmot DEF [kW]	Imot DEF [A]	Rstat DEF [Ω]	Ldisp DEF [mH]	Pmot DEF [kW]	Imot DEF [A]	Rstat DEF [Ω]	Ldisp DEF [mH]
	M1	C017	C018	C022	C023	C017	C018	C022	C023
	M2	C060	C061	C065	C066	C060	C061	C065	C066
	M3	C103	C104	C108	C109	C103	C104	C108	C109
S51	0313	132	390	0.006	0.28	250	375	0.012	0.50
	0367	150	458	0.005	0.23	280	480	0.010	0.40
	0402	160	475	0.005	0.17	355	589	0.010	0.30
S60	0457	200	593	0.005	0.14	315	528	0.008	0.25
	0524	220	661	0.004	0.12	355	589	0.007	0.20
S60P	0598P	250	732	0.003	0.12	400	680	0.006	0.20
S65	0598	250	732	0.003	0.12	400	680	0.006	0.20
	0748	280	840	0.002	0.09	500	841	0.003	0.15
	0831	330	985	0.001	0.06	560	939	0.002	0.10
S75	0964	400	1183	0.001	0.05	710	1200	0.002	0.09
	1130	450	1330	0.001	0.05	800	1334	0.001	0.09
	1296	560	1633	0.001	0.05	1000	1650	0.001	0.09
S90	1800	---	---	---	---	1200	2050	0.001	0.06
	2076	---	---	---	---	1400	2400	0.001	0.05
2xS41	0523	---	---	---	---	355	589	0.007	0.20
2xS51	0599	---	---	---	---	400	680	0.006	0.20
	0749	---	---	---	---	500	841	0.003	0.15
	0832	---	---	---	---	560	939	0.002	0.10
3xS51	0850	---	---	---	---	630	1080	0.002	0.09
	0965	---	---	---	---	710	1200	0.002	0.09
	1129	---	---	---	---	800	1334	0.001	0.09

34.3.2. VOLTAGE CLASS 5T/6T

Table 85: Parameters depending on the Drive Model - Class 5T/6T / 1

SIZE	MODEL	DRIVE INOM [A]	DRIVE IMAX [A]	DRIVE IPEAK [A]	DEF CARRIER [kHz]	MAX CARRIER [kHz]	DEF Silent Modulation
					C001 C002	C001 C002	C004
S12/S14	0003	7	8.5	10	3	5	YES
	0004	9	11	13	3	5	YES
	0006	11	13.5	16	3	5	YES
	0012	13	16	19	3	5	YES
	0018	17	21	25	3	5	YES
S14	0019	21	25	30	3	5	YES
	0021	25	30	36	3	5	YES
	0022	33	40	48	3	5	YES
	0024	40	48	58	3	5	YES
	0032	52	63	76	3	5	YES
S22	0042	60	72	86	3	5	YES
	0051	80	96	115	3	5	YES
	0062	85	110	132	3	5	YES
	0069	105	135	162	3	5	YES
S32	0076	125	165	198	2	4	YES
	0088	150	200	240	2	4	YES
	0131	190	250	300	2	4	YES
	0164	230	300	360	2	4	YES
	0172	265	345	414	2	4	YES
S42	0181	305	380	420	2	4	NO
	0201	330	420	420	2	4	NO
	0218	360	465	560	2	4	NO
	0259	400	560	560	2	4	NO
S52	0290	450	600	720	2	4	NO
	0314	500	665	798	2	4	NO
	0368	560	720	850	2	4	NO
	0401	640	850	850	2	4	NO
S65	0457	720	880	1056	2	4	NO
	0524	800	960	1152	2	4	NO
	0598	900	1100	1320	2	4	NO
	0748	1000	1300	1440	2	2	NO
S70	0831	1200	1440	1440	2	2	NO
S75	0964	1480	1780	2136	2	2	NO
	1130	1700	2040	2448	2	2	NO
S80	1296	2100	2520	2520	2	2	NO
S90	1800	2600	3100	3600	2	2	NO
	2076	3000	3600	3600	2	2	NO
2xS42	0459	720	880	880	2	4	NO
2xS52	0526	800	960	960	2	4	NO
	0600	900	1100	1100	2	4	NO
	0750	1000	1300	1300	2	4	NO
	0828	1200	1440	1440	2	4	NO
3xS52	0960	1480	1780	1780	2	4	NO
	1128	1700	2040	2040	2	4	NO

Table 86: Parameters depending on the Drive Model - Class 5T/6T / 2

SIZE	MODEL	DEF TFLUX [ms]	DEF ILIM DEC [%Inom]	DEF DCB RAMP [ms]	DEF Acc. Time [sec]	DEF Dec. Time [sec]	S – Acc/Dec DEF	Fire Mode Ramps DEF [sec]	Unit Of Meas. Acc. / Dec. DEF [sec]	Dec. Ramp Ext. DEF
	M1	C041	C045	C222	P009	P010	P022	P032 P033	P014 P020	C210
	M2	C084	C088	C223	P012	P013	P023			
	M3	C127	C131	C224	P015	P016	P024			
S12/S14	0003	300	150	50	10	10	50	10	0.1	0.2
	0004	300	150	50	10	10	50	10	0.1	0.2
	0006	300	150	50	10	10	50	10	0.1	0.2
	0012	300	150	50	10	10	50	10	0.1	0.2
	0018	300	150	50	10	10	50	10	0.1	0.2
S14	0019	300	150	50	10	10	50	10	0.1	0.2
	0021	300	150	50	10	10	50	10	0.1	0.2
	0022	300	150	50	10	10	50	10	0.1	0.2
	0024	300	150	50	10	10	50	10	0.1	0.2
	0032	300	150	50	10	10	50	10	0.1	0.2
S22	0042	300	150	80	10	10	50	10	0.1	0.2
	0051	300	150	80	10	10	50	10	0.1	0.2
	0062	300	150	80	10	10	50	10	0.1	0.2
	0069	300	150	100	10	10	50	10	0.1	0.2
S32	0076	300	150	100	10	10	50	10	0.1	0.2
	0088	300	150	150	10	10	50	10	0.1	0.2
	0131	300	150	150	10	10	50	10	0.1	0.2
	0164	300	150	200	10	10	50	10	0.1	0.2
	0172	300	150	200	10	10	50	10	0.1	0.2
S42	0181	450	100	200	100	100	1	100	1	2
	0201	450	100	220	100	100	1	100	1	2
	0218	450	100	250	100	100	1	100	1	2
	0259	450	100	250	100	100	1	100	1	2
S52	0290	450	100	250	100	100	1	100	1	2
	0314	450	100	250	100	100	1	100	1	2
	0368	450	100	250	100	100	1	100	1	2
	0401	450	100	250	100	100	1	100	1	2
S65	0457	450	100	250	100	100	1	100	1	2
	0524	450	100	250	100	100	1	100	1	2
	0598	450	100	250	100	100	1	100	1	2
	0748	450	100	250	100	100	1	100	1	2
S70	0831	450	100	250	100	100	1	100	1	2
S75	0964	450	100	250	100	100	1	100	1	2
	1130	450	100	250	100	100	1	100	1	2
S80	1296	450	100	250	100	100	1	100	1	2
S90	1800	450	100	250	100	100	1	100	1	2
	2076	450	100	250	100	100	1	100	1	2
2xS42	0459	450	100	250	100	100	1	100	1	2
2xS52	0526	450	100	250	100	100	1	100	1	2
	0600	450	100	250	100	100	1	100	1	2
	0750	450	100	250	100	100	1	100	1	2
	0828	450	100	250	100	100	1	100	1	2
3xS52	0960	450	100	250	100	100	1	100	1	2
	1128	450	100	250	100	100	1	100	1	2

**SINUS PENTA
PENTA MARINE**



PROGRAMMING GUIDE



Table 87: Parameters depending on the Drive Model - Class 5T/6T / 3

SIZE	MODEL	DEF V/f Pattern	DEF PREBOOST [%Vmot]	BOOST @ 5% fmot and BOOST DEF [%Vmot]	Frequency for BOOST DEF [%fmot]	DEF Auto BOOST [%Vmot]
	M1	C013	C034	C035/C036	C037	C038
	M2	C056	C077	C078/C079	C080	C081
	M3	C099	C120	C121/C122	C123	C124
S12/S14	0003	0:CONST	1.0	0	50	1
	0004	0:CONST	1.0	0	50	1
	0006	0:CONST	1.0	0	50	1
	0012	0:CONST	1.0	0	50	1
	0018	0:CONST	1.0	0	50	1
S14	0019	0:CONST	1.0	0	50	1
	0021	0:CONST	1.0	0	50	1
	0022	0:CONST	1.0	0	50	1
	0024	0:CONST	1.0	0	50	1
	0032	0:CONST	1.0	0	50	1
S22	0042	0:CONST	1.0	0	50	1
	0051	0:CONST	1.0	0	50	1
	0062	0:CONST	1.0	0	50	1
	0069	0:CONST	1.0	0	50	1
S32	0076	0:CONST	1.0	0	50	1
	0088	0:CONST	1.0	0	50	1
	0131	0:CONST	0.5	0	50	1
	0164	0:CONST	0.5	0	50	1
S42	0181	2:FREE	0.2	-20	20	0
	0201	2:FREE	0.2	-20	20	0
	0218	2:FREE	0.2	-20	20	0
	0259	2:FREE	0.2	-20	20	0
S52	0290	2:FREE	0.2	-20	20	0
	0314	2:FREE	0.2	-20	20	0
	0368	2:FREE	0.2	-20	20	0
	0401	2:FREE	0.2	-20	20	0
S65	0457	2:FREE	0.2	-20	20	0
	0524	2:FREE	0.2	-20	20	0
	0598	2:FREE	0.2	-20	20	0
	0748	2:FREE	0.2	-20	20	0
S70	0831	2:FREE	0.2	-20	20	0
S75	0964	2:FREE	0.2	-20	20	0
	1130	2:FREE	0.2	-20	20	0
S80	1296	2:FREE	0.2	-20	20	0
S90	1800	2:FREE	0.2	-20	20	0
	2076	2:FREE	0.2	-20	20	0
2xS42	0459	2:FREE	0.2	-20	20	0
2xS52	0526	2:FREE	0.2	-20	20	0
	0600	2:FREE	0.2	-20	20	0
	0750	2:FREE	0.2	-20	20	0
	0828	2:FREE	0.2	-20	20	0
3xS52	0960	2:FREE	0.2	-20	20	0
	1128	2:FREE	0.2	-20	20	0

Table 88: Parameters depending on the Drive Model an Voltage Class - Class 5T/6T / 4

SIZE	MODEL	5T				6T			
		DEF Pmot [kW]	DEF Imot [A]	DEF Rstat [Ω]	DEF Ldisp [mH]	DEF Pmot [kW]	DEF Imot [A]	DEF Rstat [Ω]	DEF Ldisp [mH]
	M1	C017	C018	C022	C023	C017	C018	C022	C023
	M2	C060	C061	C065	C066	C060	C061	C065	C066
	M3	C103	C104	C108	C109	C103	C104	C108	C109
S12/S14	0003	3.0	4.4	3.608	43.30	4.0	4.8	4.330	51.96
	0004	4.0	5.7	3.608	43.30	4.0	4.8	4.330	51.96
	0006	5.5	7.6	2.887	36.08	7.5	8.4	3.464	43.30
	0012	7.5	10.0	1.732	15.88	7.5	8.4	2.078	19.05
	0018	9.2	12.5	1.155	8.66	11.0	12.1	1.386	10.39
S14	0019	11.0	14.0	1.155	8.66	11.0	12.1	1.386	10.39
	0021	15.0	20.0	0.866	7.22	15.0	16.8	1.039	8.66
	0022	18.5	25.0	0.866	7.22	22.0	23.0	1.039	8.66
	0024	22.0	28.0	0.577	4.33	22.0	23.0	0.693	5.20
	0032	30.0	39.0	0.433	3.61	37.0	39.0	0.520	4.33
S22	0042	37	47	0.217	2.89	37	39	0.260	3.46
	0051	45	55	0.173	2.89	55	56	0.208	3.46
	0062	55	70	0.173	2.89	55	55.8	0.208	3.46
	0069	55	70	0.144	1.73	75	78.1	0.173	2.08
S32	0076	75	95	0.115	1.73	90	94.4	0.139	2.08
	0088	110	135	0.087	1.44	110	112.6	0.104	1.73
	0131	110	135	0.058	1.44	160	158	0.069	1.73
	0164	132	168	0.029	1.44	185	185	0.035	1.73
S42	0181	185	225	0.026	1.44	220	220	0.031	1.73
	0201	200	240	0.026	1.30	250	250	0.031	1.56
	0218	220	275	0.022	1.15	315	310	0.026	1.39
	0259	280	336	0.017	0.87	355	341	0.021	1.04
S52	0290	300	358	0.017	0.72	400	390	0.020	0.86
	0314	330	395	0.017	0.72	450	440	0.020	0.86
	0368	355	420	0.014	0.57	500	480	0.017	0.69
	0401	400	473	0.014	0.43	560	544	0.017	0.51
S65	0457	500	585	0.012	0.36	560	544	0.014	0.43
	0524	560	630	0.010	0.29	630	626	0.012	0.35
	0598	630	720	0.009	0.29	710	696	0.010	0.35
	0748	710	800	0.004	0.22	900	858	0.005	0.26
S70	0831	800	900	0.003	0.14	1000	954	0.003	0.17
S75	0964	1000	1450	0.003	0.13	1220	1187	0.003	0.16
	1130	1170	1360	0.001	0.13	1400	1360	0.001	0.16
S80	1296	1340	1560	0.001	0.13	1610	1560	0.001	0.16
S90	1800	1750	2050	0.001	0.08	2100	2100	0.001	0.10
	2076	2000	2400	0.001	0.07	2400	2400	0.001	0.08
2xS42	0459	500	626	0.012	0.36	630	626	0.014	0.43
2xS52	0526	500	696	0.010	0.29	710	696	0.012	0.35
	0600	630	773	0.009	0.29	800	773	0.010	0.35
	0750	710	800	0.004	0.22	900	858	0.005	0.26
	0828	710	800	0.003	0.14	1000	954	0.003	0.17
3xS52	0960	1000	1145	0.003	0.13	1200	1187	0.003	0.16
	1128	1000	1360	0.001	0.13	1400	1360	0.002	0.16

35. LIMITS MENU

35.1. Overview

The **Limits Menu** defines the current/torque limits applied to the control functions (IFD, VTC or FOC controls) selected for the three connected motors.

For IFD control, current limits are used. Three limit current levels are available, which are expressed as a percentage of the motor rated current:

- 1) Current limit while accelerating;
- 2) Current limit at constant rpm;
- 3) Current limit while decelerating.

Two special parameters are also available; one sets the decrease of the limit current value when the motor runs at constant power (field weakening), while the other parameter disables the frequency decrease in case of acceleration current limit (this is useful for inertial loads).

If a VTC control or a FOC control is used, limits are expressed as a percentage of the rated motor torque.

Values set in the two parameters relating to min. torque and max. torque represent the limits for saturation of the control torque demand. If an external torque limit is set (**C147** in the CONTROL METHOD MENU), the values set in the parameters above represent the range of the source used for limitation; the torque ramp times set in the RAMPS MENU will be applied to the preset limit torque reference.

When in field weakening mode, such as when the system operates at a higher speed than the rated motor speed set in **C016**, the torque limits defined by parameters **C047/C048** are decreased following a law $1/\text{speed}$ at speed exceeding the rated speed, to limit the maximum mechanical power required to the motor. The external torque limit programmed via **C147** is not re-scaled to $1/\text{speed}$, but is saturated between the two limits defined above, as shown in Figure 46.

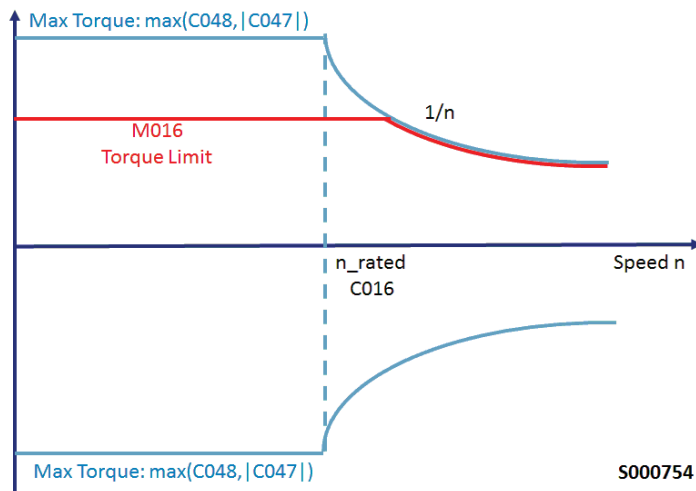

Figure 46: Torque limit for VTC and FOC controls in field weakening mode

The Ipeak current load is available (see Table 81 and Table 85) for a maximum time of 3 seconds and only if the preset carrier frequency is lower than/equal to the default frequency value (see Table 81 and Table 85). When operating with synchronous modulation, the current peak value dynamically decreases when the output frequency increases.

Manually enabling/disabling that function can be done only when using the IFD control with current limit parameters **C043/C044/C045**. When using the **VTC** or **FOC** control, the system will automatically handle the maximum current value that can be used also based on the torque limit configured with **C047/C048**.

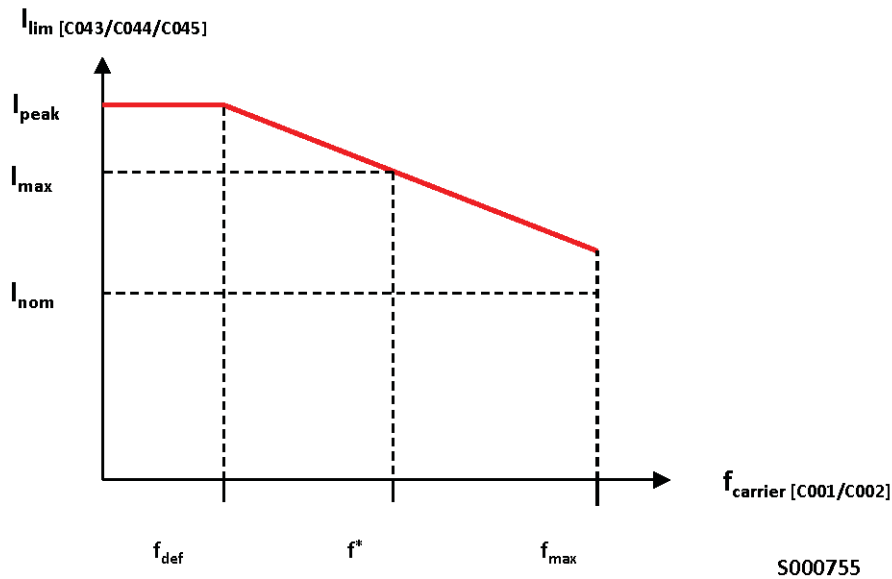

Figure 47: Current limit reduction based on carrier frequency: models with I_{peak}

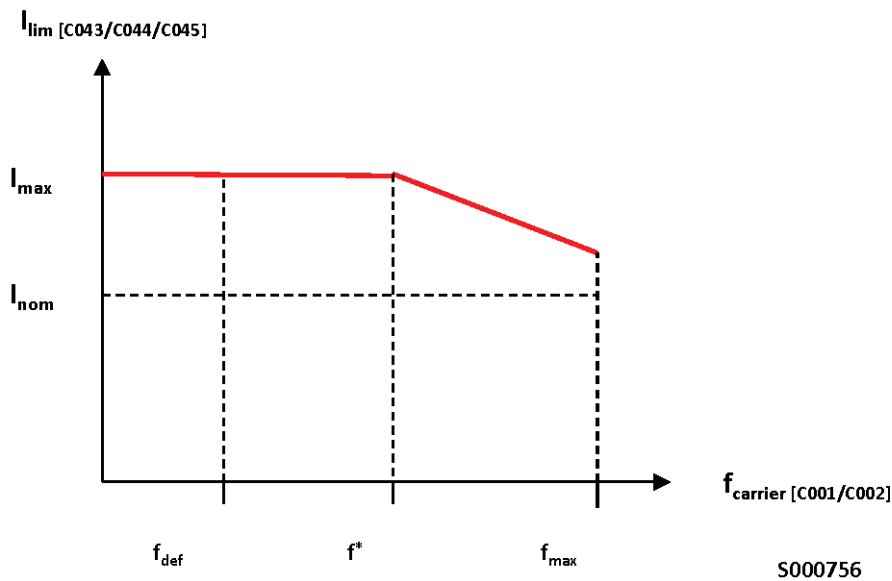

Figure 48: Current limit reduction based on carrier frequency: models without I_{peak}

f_{def}: default carrier frequency
 f*: maximum carrier frequency to obtain I_{max}
 f_{max}: maximum programmable carrier frequency



CAUTION

The pictures above show the I_{max}/I_{peak} current limit based on carrier frequency. Please refer to the Sinus Penta's Installation Guide for the maximum carrier values recommended based on I_{nom} rated current.

35.2. List of Parameters C043 to C135

Table 89: List of Parameters C043 to C135

Parameter		FUNCTION	User Level	MODBUS Address	DEFAULT VALUES
C043	M1	Current limit while accelerating	BASIC	1043	150%
C086	M2		ADVANCED	1086	
C129	M3			1129	
C044	M1	Current limit at constant rpm	BASIC	1044	150%
C087	M2		ADVANCED	1087	
C130	M3			1130	
C045	M1	Current limit while decelerating	BASIC	1045	See Table 82 and Table 86
C088	M2		ADVANCED	1088	
C131	M3			1131	
C046	M1	Current limit decrease in field weakening	ADVANCED	1046	0: Disabled
C089	M2			1089	
C132	M3			1132	
C047	M1	Minimum torque	ADVANCED	1047	0.0%
C090	M2			1090	
C133	M3			1133	
C048	M1	Maximum torque	BASIC	1048	120.0%
C091	M2		ADVANCED	1091	
C134	M3			1134	
C050	M1	Frequency decrease during acceleration limit	ADVANCED	1050	0: Enabled
C093	M2			1093	
C136	M3			1136	

C043 (C086, C129) Current Limit While accelerating

C043 (Motor 1) C086 (Motor 2) C129 (Motor 3)	Range	0 ÷ 400 (*)	0: Disabled 1.0% ÷ minimum between Ipeak/Imot and 400%
	Default	150	150%
	Level	BASIC (C043); ADVANCED (C086, C129)	
	Address	1043, 1086, 1129	
	Control	IFD	
	Function	This parameter defines the current limit while accelerating; it is expressed as a percentage of the rated current of the selected motor. No limit is applied if this parameter is set to 0: Disabled.	

(*) The maximum allowable value depends on the drive model.

C044 (C087, C130) Current Limit at Constant Rpm

C044 (Motor 1) C087 (Motor 2) C130 (Motor 3)	Range	0 ÷ 400 (*)	0: Disabled 1.0% ÷ minimum between Ipeak/Imot and 400%
	Default	150	150%
	Level	BASIC (C044); ADVANCED (C087, C130)	
	Address	1044, 1087, 1130	
	Control	IFD	
	Function	This parameter defines the current limit at constant rpm; it is expressed as a percentage of the rated current of the selected motor. No limit is applied if this parameter is set to 0: Disabled.	

(*) The maximum allowable value depends on the drive model.

C045 (C088, C131) Current Limit while Decelerating

C045 (Motor 1) C088 (Motor 2) C131 (Motor 3)	Range	0 ÷ 400 (*)	0: Disabled 1.0% ÷ minimum between Ipeak/Imot and 400%
	Default	See Table 82 and Table 86	
	Level	BASIC (C045); ADVANCED (C088, C131)	
	Address	1045, 1088, 1131	
	Control	IFD	
	Function	This parameter defines the current limit while decelerating; it is expressed as a percentage of the rated current of the selected motor. No limit is applied if this parameter is set to 0: Disabled.	

(*) The maximum allowable value depends on the drive model.

C046 (C089, C132) Current Limit Decrease in Field weakening

C046 (Motor 1) C089 (Motor 2) C132 (Motor 3)	Range	0 ÷ 1	0: Disabled 1: Enabled
	Default	0	0: Disabled
	Level	ADVANCED	
	Address	1046, 1089, 1132	
	Control	IFD	



	Function	<p>This parameter enables the current limit decrease function in field weakening. The current limit is multiplied by the ratio between the motor rated torque and the frequency forced to the drive:</p> <p>limit = current limit being used * (Fmot/ Fout).</p>
--	-----------------	--

C047 (C090, C133) Minimum Torque

C047 (Motor 1) C090 (Motor 2) C133 (Motor 3)	Range	-5000 ÷ 5000 (*)	-500.0% ÷ +500.0%
	Default	0	0.0%
	Level	ADVANCED	
	Address	1047, 1090, 1133	
	Control	VTC and FOC	
	Function	This parameter sets the min. limit of the torque demanded by the control being used. Torque is expressed as a percentage of the rated torque of the selected motor.	



NOTE

If an external torque limit is set (**C147** in the CONTROL METHOD MENU), the values set in the parameters above represent the range of the source used for limitation; they can be reduced by adjusting the external source; the torque ramp times set in the RAMPS MENU will be applied to the preset limit torque reference (**P026–P027**).

C048 (C091, C134) Maximum Torque

C048 (Motor 1) C091 (Motor 2) C134 (Motor 3)	Range	-5000(*) ÷ 5000 (*)	-500.0% ÷ +500.0%
	Default	1200	120.0%
	Level	BASIC (C048); ADVANCED (C091;C134)	
	Address	1048, 1091, 1134	
	Control	VTC and FOC	
	Function	This parameter sets the max. limit of the torque demanded by the control being used. Torque is expressed as a percentage of the rated torque of the selected motor.	



NOTE

If an external torque limit is set (**C147** in the CONTROL METHOD MENU), the values set in the parameters above represent the range of the source used for limitation; the torque ramp times set in the RAMPS MENU will be applied to the preset limit torque reference (**P026–P027**).

C050 (C093, C136) Frequency Decrease during Acceleration Limit

C050 (Motor 1) C093 (Motor 2) C136 (Motor 3)	Range	0 ÷ 1	0: Enabled 1: Disabled
	Default	0	0: Enabled
	Level	ADVANCED	
	Address	1050, 1093, 1136	
	Control	IFD	
	Function	This parameter enables output frequency decrease during acceleration limit.	



NOTE

Setting “1:Disabled” is recommended for high inertia loads. When high inertia loads are connected to the drive, the frequency decrease can lead to strong regeneration and DC-bus voltage oscillations.

36. CONTROL METHOD MENU

36.1. Overview

NOTE

Please refer to the Sinus Penta's Installation Guide for the hardware description of digital inputs (COMMANDS) and analog inputs (REFERENCES).
See also the INPUTS FOR REFERENCES MENU and the DIGITAL INPUTS MENU.

The drive is factory set to receive digital commands via the terminal board; the main speed reference is sent from the REF analog input, and no external limit for torque limitation is enabled.

The parameters in this menu allow selecting the following:

- The source of the **drive commands** (digital inputs) from **three signal sources** (through parameters **C140, C141, C142**) which are logically matched so as to obtain an active **M031** command set. For each of these 3 **parameters** you can select the source of the command signals from **4 different sources**;
- The source of the **speed reference** (or torque reference) from **4 different sources** (that can be selected with parameters **C143, C144, C145, C146**) that **can be summed up together**.
For each of these **4 parameters**, you can select the source of the reference signals from **9 different sources**;
- The source of the **torque / speed limit** reference (through parameter **C147**, allowing selecting the reference source from **9 different sources**).

Therefore, you can select and enable different **command sources** (hardware or virtual sources), different speed (or torque) **references** (hardware or virtual sources) and enable an external torque **limit**.

The drive **commands** may be sent from:

- The hardware terminal board (terminal board on the control board), which is logically separated into terminal board A and terminal board B;
- The keypad;
- The virtual remote terminal board: through serial link with MODBUS communications protocol;
- The virtual remote terminal board: through Fieldbus (optional board).

Multiple terminal boards may also be enabled (up to 3 terminal boards with parameters **C140, C141, C142**); in this case, the drive will apply logic functions **OR** or **AND** to the different terminals to obtain the activated terminal board (see Command Sources).

The following **references** and torque limit signals may be sent:

- Three analog inputs acquired to the hardware terminal board (REF, AIN1, AIN2), plus two analog inputs (XAIN4, XAIN5) acquired to the hardware terminal board located on ES847 optional board;
- FIN frequency input;
- Encoder input;
- Keypad;
- Serial link with MODBUS communications protocol;
- Fieldbus (optional board);
- Up/Down from MDI (Up and Down digital inputs).

Multiple reference sources may be enabled at the same time (up to 4 reference sources with parameters **C143, C144, C145, C146**); in this case, the drive will consider the sum of all active reference as the main reference.

Finally, a dynamic selection between two command sources and two reference sources is allowed when using the digital input configured as Source Selection (see **C179**); otherwise, the inputs configured as Command Selection and Reference Selection (**C179a** and **C179b**) can be used.

36.1.1. COMMAND SOURCES

The drive commands may be sent from the following sources:

- 0: Disabled
- 1: Terminal board A
- 2: Serial link (with MODBUS protocol)
- 3: Fieldbus (fieldbus on optional board)
- 4: Terminal board B
- 5: Keypad (remotable display/keypad)

The factory-setting enables only Terminal Board A (C140=1 and C141=1) as a command source (see also the DIGITAL INPUTS MENU). Both Terminal board A and B refer to the same terminal board located on the control board, but allow switching between one set of START, STOP, REVERSE commands sent to three terminals to a different set of commands sent to three different terminals.

Most commands may be delayed (when enabled or disabled): refer to the TIMERS MENU.

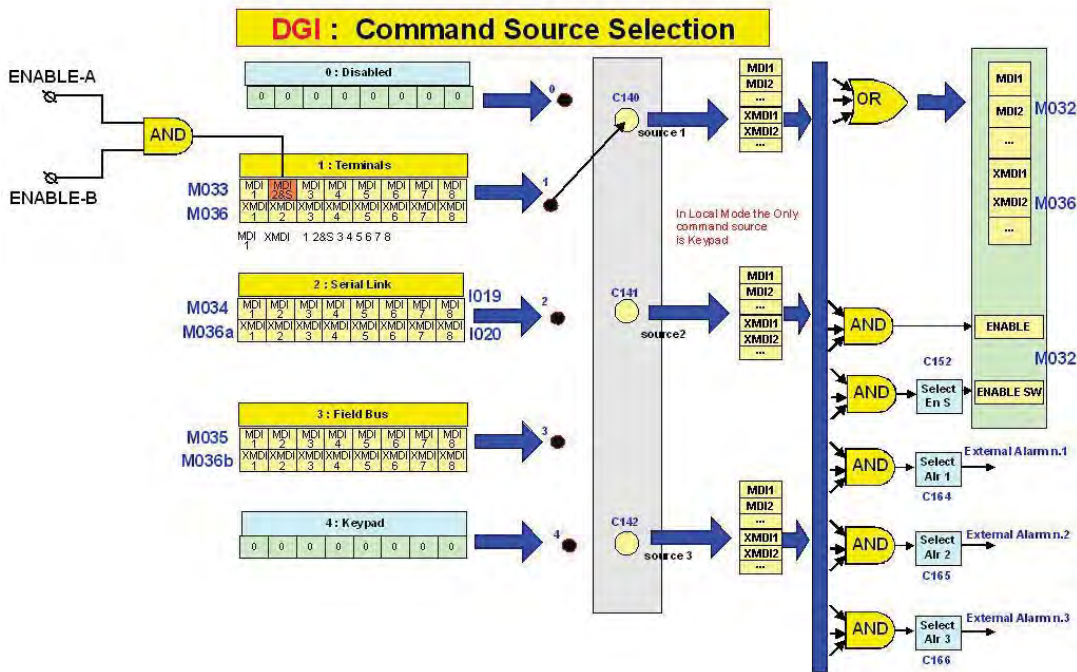

Figure 49: Selecting the command sources

If the keypad is not selected as a command source or, when the keypad is selected, if the the STOP input function is also enabled (C150≠0), more than one command source may be enabled at a time by programming parameters C140, C141, C142 accordingly. The logic function for the different command sources is as follows:

Source programmed in:	Enable Conditions:	
	If: C179 (Source Selection) = 0: Disable and (logic AND) C179a (Command Selection) = 0: Disable	If: C179 = MDIx input or (logic OR) C179a = MDIx input
C140	Always active	Active if MDIx = 0
C141	Always active	Active if MDIx = 1
C142	Always active	Always active



Table 90: Enable conditions of the command sources

- **AND** for the terminals allocated to the **ENABLE** functions (**MDI2&S inputs** on physical terminals, **MDI2** via serial command or fieldbus), **ENABLE-SW**, **External Alarms n.1, n.2, n.3**.
- **OR** for all other terminals.



NOTE

If the keypad is enabled as a command source, the **START, STOP, RESET, LOC/REM, FWD/REV** functions are enabled (to disable **LOC/REM** and **FWD/REV** see parameter **P269**). The keypad is ignored for the processing of logic functions (AND/OR) of the other command sources that are enabled at that moment.



NOTE

As the **ENABLE-A** and **ENABLE-B** commands of the **physical terminal board** are a hardware safety device (they enable the drive) they are **always active**, even when none of parameters **C140, C141** or **C142** selects the terminal board (=1).

If the **STO** function is to be adopted, the control mode and the control circuit of these signals must be accomplished as per the **Safe Torque Off Function - Application Manual**. That manual also includes a detailed validation procedure of the control configuration of the **STO** function to be executed upon first start-up and also periodically at yearly intervals.



NOTE

The commands for the **External Alarm n.1, n.2, n.3** functions are always considered for the drive terminal board only.



NOTE

The **LOCAL mode**, that can be enabled with the **LOC/REM** key from the keypad or with the **LOCAL** command function from the terminal board (see **C180**), forces the keypad as the only command source, thus ignoring the values set in parameters **C140, C141, C142**.

The following functions are therefore enabled for the hardware terminal board: **External Alarm n.,1 n.2, n.3 (C164, C165, C166), Motor Sel. n.2 (C173), Motor Sel. n.3 (C174), SLAVE (C170), Source Selection (C179, C179a, C179b), LOCAL (C180)** and the **ENABLE-A** and **ENABLE-B** and **RESET** functions are always enabled for terminals **MDI2, S** and **MDI3**.

The **ENABLE-SW** and **DISABLE** functions are enabled in **LOCAL mode** if at least one of parameters **C140, C141, C142** is set to 1 (terminal board).



NOTE

If **C179** (Source Selection) and **C179a** (Command Selection) are disabled, it is not possible to enable the Source Keypad together with a different source for **C140** e **C141**. This is to avoid conflicts in managing the Start and Stop inputs on the terminals (or other sources) or on the keypad.

However, there is one exception: if the Stop function is enabled programming **C150**, the conflict can be solved because terminal inputs can be managed through the keypad.



NOTE

If **C140** or **C141** are enabled through the terminals, it is not possible to enable the Source Keypad for **C142**, irrespective of the settings for **C179/C179a**. This is because **C142** is always considered OR and, again, it may cause conflicts in the management through terminals or keypad.

Also in this case, it is possible to enable **C142** through the keypad by programming **C150**.

Table 91: Remote command inputs from serial link

MODBUS Address	Input Code	User Level	Description	Range
1406	I019	BASIC	Remote, virtual terminal board from serial link	Bit input: 0÷1 for 8 bits corresponding to MDI1÷ MDI8
1407	I020	BASIC	Auxiliary, virtual terminal board from serial link	Bit input: 0÷1 for 8 bits corresponding to XMDI1÷ XMDI8

Example:

If **C140 = 3** (Fieldbus) and **C141 = 2** (Serial link), the **ENABLE** command is sent by closing terminals **ENABLE-A** and **ENABLE-B** on the terminal board and (AND) by forcing bit **MDI2** from the serial link on input **I019** (MODBUS address: 1406) and bit **MDI2** from Fieldbus (see the **FIELD BUS CONFIGURATION MENU**).

The **START** command may also be sent (OR) by forcing bit **MDI1** from serial link on input **I019** or by forcing bit **MDI1** from Fieldbus for the relevant variable.

36.1.2. SPEED/TORQUE REFERENCE SOURCES

The “**main reference**” is the value at constant speed to be attained by the controlled variable (speed or torque) (**M000**, **M007**) “required” from the drive.

This reference is acquired by the drive only if the **START** command and the **ENABLE-A** and **ENABLE-B** commands are active; otherwise, it is ignored.

When the main reference is acquired by the drive (**START**, **ENABLE-A** and **ENABLE-B** are active), it becomes the input signal controlled by the “time ramp” functions that generate the speed/torque reference setpoint for the connected motor.

The speed or torque references may come from the following command sources:

- **Source disabled;**
- **REF** (single-ended analog input from terminal board);
- **AIN1** (differential analog input from terminal board);
- **AIN2** (differential analog input from terminal board);
- **FIN** (frequency input from terminal board; see also the *ENCODER/FREQUENCY INPUTS MENU*);
- **Serial link** (with *MODBUS* protocol);
- **Fieldbus** (fieldbus in optional board);
- **Keypad** (removable display/keypad);
- **Encoder** (in terminal board *MDI6–ECHA*, *MDI7–ECHB* or optional board);
- **Up Down from MDI** (Up/down from digital inputs, see **C161** and **C162**)
- **XAIN4** (auxiliary, differential voltage analog input from *ES847* terminal board)
- **XAIN5** (auxiliary, differential current analog input from *ES847* terminal board)

The activation logic function for the different reference sources is as follows:

Source programmed in:	Enable conditions:	
	If: C179 (Source Selection) = 0: Disable and (logic AND) C179b (Reference Selection) = 0: Disable	If: C179 = MDIx input or (logic OR) C179b = MDIx input
C143	Always active	Active if MDIx = 0
C144	Always active	Active if MDIx = 1
C145	Always active	Always active
C146	Always active	Always active

Table 92: Enable conditions of the reference sources

As per factory-setting, only one source is enabled (**C143**=1, **C144**=2, **C145**=0 and **C146**=0). Because the digital input for source selection is programmed (**C179**=6: **MDI6**, see Digital Inputs Menu), if this input is inactive, only the REF item is selected (please refer to the *INPUTS FOR REFERENCES MENU*).

If multiple reference sources are enabled, by programming also **C144**, **C145**, or **C146**, the actual calculated reference is **the algebraic sum of all the active references** (see *How to Manage the Reference Sources*).

REF, AIN1 and AIN2

The sources called REF, AIN1 and AIN2 come from the analog inputs in the terminal board and generate a reference resulting from the setting of the relevant parameters (from **P050** to **P064**). See the *INPUTS FOR REFERENCES MENU* for the scaling, offset compensation and filtering of the reference obtained. The inputs may be used as voltage or current inputs depending on the setting and the position of the relevant dip-switches (see the Sinus Penta’s Installation Guide).

FIN

The **FIN** source is a frequency input on terminal **MDI6 (FINA)** or **MD18 (FINB)** and it generates a reference determined by the setting of the relevant parameters (from **P071** to **P072**), allowing proper scaling (see the *INPUTS FOR REFERENCES MENU* and the *ENCODER/FREQUENCY INPUTS MENU*).

SERIAL LINK

The **Serial Link** source is an input located on the MODBUS link: the reference value must be written by the user to the addresses below:

Table 93: Reference inputs from serial link

MODBUS Address	Input Code	User Level	Reference	Description	Range	Unit of measure
1412	I025	BASIC	Speed	Speed reference/limit (integer portion)	Min. speed ÷ Max. speed	RPM
1413	I026	BASIC	Speed	Speed reference/limit (decimal portion)	-99 ÷ 99	RPM/100
1416	I029	BASIC	Torque	Torque reference/limit	Min. torque ÷ Max. torque	Tenths %

I025 is

- the speed reference if at least one among parameters C143..146 is set to 5:Serial Link and the type of reference of the active motor (parameters C011 / C054 / C097) is set to 0:Speed;
- the speed limit if C147=5:Serial Link and the type of reference of the active motor is set to 2:Torque with Speed Limit.



NOTE

The range of this reference depends on the active Minimum Speed value and Maximum Speed value as set in parameters C028 and C029 (for motor 1, and relevant parameters for motor 2 and motor 3).

If $C029 \leq C028$, then **Min. speed = C029, Max. speed = C028.**

If $C029 \geq C028$, then **Min. speed = C028, Max. speed = C029.**



NOTE

I026 is the decimal portion of the speed reference in RPM and has effect in FOC motor control mode only.

I029 is

- the torque reference if at least one among parameters C143..146 is set to 5:Serial Link and the type of reference of the active motor (parameters C011 / C054 / C097) is set to 1:Torque or 2:Torque with Speed Limit;
- The torque limit if C147=5:Serial Link.



NOTE

I029 is expressed as a percentage of the rated motor torque.

Reference range:

If $C047 \leq C048$, then **Min. torque = C047, Max. torque = C048.**

If $C047 \geq C048$, then **Min. torque = C048, Max. torque = C047.**

In case of torque limit, its minimum value is internally set =0 if the minimum torque limit is <0.

FIELD BUS

For a description of the **Fieldbus** source, see the FIELD BUS CONFIGURATION MENU.

KEYPAD

The keypad is a special reference source. The keypad reference may be changed with the ▲ and ▼ keys only if this reference is on a Keypad page displaying a reference in line 4.

If the keypad is enabled, a **variation** to the active reference may be added through an algebraic sum (calculated by processing the other reference sources that are activated at that moment).



NOTE

The reference variation method can be selected with parameters P067, P068, P069, and C163.

This function is the same as the **UP** and **DOWN** functions from the terminal board (see the DIGITAL INPUTS MENU: C161 and C162 and P068+P069 in the INPUTS FOR REFERENCES MENU).



NOTE

The **LOCAL mode**, that can be enabled with the **LOC/REM** key on the keypad or with the **LOCAL** command function from terminal board (see C180), forces the keypad to become the only command and reference source, thus ignoring the values set in parameters C143, C144, C145, C146.

ENCODER

The **Encoder** source is an encoder input: it can come from the terminal board (terminals **MDI6**, **MDI7**) in Encoder A, or from the optional Encoder B board (see the ENCODER/FREQUENCY INPUTS MENU). It generates a reference resulting from the correct setting of the relevant parameters (**P073**, **P074**), allowing the relevant scaling (see the INPUTS FOR REFERENCES MENU).

UP/DOWN from digital inputs

To enable the **UP/DOWN from digital inputs** also set the relevant Up and Down inputs (see the DIGITAL INPUTS MENU).

XAIN4 and XAIN5

XAIN4 and XAIN5 come from the analog inputs in the terminal board of ES847 and generate a reference determined by the settings of the relevant parameters (**P390** to **P399**), allowing proper scaling, offset compensation and filtering (see the INPUTS FOR REFERENCES FROM OPTIONAL BOARD).

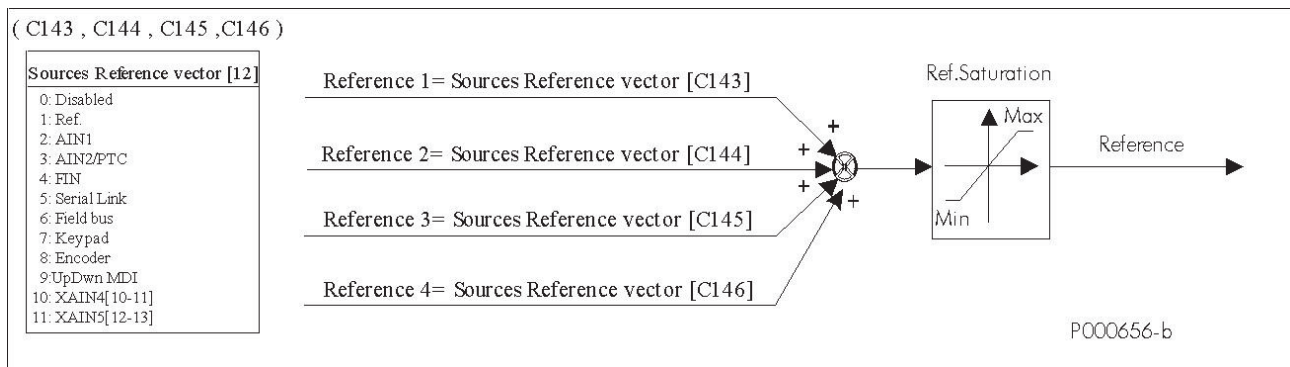

Figure 50: Selecting the source references

36.1.3. ALTERNATIVE COMMAND AND REFERENCE SOURCES

A digital input can be set as a selector between 2 alternative command and reference sources.

Example:

- C179** MDI To select sources = **MDI6**
- C140** To select command source number 1 = **Keypad**
- C141** To select command source number 2 = **Fieldbus**
- C143** To select reference source number 1 = **AIN1**
- C144** To select reference source number 2 = **Fieldbus**

If **MD16** (in the drive terminal board) set as a selector is open, the drive will consider number 1 as reference and command sources (that is **C140 = Keypad** and **C143 = AIN1**); if it is closed, number 2 will be considered (**C141 = Fieldbus** and **C144 = Fieldbus**). See also How to Manage the Reference Sources.

If references sources 3 and 4 (**C145 and C146**) are not set to Disable, the reference sent for these sources shall be a sum of the source selected by MD16 vector.

Please refer to **C179** in the DIGITAL INPUTS MENU.

36.1.4. TORQUE LIMIT SOURCE

The source of the Torque Limit can be selected with parameter **C147**.

The Torque limit function is a limit of the absolute value of the torque required from the drive.
(– Torque limit) <= torque <= (+ Torque limit)

The torque limit references may be selected from the following:

0. Source disabled

1. **REF** (single-ended analog input from terminal board);
2. **AIN1** (differential analog input from terminal board);
3. **AIN2** (differential analog input from terminal board; see also the ENCODER/FREQUENCY INPUTS MENU);
4. **FIN** (frequency input from terminal board);
5. **Serial link** (with MODBUS protocol);
6. **Fieldbus** (fieldbus on optional board);
7. **Keypad** (remotable display/keypad);
8. **Encoder** (in terminal board MDI6–ECHA , MDI7–ECHB or optional board);
9. **Up Down from MDI** (Up/down from digital inputs, see **C161 and C162**)
10. **XAIN4** (auxiliary, differential voltage analog input from ES847 terminal board)
11. **XAIN5** (auxiliary, differential current analog input from ES847 terminal board)



NOTE

If the reference source is disabled, the torque limit results from the max. absolute torque determined by the drive size and the motor size.

The max. absolute torque is the max. value ranging between the absolute values of **C047** and **C048** (motor 1, and relevant parameters for motor 2 and motor 3).

Max. absolute torque = Max(| **C047** | , | **C048** |)

Factory setting is **C147**=0: the reference source is disabled and the torque limit is given by the max. absolute torque.

36.1.5. REMOTE/LOCAL MODE

According to factory-setting, switching over from the **Remote** mode to the **Local** mode can only be made when the drive is disabled. The reference and command sources for the **Remote** mode depend on the settings of parameters **C140** to **C147** in the CONTROL METHOD MENU and on the settings of parameters **C285** to **C287** in the PID CONFIGURATION MENU. When switching over from the Remote mode to the Local mode, the command and reference can be sent via keypad only. This is true for the switch over from the **Local** to the **Remote** mode as well.

Parameter **C148** allows customizing the Loc/Rem function so that it can be performed even when the drive is running. Parameter **C148** also allows setting whether the same running condition and the same reference must be maintained when switching over from the Remote to the Local mode.



NOTE

For more details on the Loc/Rem function, see LOC/REM Key (Keypad Pages) and DIGITAL INPUTS MENU.

36.2. How to Manage the Reference Sources

This section covers how to manage the reference sources.

Two examples are given along with the table including the configuration of the parameters to be used.

Example 1: The Speed Reference is the algebraic sum of two references

Analog inputs REF and AIN1 (that are supposed to be 0-10V voltage inputs) are to be used as speed references. The main reference will be the sum of the two references being used. The end result may vary based on the parameters concerned.

P050	Type of Reference for REF Input	3: 0-10V
P051	Value of REF Input producing Min. Reference	0.0V
P051a	Percentage of Ref_Min producing Min. Reference	100.0%
P052	Value of REF Input producing Max. Reference	10.0V
P052a	Percentage of Ref_Max producing Max. Reference	100.0%
P055	Type of Signal over AIN1 input	3: 0-10V
P056	Value of AIN1 Input producing Min. Reference	0.0V
P056a	Percentage of Ref_Min producing Min. Reference	100.0%
P057	Value of AIN1 input producing Max. Reference	10.0V
P057a	Percentage of Ref_Max producing Max. Reference	100.0%
C028	Min. Motor Speed	0rpm
C029	Max. Motor Speed	1500rpm
C143	Selection of Reference 1	1: REF
C144	Selection of Reference 2	2: AIN1
C179	MDI for Source Selection	0: Disable

C179=0: Disable ensures that the main reference is the sum of the references being used. If a digital input for Source selection were used, either one reference would be selected as the main reference based on the input status. Both REF and AIN1 references are programmed in order to meet the following requirements:

- at 0V, they are expected to generate 100% of the minimum motor speed reference (**C028**), i.e. 0rpm
- at 10V, they are expected to generate 100% of the maximum motor speed reference (**C029**), i.e. 1500rpm

The main reference will be their sum and will start from 0rpm (when both references are at 0V) and its maximum value would be 3000rpm (when both references are at 10V), but it will be limited to 1500, as set by **C029**, as soon as the sum of the two references exceeds 1500rpm.

Suppose that the parameters below are to be programmed (only the parameters changing with respect to the example above are given):

C028	Min. Motor Speed	50rpm
-------------	------------------	-------

As the minimum motor speed is set to 50rpm, each of the two references, at 0V, will generate a reference equating 100% of 50rpm, i.e. 50rpm. The minimum value of the main reference, that is the sum of the two references, will then equate 100rpm if the two references are at 0V.

If the main reference shall start from 50rpm, that is it can generate the minimum motor speed, the following parameters shall be set accordingly:

P051a	Percentage of Ref_Min producing Min. Reference	50.0%
P056a	Percentage of Ref_Min producing Min. Reference	50.0%

In that way, either references at 0V will generate 50% of 50rpm, i.e. 25rpm. Their sum will be worth 50rpm at a minimum, as required.

If the whole resolution of the references is to be exploited, so that:

- at 0V, for both references, the minimum speed is 50rpm
- at 10V, for both references, the maximum speed is 1500rpm

then the following shall be programmed:

P052a	Percentage of Ref_Max producing Max. Reference	50.0%
P057a	Percentage of Ref_Max producing Max. Reference	50.0%



In that way, each reference will range from 25 to 750rpm and their sum will range from 50 and 1500rpm, as required.

Example 2: Speed references alternatively selected

The two REF analog inputs are to be used as alternative speed references. The following parameters shall be programmed accordingly:

P050	Type of Reference for REF Input	3: 0-10V
P051	Value of REF Input producing Min. Reference	0.0V
P051a	Percentage of Ref_Min producing Min. Reference	100.0%
P052	Value of REF Input producing Max. Reference	10.0V
P052a	Percentage of Ref_Max producing Max. Reference	100.0%
P055	Type of Signal over AIN1 input	3: 0-10V
P056	Value of AIN1 Input producing Min. Reference	0.0V
P056a	Percentage of Ref_Min producing Min. Reference	100.0%
P057	Value of AIN1 input producing Max. Reference	10.0V
P057a	Percentage of Ref_Max producing Max. Reference	100.0%
C143	Selection of Reference 1	1: REF
C144	Selection of Reference 2	2: AIN1
C179	MDI for Source Selection	6: MDI6

As MDI6 input is selected as reference source selection (**C179**), the references selected via **C143** and **C144** are selected as the main reference depending on the input status. When the input is inactive, REF will be the main reference; when the input is active, AIN1 will be the actual reference.

36.3. List of Parameters C140 to C148

Table 94: List of Parameters C140 to C148

Parameter	FUNCTION	User Level	MODBUS Address	Default Values
C140	Command digital input 1	ADVANCED	1140	1:Terminal Board
C141	Command digital input 2	ADVANCED	1141	1:Terminal Board
C142	Command digital input 3	ENGINEERING	1142	0
C143	Reference input 1	ADVANCED	1143	1: REF
C144	Reference input 2	ADVANCED	1144	2: AIN1
C145	Reference input 3	ENGINEERING	1145	0
C146	Reference input 4	ENGINEERING	1146	0
C147	Limit input	ENGINEERING	1147	0
C148	Switch over from Remote to Local command	ENGINEERING	1148	0: StandBy or Fluxing



NOTE

The programming range of parameters **C140**, **C141**, **C142** depends on the setting of parameter **C150** and vice versa (see the detailed description of the parameters above).

C140 (C141, C142) Command Source Selection 1 (2, 3)

C140 (C141, C142)	Range	0 ÷ 5	0: Disabled, 1: Terminal Board, 2: Serial Link, 3: Fieldbus, 4: Terminal Board B, 5: Keypad
	Default	C140 ÷ C141 = 1 C142 = 0	C140 ÷ C141 = 1: Terminal Board C142 = 0: Disabled
	Level	C140 ÷ C141 ADVANCED; C142 ENGINEERING	
	Address	1140 (1141,1142)	
	Function	Selection of the drive command source.	



NOTE

Setting one of the three command sources to 5: Keypad and one or more of the other command sources to different values from 5: Keypad is made possible only if:

1. STOP or STOP B digital inputs are set up (**C150** ≠ 0 or **C150a** ≠ 0) to enable using the pushbuttons or
2. the source selection function is selected (**C179** ≠ 0).



NOTE

If the digital input for source selection or command selection (parameter **C179** and **C179a** in the Digital Inputs Menu) is set to a value other than 0: Disabled, parameter **C142** (Command Source Selection 3) is always considered as OR bit by bit to the selected source. The ENABLE input (MDI2), however, is considered as AND to the selected source.

C143 (C144, C145, C146) Reference 1 (2, 3, 4) Selection

C143 (C144, C145, C146)	Range	0 ÷ 9 0 ÷ 11 if ES847 is in	0: Disabled 1: REF 2: AIN1 3: AIN2 4: Frequency input 5: Serial Link 6: Fieldbus 7: Keypad 8: Encoder 9: UpDown from MDI 10: XAIN4 11: XAIN5
	Default	C143 = 1, C144 = 2 C145 ÷ C146 = 0	C143 = 1: REF, C144 = 2: AIN1 C145 ÷ C146 = 0 : Disabled
	Level	C143 ÷ C144 ADVANCED; C145 ÷ C146 ENGINEERING	
	Address	1143 (1144, 1145, 1146)	
	Function	This parameter selects the sources for the speed (or torque) reference. The reference resulting from the sum of the selected sources represents the drive speed or torque reference. If the PID action has been set as reference C294 = Reference , the drive speed or torque references shall only be given by the PID output and not by the sources set in C143 ÷ C146 . Reference sources 10 and 11 can be selected only after setting XAIN in parameter R023 .	

C147 Limit Selection

C147	Range	0 ÷ 9 0 ÷ 11 if ES847 is in	0: Disabled 1: REF 2: AIN1 3: AIN2 4: Frequency input 5: Serial Link 6: Fieldbus 7: Keypad 8: Encoder 9: UpDown from MDI 10: XAIN4 11: XAIN5
	Default	0	0: Disabled
	Level	ENGINEERING	
	Address	1147	
	Control	VTC and FOC if Torque Limit; FOC if Speed Limit	
Function	If a speed control with VTC or FOC control algorithms is used, an external torque limit can be used: parameter C147 selects the Torque Limit source. The torque ramp times set in P026–P027 will be applied to the torque limit reference source that has been selected. The external torque limit may be disabled by closing the digital input set with C187 . With FOC control algorithm and C011=[2:Torque w/Speed Limit] parameter C147 selects the Speed Limit source. This selection is not available with VTC control algorithm. Limiting sources 10 and 11 can be selected only after setting XAIN in parameter R023 .		



NOTE

If the reference source is disabled, the torque limit results from the max. absolute torque determined by the drive size and the motor size.

The max. absolute torque is the max. value ranging between the absolute values of **C047** and **C048** (motor 1, and relevant parameters for motor 2 and motor 3).

Max. absolute torque = Max(| **C047** | , | **C048** |)

Factory-setting : the reference source is disabled (**C147**=0), so the torque limit depends on the max. absolute torque (see also the INPUTS FOR REFERENCES MENU).

C148 Switch over from Remote to Local Command

C148	Range	0 ÷ 3	0: StandBy + Fluxing 1: Drive Running / No Bumpless 2: Drive Running / Commands Bumpless 3: Drive Running / All Bumpless
	Default	0	0: StandBy or Fluxing
	Level	ENGINEERING	
	Address	1148	
	Function	<p>The drive factory-setting (0: StandBy or Fluxing) allows switching over from Remote to Local mode (and vice versa) only when the drive is not running. Different settings allowed by parameter C148 are detailed below; switching from Remote to Local mode (and vice versa) can be performed even when the drive is running:</p> <ul style="list-style-type: none"> • No Bumpless → When switching from Remote to Local mode, a “zero”[*] speed or torque reference is sent to the drive; the START button must be pressed to start the drive. • Commands Bumpless → When switching from Remote to Local mode, a “zero”[*] speed or torque reference is sent to the drive, but the running conditions are the same as in Remote mode. For example, if the motor is running in Remote mode, the drive still runs even in Local mode and the reference can be changed with the INC/DEC key, starting from “zero”. • All Bumpless → When switching from Remote to Local mode, the drive maintains the same speed/torque reference and the same running condition as in Remote mode. For example, if the motor is running at 1000 rpm in Remote mode, the drive still runs even in Local mode with a reference of 1000 rpm that can be changed with the INC/DEC key, starting from “zero”. <p>[*] Or to the smallest value compatible with C028/C029 or C047/C048.</p>	



NOTE

Parameter **C148** affects parameters **C140** to **C147** and **C285** to **C287** (see PID CONFIGURATION MENU) when the PID controller is enabled.

37. DIGITAL INPUTS MENU

37.1. Overview



NOTE Please refer to the Sinus Penta's Installation Guide for the hardware description of the digital inputs.

The parameters contained in this menu assign particular digital control functions to each digital input in the terminal board. Each parameter has a particular function, which is assigned to a given terminal on the terminal board.

Figure 51: Inputs that can be selected to implement control functions

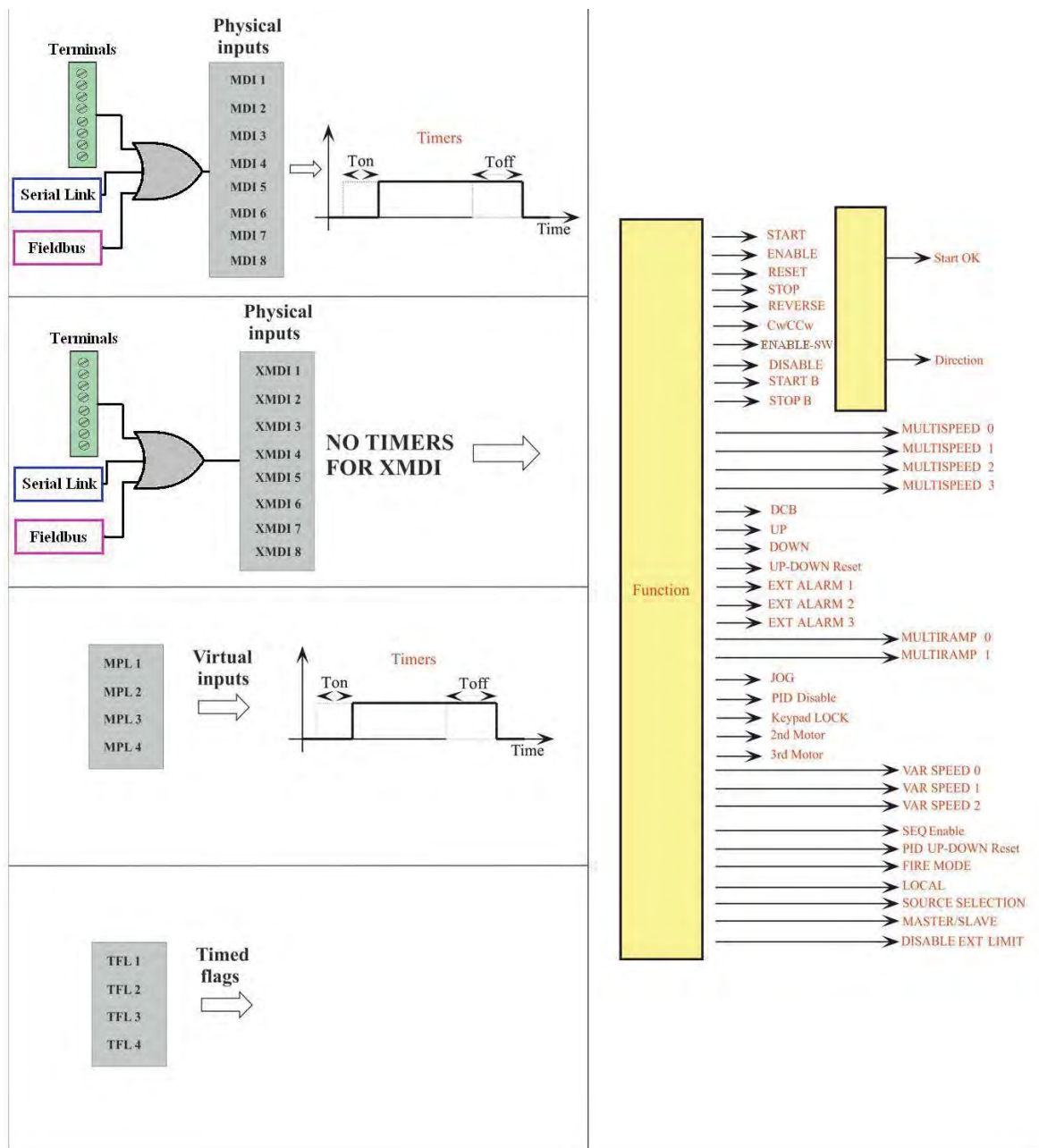



S000248



The full processing of the digital inputs also includes the selection of other remote/virtual terminal boards (see the CONTROL METHOD MENU) and the possibility of delaying input digital signal enable/disable by means of software timers (see the TIMERS MENU).

The digital input status is displayed in measures **M031**, **M032**, **M033**, **M034**, **M035**.

Measure **M033** shows the **current** status of the 8 inputs in the local hardware terminals in the drive board. The input called **MDI2&S** (“S” on the display keypad) is active only if both physical inputs **ENABLE-A** and **ENABLE-B** are active. The symbol  displays the logic levels for terminals **M033** for inactive inputs; the active inputs are marked with .

Measures **M034** and **M035** show the status of the terminal boards that can be activated via serial link and fieldbus respectively.

Measure **M032** shows the **current** status of the virtual terminal board obtained by processing all active terminal boards. It includes 10 signals, with two additional signals with respect to the local hardware terminal board:

- Inputs **MDI1** to **MDI8** are obtained with the **logic OR** of the input signals for all active terminals;
- The **ENABLE** function is obtained with the logic **AND** of the input signals for terminal **MDI2&S** (physical terminal board) and terminals **MDI2** (serial link and fieldbus) in all active terminal boards, unless parameter **C154a** is active.
- The **ENABLE-SW** function is obtained with the logic **AND** of the terminals selected for this function in all active terminal boards.

Measure **M031** is similar to **M032**, but it displays the status of the terminal board obtained after delaying the input signals of **M032** using special timers.

The drive uses this terminal board to acquire digital commands.

Some functions cannot be programmed, but they are assigned to special terminals:

Table 95: Unprogrammable functions

Function	Terminal
ENABLE	MDI2
RESET	MDI3 (can be disabled if C154=Yes)

Some terminals in the local hardware terminal board can also be used for different functions:

Table 96: Terminals used for other inputs

Terminal	Description
MDI6	ECHA: channel A of encoder A in the terminal board or FINA: frequency input
MDI7	ECHB: channel B of encoder A in the terminal board
MDI8	FINB: frequency input

37.1.1. START

The **START** function may be assigned to a digital input (MDI1..8); to an auxiliary digital input (XMDI1..8); to a virtual auxiliary digital output (MPL1..4) or to a timed flag (TFL1..4). The input programming is set via parameter **C149**.

To enable the Start input, set the control modes via terminal board (factory setting). The **START** command can also be sent from the display/keypad. The programmed input Enable/Disable can be delayed via special timers.

The **START** input function is assigned to MDI1 terminal by default, but it can be assigned to other terminals as well. The same terminal programmed as **START** may be allocated to different functions as well.

The motor stop mode (**C185**) can be programmed. When removing the **START** command, the following motor stop modes can activate:

the motor stops following a deceleration ramp or starts idling; the motor is fluxed (VTC, FOC) only when the **START** command is shut down and the **ENABLE** is not active (**C184**).

When **START** is **active** (and when the **ENABLE** function is active as well), the **RUN** command is enabled: the speed (or torque) *setpoint* increases proportionally to the preset ramp until it reaches the active *reference*. (IFD control: in order to enable the RUN command, the main speed reference must be other than zero).

When **START** is **inactive** (also when the **ENABLE** is active), the **RUN** command is disabled: the reference is set to zero and the speed (or torque) setpoint decreases down to zero depending on the preset deceleration ramp.

The way the **START** enables or disables the **RUN** command also depends on the setup of other functions, in particular the **STOP**, **REVERSE** and **JOG** functions (see parameters **C150**, **C151**, **C169**).

If the **REVERSE** (**C151**≠0) function is enabled, it can enable/disable the **RUN** command. However, if the **START** and **REVERSE** commands are both active, the **RUN** command is disabled.

NOTE

*In this case, **START** is interpreted as FORWARD and **REVERSE** as REVERSE. When both Start and Reverse are active, the system cannot interpret the query to be FORWARD or REVERSE.*

If the **JOG** function is enabled (**C169**≠0), it can enable/disable the **RUN** command, but only if the **RUN** command has not been previously enabled by other functions.

If the **STOP** function is enabled (**C150**≠0), the **RUN** command may be enabled/disabled only by pressing the relevant "key": see the description of the **STOP** function (**C150**).

NOTE

If only the keypad is enabled as the command source, press the **START** key located on the keypad to enable the drive **RUN** and press the **STOP** key to disable the drive **RUN**.

NOTE

If **C185** = Free Wheel when removing the **START** command, the drive will not carry out the deceleration ramp and will be put on stand-by.

37.1.2. ENABLE (TERMINALS 15:MDI2 AND S)

The **ENABLE** function is assigned to terminals **ENABLE-A (MDI2)** and **ENABLE-B (S)** (the series-connection of those inputs activates the **MDI2&S** input as displayed in **M033**) and **enables the drive operation**. It cannot be set to other terminals, whereas the same terminal may be assigned to different functions.

In order to enable the drive operation:

- **ENABLE-A** and **ENABLE-B** inputs must be active. In that way, **MDI2&S** displayed in measure **M033** will be active;
- **MDI2** input must be active on all active terminal boards (serial link and fieldbus – CONTROL METHOD MENU), unless parameter **C154a** is active.

The **ENABLE** function is detailed in the figure below. The command sources programmed in parameters **C140**, **C141**, **C142** are to be considered only when activated. See Table 90.

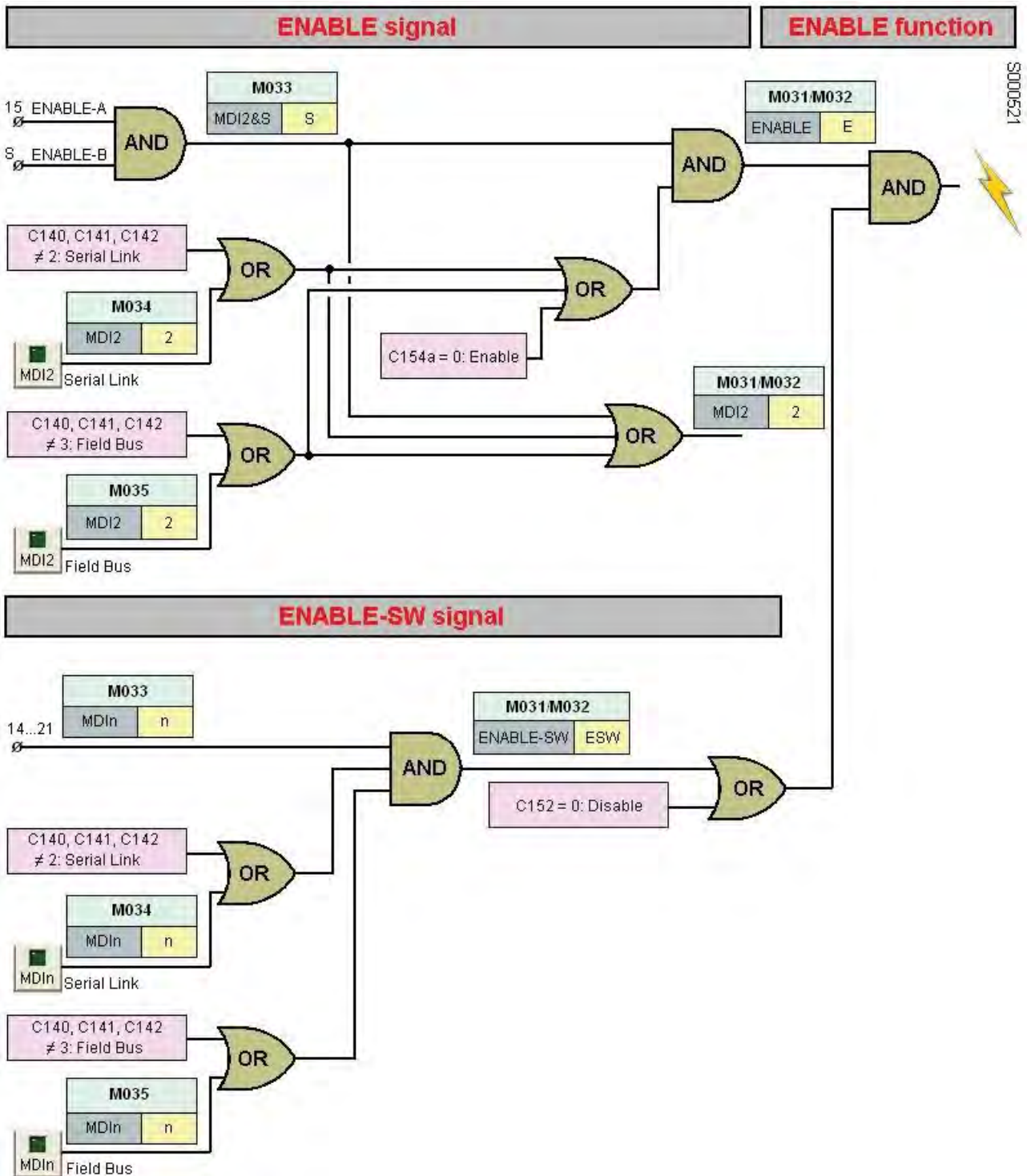

Figure 52: The ENABLE Function



NOTE

If the STO function is to be adopted, the control mode and the control circuit of the **ENABLE-A** and **ENABLE-B** signals must be accomplished as per the Safe Torque Off Function - Application Manual. That manual also includes a detailed validation procedure of the control configuration of the STO function to be executed upon first start-up and also periodically at yearly intervals.

If the **ENABLE** input is disabled, the drive output voltage is always set to zero, so the connected motor starts **idling** (the motor idles and stops due to friction or the mechanical load).

In case of pulled loads (e.g. hoisting applications), when the motor is idling, the mechanical load could cause the motor to run at uncontrolled speed!

If the **ENABLE** input is disabled when the drive is controlling the motor, it is closed with a delay time depending on the drive model. This **ENABLE** delay starts from the instant when the input is disabled irrespective of the enable delay (if any) set through a software timer in **MDI2**.

The operating mode and the logic used by the **ENABLE** input to enable/disable the drive also depends on the programming of the **DISABLE** and **ENABLE-SW** functions described below.

If the **IFD** control is used, the drive enabling also depends on the **START** input and the current value of the active reference: if the **START** command is active but the reference is lower than the preset threshold, the drive operation is disabled. To enable this operating mode with other types of control, parameters **P065** and **P066** must be set accordingly.

The drive may also be disabled by the **PID** regulator (see parameter **P255**).



DANGER!!!

The deactivation of the **ENABLE-SW** signal, the activation of the **DISABLE** signal, the deactivation of **MDI2** inputs from serial link or fieldbus DO NOT GUARANTEE that the Safe Torque Off – STO function is removed from the motor connected to the drive.

Safety stop conditions are guaranteed only when at least one of the two **ENABLE-A** and **ENABLE-B** inputs are opened.

For more details, consult the Safe Torque Off Function - Application Manual.



CAUTION

If the **MDI2** inputs are disabled for one of the active terminal boards, the drive is instantly disabled and the motor starts idling! If so, the mechanical load could cause uncontrolled acceleration/slowing down of the connected motor!



CAUTION

If the physical **ENABLE-A** or **ENABLE-B** inputs are opened, the drive is disabled and the motor starts idling! If this is the case, the mechanical load can cause uncontrolled acceleration/slowing down of the connected motor.



CAUTION

If a protection/alarm trips, the drive disables and the motor starts idling!

**NOTE**

If software timers are enabled for digital inputs, the timer for the **MDI2** input delays the signal enabling. The **ENABLE** signal is always instantly disabled (*for the **ENABLE** function, Toff in **MDI2** is ignored*).

**NOTE**

The activation of the **ENABLE** command enables the alarms controlling the configuration consistency of certain parameters.

**NOTE**

When the **ENABLE** function is active, C parameters cannot be changed (factory-setting). If **P003** Condition required for changing C parameters = Standby+Fluxing, the parameters may be changed even if the drive is enabled but the motor is not running.

**NOTE**

When the **ENABLE** function is active for VTC and FOC controls, the motor is fluxed by the drive. Motor fluxing is allowed only if the **START** contact is shut down and **C184** = Yes.

**NOTE**

If set accordingly, safety parameter **C181** prevents the drive from starting if the **ENABLE** function is already active when the drive is powered on.

37.1.3. RESET (TERMINAL 16:MDI3)

The **RESET** function is assigned to input terminal **MDI3**. It resets the alarms to unlock the drive operation. It cannot be set to other terminals, whereas the same terminal may be assigned to different functions. To disable the reset function from terminal MDI3, set **C154** = Yes.

If a protection trips, the drive locks, the motor starts idling (the motor idles and stops due to friction or the mechanical load) and an alarm message is displayed (see also the AUTORESET MENU and the ALARMS AND WARNINGS section).

Reset procedure

To unlock the drive, activate the **RESET** input for an instant, or press the **RESET** key from the keypad. When the drive unlocks and the cause responsible for the alarm has disappeared, "Inverter ok" comes up on the screen, otherwise, the alarm persists and cannot be reset.

If set up accordingly, safety parameter **C181** permits to deactivate and reactivate the **ENABLE** function to restart the drive once the cause responsible for the alarm has disappeared.

**NOTE**

Factory setting does not reset alarms at power off. Alarms are stored and displayed at next power on and the drive is locked. A manual reset is then required to unlock the drive (see the AUTORESET MENU).

**CAUTION**

If an alarm trips, see the ALARMS AND WARNINGS section and reset the equipment after detecting the cause responsible for the alarm.

**DANGER!!!**

Electrical shock hazard exists on output terminals (U, V, W) and resistive braking module terminals (+, -, B) even when the drive is disabled.

**NOTE**

Set **C154** = Yes to remove the reset function from MDI3. After that, only one different function can be allocated to MDI3 even when multiprogramming is active (see parameter **C182**).

37.2. Factory-setting of the Digital Inputs

Table 97: Terminal board: Factory-setting

Function	Terminal	Description
START	14: MDI1	Enables the drive RUN
ENABLE	15: MDI2&S	Enables the drive
RESET	16: MDI3	Resets the alarms tripped
MULTISPEED 0	17: MDI4	Bit 0 for Multispeed selection
MULTISPEED 1	18: MDI5	Bit 1 for Multispeed selection
Source Sel	19: MDI6	Source Selection
Loc/Rem	20: MDI7	Local / Remote Control Selection
CW/CCW	21: MDI8	Reference reversal

37.3. List of Parameters C149 to C188c and I006

The parameters ranging from **C149** to **C180** and from **C186** to **C188c** (one for each command function) activate single functions and set the terminal for each enabling/disabling function.

Parameter **C181** enables a safe **START** mode.

Parameter **C182** enables multiple programming (if compatible) to the same terminal. Max. two functions can be programmed to the same input.

Table 98: List of Parameters C149 to C188c and I006

Parameter	FUNCTION	User Level	MODBUS Address	Default Values
I006	Function selection for MDI control	ADVANCED	1393	inactive
C149	START Input	ADVANCED	1149	MDI1
C149a	START Input B	ADVANCED	1297	none
C150	STOP Input	ADVANCED	1150	none
C150a	STOP B Input	ADVANCED	1298	none
C151	REVERSE Input	ADVANCED	1151	none
C151a	REVERSE B Input	ADVANCED	1299	none
C152	ENABLE-SW Input	ADVANCED	1152	none
C153	DISABLE Input	ADVANCED	1153	none
C154	Disable RESET alarms on MDI3	ADVANCED	1154 bit 0	NO
C154a	ENABLE from Terminal Board Only	ADVANCED	1154 bit 1	NO
C155	MULTISPEED 0 Input	ADVANCED	1155	MDI4
C156	MULTISPEED 1 Input	ADVANCED	1156	MDI5
C157	MULTISPEED 2 Input	ADVANCED	1157	none
C158	MULTISPEED 3 Input	ADVANCED	1158	none
C159	CW/CCW Input	ADVANCED	1159	MDI8
C160	DCB Input	ADVANCED	1160	none
C161	UP Input	ADVANCED	1161	none
C162	DOWN Input	ADVANCED	1162	none
C163	RESET UP/DOWN Input	ADVANCED	1163	none
C164	External alarm 1 Input	ADVANCED	1164	none
C164a	External alarm 1 trip delay	ADVANCED	1305	immediate
C165	External alarm 2 Input	ADVANCED	1165	none
C165a	External alarm 2 trip delay	ADVANCED	1306	immediate
C166	External alarm 3 Input	ADVANCED	1166	none
C166a	External alarm 3 trip delay	ADVANCED	1307	immediate
C167	MultiRamp 0 Input	ENGINEERING	1167	none
C168	MultiRamp 1 Input	ENGINEERING	1168	none
C169	JOG Input	ADVANCED	1169	none
C169a	Input for Selection of Speed Regulator Parameters	ADVANCED	1233	none

Parameter	FUNCTION	User Level	MODBUS Address	Default Values
C170	SLAVE Input	ADVANCED	1170	none
C171	PID DISABLE Input	ADVANCED	1171	none
C171a	Input for PID control selection	ENGINEERING	1188	none
C172	KEYPAD LOCK Input	ADVANCED	1172	none
C173	MOTOR 2 SEL. Input	ENGINEERING	1173	none
C174	MOTOR 3 SEL. Input	ENGINEERING	1174	none
C175	SPEED VAR. 0 Input	ENGINEERING	1175	none
C176	SPEED VAR. 1 Input	ENGINEERING	1176	none
C177	SPEED VAR. 2 Input	ENGINEERING	1177	none
C178	PID RESET UP/DOWN input	ADVANCED	1178	none
C179	SOURCE SELECTION Input	ADVANCED	1179	MDI6
C179a	COMMAND SELECTION Input	ADVANCED	1238	none
C179b	REFERENCE SELECTION Input	ADVANCED	1239	none
C180	LOC/REM Input	ADVANCED	1180	MDI7
C180a	Type of LOC/REM contact	ADVANCED	1303	pushbutton+storage
C181	Safety Start enable	ADVANCED	1181	inactive
C182	Multiprogramming enable	ENGINEERING	1182	inactive
C183	Max. fluxing time before drive Disable	ADVANCED	1183	disabled
C184	Fluxing at activation only with START closed	ADVANCED	1184	no
C184a	Disable external torque limit during fluxing	ENGINEERING	1200	No
C185	Stop Mode	ADVANCED	1185	deceleration ramp
C186	Fire Mode enabling Input	ENGINEERING	1186	None
C187	Torque Limit Source Ref. Disabling Input	ADVANCED	1187	none
C187a	Multitorque 0 Input	ADVANCED	1094	None
C187b	Multitorque 1 Input	ADVANCED	1095	None
C188a	PID Multireference 1 Input	ENGINEERING	1365	none
C188b	PID Multireference 2 Input	ENGINEERING	1366	none
C188c	PID Multireference 3 Input	ENGINEERING	1367	none



NOTE If a parameter is set to zero, its function is disabled, otherwise the parameter value stands for the MDIx input assigned to the function.



NOTE Auxiliary digital inputs XMDI (values from 17 to 24 in control function parameters) can be set up only after setting XMDI/O in parameter **R023**.



CAUTION Set **C182=1** to allocate 2 functions to the same terminal.

I006 Function Selection for MDI Control

I006	Range	0 ÷ 2	0 → Inactive 1 → Clear all 2 → Set factory default
	Default	This is not a programming parameter: the input is set to zero whenever the drive is powered on and whenever the command is executed.	
	Level	ADVANCED	
	Address	1393	
	Function	0 → Inactive. 1 → Forces to “0 → Inactive” the settings of all the digital inputs. 2 → Forces to the default values the settings of all the digital inputs.	

C149 START Input

C149	Range	0 ÷ 16 0 ÷ 24 if ES847 or ES870 is fitted	0 → Inactive 1 ÷ 8 → MDI1 ÷ MDI8 9 ÷ 12 → MPL1 ÷ MPL4 13 ÷ 16 → TFL1 ÷ TFL4 17 ÷ 24 → XMDI1 ÷ XMDI8
	Default	1	MDI1
	Level	ADVANCED	
	Address	1149	
	Function	<p>When the START input is activated (the ENABLE-A and ENABLE-B inputs are activated as well), RUN is enabled: the speed (torque) <i>setpoint</i> increases following the programmed ramp until it reaches the active <i>reference</i>. In IFD control mode, <u>the main speed reference shall be other than zero for RUN enable.</u></p> <p>When the START input is inactive (even if the ENABLE-A and ENABLE-B inputs are activated) RUN is disabled: the reference is set to zero and the speed (torque) <i>setpoint</i> drops to zero based on the programmed deceleration ramp.</p>	



NOTE If the PROFIdrive option is present, parameter **C149 START Input** must be assigned to value 1: MDI1.

C149a START B Input

C149a	Range	0 ÷ 16 0 ÷ 24 if ES847 or ES870 is fitted	0 → Inactive 1 ÷ 8 → MDI1 ÷ MDI8 9 ÷ 12 → MPL1 ÷ MPL4 13 ÷ 16 → TFL1 ÷ TFL4 17 ÷ 24 → XMDI1 ÷ XMDI8
	Default	0	Inactive
	Level	ADVANCED	
	Address	1297	
	Function	The START B input behaves as the START input (see the START section) when terminal board B is active.	

C150 STOP Input

C150	Range	0 ÷ 16 0 ÷ 24 if ES847 or ES870 is fitted	0 → Inactive 1 ÷ 8 → MDI1 ÷ MDI8 9 ÷ 12 → MPL1 ÷ MPL4 13 ÷ 16 → TFL1 ÷ TFL4 17 ÷ 24 → XMDI1 ÷ XMDI8
	Default	0	Inactive
	Level	ADVANCED	
	Address	1150	
	Function	<p>This parameter disables the RUN function enabled by the START command.</p> <p>The setting of this function affects the enabling/disabling mode of the RUN command: it can be enabled/disabled using the START and STOP keys or the START, STOP and REVERSE keys instead of the START key as an ON/OFF switch (factory-setting).</p> <p><u>If the drive is enabled:</u> Press START to enable the drive RUN; Press STOP to disable the drive RUN: reference is set to zero, so the speed (or torque) setpoint decreases to zero based on the preset deceleration ramp.</p> <p>In case of preset STOP, the keypad and one or more terminal boards may be enabled at a time. In this case, the START key and the STOP key in the display/keypad are active and can enable or disable the drive RUN.</p> <p>The STOP input is a normally closed input signal.</p>	



NOTE

According to factory setting, only the hardware terminal board selected with command source 1 (**C140=1**) is active as a switch-operated mode (**C150=0**).
 To switch to the key-operated mode, set the **STOP** input (**C150 ≠0**). The keypad and other terminal boards may be selected in key-operated mode only.
 If the **STOP** input is not programmed, and the switch-operated mode is active, the keypad may be selected as the only command source (**C140=5**, **C141=0**, **C142=0**).



NOTE

The **STOP** function has priority over the **START** function; if both inputs are active, the **STOP** input prevails. Therefore, the **STOP** input acts as a key and as a **switch**.



NOTE

The **START/STOP** commands are ignored when the drive is disabled.

C150a STOP B Input

C150a	Range	0 ÷ 16 0 ÷ 24 if ES847 or ES870 is fitted	0 → Inactive, 1 ÷ 8 → MDI1 ÷ MDI8 9 ÷ 12 → MPL1 ÷ MPL4 13 ÷ 16 → TFL1 ÷ TFL4 17 ÷ 24 → XMDI1 ÷ XMDI8
	Default	0	Inactive
	Level	ADVANCED	
	Address	1298	
	Function	The STOP B Input acts as the STOP Input (see C150) when Terminal Board B is active. The STOP B is a normally closed input signal.	

C151 REVERSE Input

C151	Range	0 ÷ 16 0 ÷ 24 if ES847 or ES870 is fitted	0 → Inactive 1 ÷ 8 → MDI1 ÷ MDI8 9 ÷ 12 → MPL1 ÷ MPL4 13 ÷ 16 → TFL1 ÷ TFL4 17 ÷ 24 → XMDI1 ÷ XMDI8
	Default	0	Inactive
	Level	ADVANCED	
	Address	1151	
	Function	The REVERSE function carries out a START command, but it reverses the motor direction of rotation. If both the START and REVERSE inputs are active at the same time, the drive is sent a STOP command. If the STOP input function is not programmed (C150 =0), the REVERSE signal and the START input act as switches, otherwise they act as keys.	



NOTE

If the keypad is active, pressing the **FWD/REV** key on the display/keypad will also reverse the direction of rotation of the connected motor.
The reference direction of rotation can be reversed with **Cw/CCw** if this is set up (**C159** ≠ 0).
Both functions cause a signal reversal; if they are both active, they will cancel each other.



NOTE

The keypad and the terminal board can be simultaneously activated only if the **STOP** (**C150** ≠ 0) function is activated. Three sources for the signal reversal are then active: **REVERSE**, **Cw/CCw**, **REV** key; if two of them are active, they will cancel each other, while if all three sources are active, the reference sign will be reversed.



CAUTION

When the reference sign is reversed, the direction of rotation of the connected motor is not immediately reversed: the setpoint decreases to zero following the preset deceleration ramp, and it increases up to the reference value having the opposite sign following the preset acceleration ramp.

C151a REVERSE B Input

C151a	Range	0 ÷ 16 0 ÷ 24 if ES847 or ES870 is fitted	0 → Inactive 1 ÷ 8 → MDI1 ÷ MDI8 9 ÷ 12 → MPL1 ÷ MPL4 13 ÷ 16 → TFL1 ÷ TFL4 17 ÷ 24 → XMDI1 ÷ XMDI8
	Default	0	Inactive
	Level	ADVANCED	
	Address	1299	
	Function	The REVERSE B Input acts as the REVERSE Input (see C151) when Terminal Board B is active.	

The figure below illustrates the processing logic diagram for the **START**, **REV**, **Cw/CCw** functions and the **START**, **STOP**, **REV** keys on the display/keypad if the **STOP** function is not programmed.

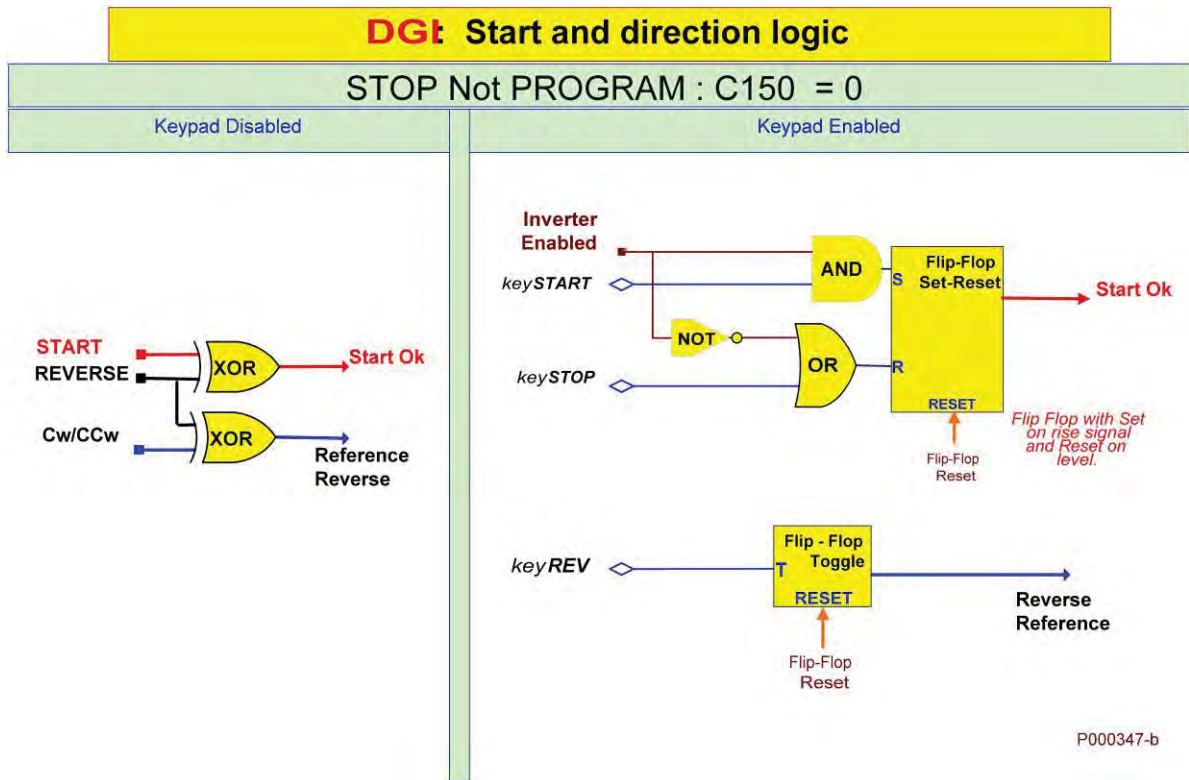

Figure 53: Controlling Run and Direction when the STOP Input is not programmed

The figure below illustrates the processing logic diagram for the **START, REV, Cw/CCw** functions and the **START, STOP, REV** keys on the display/keypad, if the **STOP** function is programmed.

DGI: Start and direction logic

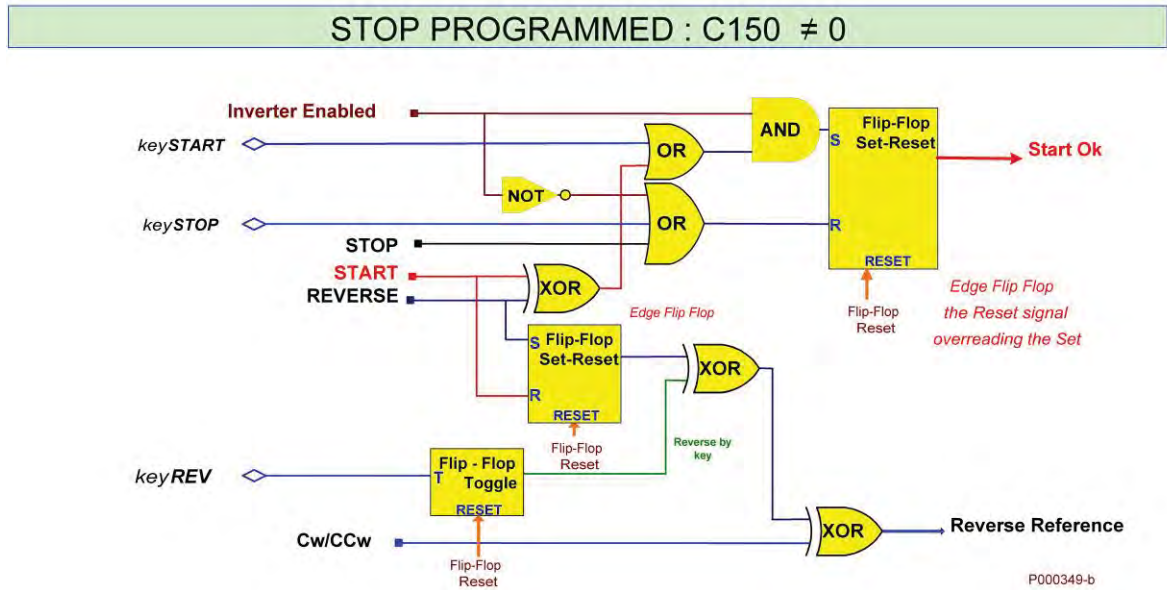

Figure 54: Controlling Run and Direction when the STOP Input is programmed

C152 ENABLE-SW Input

C152	Range	0 ÷ 16 0 ÷ 24 if ES847 or ES870 if fitted	0 → Inactive 1 ÷ 8 → MDI1 ÷ MDI8 9 ÷ 12 → MPL1 ÷ MPL4 13 ÷ 16 → TFL1 ÷ TFL4 17 ÷ 24 → XMDI1 ÷ XMDI8
	Default	0	Inactive
	Level	ADVANCED	
	Address	1152	
	Function	<p>This is an additional software-controlled Enable signal which is estimated in series to the ENABLE function associated to MDI2 inputs. If this function is enabled, the drive is enabled <i>if and only if</i> the ENABLE-A, ENABLE-B and ENABLE-SW inputs are simultaneously activated.</p> <p>If the ENABLE-SW function is programmed (C152≠0), do the following to enable the drive:</p> <ul style="list-style-type: none"> • activate the ENABLE-SW signal • activate the ENABLE-A and ENABLE-B signals • activate MDI2 inputs via serial link and fieldbus, if those inputs are selected via C140, C141, C142. • activate the DISABLE signal if programmed via C153. 	



NOTE

The **ENABLE-SW** signal may not be delayed by the timers: if a timer is programmed to the terminal related to the **ENABLE-SW** signal, this will not affect the **ENABLE-SW** function, while it normally delays other functions set to the same terminal.



DANGER!!!

The deactivation of the **ENABLE-SW** signal, the activation of the **DISABLE** signal, the deactivation of **MDI2** inputs from serial link or fieldbus DO NOT GUARANTEE that the Safe Torque Off – STO function is removed from the motor connected to the drive. Safety stop conditions are guaranteed only when at least one of the two **ENABLE-A** and **ENABLE-B** inputs are opened. For more details, consult the Safe Torque Off Function - Application Manual.

C153 DISABLE Input

C153	Range	0 ÷ 16 0 ÷ 24 if ES847 or ES870 is fitted	0 → Inactive 1 ÷ 8 → MDI1 ÷ MDI8 9 ÷ 12 → MPL1 ÷ MPL4 13 ÷ 16 → TFL1 ÷ TFL4 17 ÷ 24 → XMDI1 ÷ XMDI8
	Default	0	Inactive
	Level	ADVANCED	
	Address	1153	
	Function	The DISABLE function disables the drive and overrides any ENABLE-A and ENABLE-B signals. The DISABLE command sets the drive output voltage to zero, so the motor starts idling (the motor idles and stops due to friction or the mechanical load). If the DISABLE function is set up (C153 ≠0), do the following to enable the drive: <ul style="list-style-type: none"> • deactivate the input signal on the terminal selected via C153 • activate the ENABLE-A and ENABLE-B signals • activate the MDI2 inputs via serial link and fieldbus, if selected via C140, C141, C142 • activate the ENABLE-SW signal if programmed via C152. 	



DANGER!!!

The deactivation of the **ENABLE-SW** signal, the activation of the **DISABLE** signal, the deactivation of **MDI2** inputs from serial link or fieldbus DO NOT GUARANTEE that the Safe Torque Off – STO function is removed from the motor connected to the drive. Safety stop conditions are guaranteed only when at least one of the two **ENABLE-A** and **ENABLE-B** inputs are opened. For more details, consult the Safe Torque Off Function - Application Manual.

C154 Disable RESET Alarms on MDI3

C154	Range	0 ÷ 1	0: NO ; 1: Yes
	Default	0	0: NO
	Level	ADVANCED	
	Address	1154 bit 0	
	Function	If C154 =1 : Yes , the alarm reset function can be disabled from MDI3, that can be assigned to other functions.	

C154a ENABLE via Terminal Board Only

C154a	Range	0 ÷ 1	0: NO; 1: Yes
	Default	0	0: NO
	Level	ADVANCED	
	Address	1154 bit 1	
	Function	When C154a =1: Yes it is possible to force the system to consider the only terminal physical input as the ENABLE input, independently of the active command sources set in C140 , C141 , C142 .	



NOTE

Parameters **C154** and **C154a** may have binary values only and they share the same Modbus address. The bit-parameter match is given in the table below.

It is important to consider this if the address is updated from an external interface system: before writing a new value, read the address value and change the bit concerned only, to avoid changing the other parameter as well.

These precautions are not necessary for the changes made via keypad or RemoteDrive.

Table 99: Coding of Parameters C154 and C154a

bit [15..2]	bit [1]	bit [0]
not used	C154a	C154

C155, C156, C157, C158 MULTISPEED Inputs

C155 C156 C157 C158	Range	0 ÷ 16 0 ÷ 24 if ES847 or ES870 is fitted	0 → Inactive 1 ÷ 8 → MDI1 ÷ MDI8 9 ÷ 12 → MPL1 ÷ MPL4 13 ÷ 16 → TFL1 ÷ TFL4 17 ÷ 24 → XMDI1 ÷ XMDI8
	Default	C155 = 4, C156 = 5, C157 = 0, C158 = 0.	C155 = MDI4, C156 = MDI5, C157 = C158 = Inactive.
	Level	ADVANCED	
	Address	1155, 1156, 1157, 1158	
Function		<p>This function generates up to 15 speed references that can be programmed with parameters P081+P098 according to the programming mode set in P080.</p> <p>The 4 Multispeed functions determine which of the 15 active speed references are active: active value (1) or inactive value (0) of each preset input signal determines a bit-logic binary number: MULTISPEED 0 is the least significant bit (bit 0) and MULTISPEED 3 is the most significant bit (bit 3).</p> <p>If one of these functions is not set up, its relevant bit is “zero”.</p>	

Table 100: Multispeed selection

Multispeed selected =	Bit 3	Bit 2	Bit 1	Bit 0
	MULTISPEED 3	MULTISPEED 2	MULTISPEED 1	MULTISPEED 0

Table 101: Selected Speed reference

Function:	Status of the relevant input																
START	0	1	1	1	1	1	1	1	1	1	1	1	1	1	1	1	
MULTISPEED 0	X	0	1	0	1	0	1	0	1	0	1	0	1	0	1	0	1
MULTISPEED 1	X	0	0	1	1	0	0	1	1	0	0	1	1	0	0	1	1
MULTISPEED 2	X	0	0	0	0	1	1	1	1	0	0	0	0	1	1	1	1
MULTISPEED 3	X	0	0	0	0	0	0	0	0	1	1	1	1	1	1	1	1
Multispeed selected	X	0	1	2	3	4	5	6	7	8	9	10	11	12	13	14	15
Resulting reference	0	(*)	P081	P083	P085	P087	P088	P089	P090	P091	P092	P093	P094	P095	P096	P097	P098

If one of these functions is not set up, its relevant bit is “zero”.
 For example, if **C156** and **C157** are Inactive (0), while **C155** and **C158** are programmed to two different terminals, only Multispeed 0, 1, 8, 9 can be selected, relating to the following references:

(*)	P081	P091	P092
-----	------	------	------

(*) Factory-setting: (**P080 = Preset Speed**) if no Multispeed function is selected, the active reference is the reference set according to the parameters in the INPUTS FOR REFERENCES MENU.
 If **P080 = Speed Sum**, the selected Multispeed function **adds up** to the active reference: the reference set according to the parameters in the INPUTS FOR REFERENCES MENU.

If **P080 = Preset Speed Esc**, the selected Multispeed **replaces** the active reference, which will be ignored. If no Multispeed function is selected, the resulting reference is equal to zero.

See also the INPUTS FOR REFERENCES MENU for the reference processing sequence: the **Speed Decrease** function and the **Reference Reversal** function become active downstream of the **Multispeed** function.



NOTE

In Table 101:
0 ⇒ Inactive input;
1 ⇒ Active input;
X ⇒ Input having no effect.

C159 CW/CCW Input

C159	Range	0 ÷ 16 0 ÷ 24 if ES847 or ES870 is fitted	0 → Inactive 1 ÷ 8 → MDI1 ÷ MDI8 9 ÷ 12 → MPL1 ÷ MPL4 13 ÷ 16 → TFL1 ÷ TFL4 17 ÷ 24 → XMDI1 ÷ XMDI8
	Default	8	MDI8
	Level	ADVANCED	
	Address	1159	
	Function	The CW/CCW function reverses the active reference signal : the connected motor decelerates to zero following the preset deceleration ramp, then it accelerates following the preset acceleration ramp until it reaches the new reference value.	

C160 DCB Input

C160	Range	0 ÷ 16 0 ÷ 24 if ES847 or ES870 is fitted	0 → Inactive 1 ÷ 8 → MDI1 ÷ MDI8 9 ÷ 12 → MPL1 ÷ MPL4 13 ÷ 16 → TFL1 ÷ TFL4 17 ÷ 24 → XMDI1 ÷ XMDI8
	Default	0	Inactive
	Level	ADVANCED	
	Address	1160	
	Control	IFD and VTC	
Function	For FOC control, this function has no effect even if C160 ≠0. The DCB command enables DC braking at stop for a time period depending on the speed value determining the input activation. See the DC Braking Command Sent from Digital Input for more details.		

C161, C162 UP and DOWN Inputs

C161 C162	Range	0 ÷ 16 0 ÷ 24 if ES847 or ES870 is fitted	0 → Inactive 1 ÷ 8 → MDI1 ÷ MDI8 9 ÷ 12 → MPL1 ÷ MPL4 13 ÷ 16 → TFL1 ÷ TFL4 17 ÷ 24 → XMDI1 ÷ XMDI8
	Default	0	Inactive
	Level	ADVANCED	
	Address	1161, 1162	

	Function	<p>This function increases (UP) or decreases (DOWN) the reference for which the UpDown source from MDI has been selected by adding a quantity to the reference itself. This also depends upon the following parameters:</p> <ul style="list-style-type: none">C163 Up/Down ResetP067 Up/Down Ramp TimeP068 Store Up/Down value at power offP068a Speed/Torque Up/Down Reset at stopP068b PID Up/Down Reset at stopP068c Speed/Torque Up/Down Reset at sources changeoverP068d PID Up/Down Reset at sources changeoverP069 Up/Down Reference range
--	-----------------	---

C163 Reset Up/Down Input for Speed/Torque Reference

C163	Range	0 ÷ 16 0 ÷ 24 if ES847 or ES870 is fitted	0 → Inactive 1 ÷ 8 → MDI1 ÷ MDI8 9 ÷ 12 → MPL1 ÷ MPL4 13 ÷ 16 → TFL1 ÷ TFL4 17 ÷ 24 → XMDI1 ÷ XMDI8
	Default	0	Inactive
	Level	ADVANCED	
	Address	1163	
	Function	This function sets to zero the reference variation obtained via the UP or DOWN inputs or the ▲ and ▼ keys located on the display/keypad. The Up/Down reference (Speed/Torque only) may also be reset using different functions (see P068a – P068c).	

C164 , C165, C166 External Alarm Inputs

C164 C165 C166	Range	0 ÷ 16 0 ÷ 24 if ES847 or ES870 is fitted	0 → Inactive 1 ÷ 8 → MDI1 ÷ MDI8 9 ÷ 12 → MPL1 ÷ MPL4 13 ÷ 16 → TFL1 ÷ TFL4 17 ÷ 24 → XMDI1 ÷ XMDI8
	Default	0	Inactive
	Level	ADVANCED	
	Address	1164, 1165, 1166	
	Function	When allocating one of these 3 functions to a digital input, the status of this input will ALWAYS BE CHECKED ON THE DRIVE'S TERMINAL BOARD . When the command contact opens, the drive is locked due to an alarm tripped. Parameters C164a, C165a, C166a allow delaying external alarms. To restart the drive, the digital input set as an external alarm must be closed and a Reset procedure is required. Alarms tripped due to these 3 functions are A083, A084, A085 respectively. This function is factory set as disabled.	



CAUTION

The terminal board for these 3 functions is the hardware terminal board of the drive. If different command sources are enabled (see the CONTROL METHOD MENU), the "External Alarm" signal command is obtained only for the hardware terminal board of the drive. Therefore, in order to avoid any external alarm, the input signal for the active terminal must be active in the terminal board.

Alarms trip when only one input signal for the terminal selected on one of the active command sources is disabled. A trip delay can be programmed with parameters **C164a, C165a, C166a**.

C164a (C165a, C166a) External Alarm Trip Delay

C164a C165a C166a	Range	0 ÷ 32000	0 ÷ 32000 msec
	Default	0	Instantaneous
	Level	ADVANCED	
	Address	1305, 1306, 1307	
	Function	External alarm trip delay. To avoid untimely alarm trip, it may be necessary to set a check time for the opening of the input set as an external alarm before the alarm trips.	

C167, C168 MULTIRAMP Inputs

C167 C168	Range	0 ÷ 16 0 ÷ 24 if ES847 or ES870 is fitted	0 → Inactive 1 ÷ 8 → MD11 ÷ MD18 9 ÷ 12 → MPL1 ÷ MPL4 13 ÷ 16 → TFL1 ÷ TFL4 17 ÷ 24 → XMD11 ÷ XMD18
	Default Level	0	Inactive
	Address	ENGINEERING	
	Function	1167, 1168	
	Function	This function allows selecting up to 4 acceleration/deceleration ramps . Each ramp has its own programming parameters; see P009 ÷ P025 (RAMPS MENU) . These 2 functions determine which of the 4 ramps is to be selected: the active value (1) or inactive value (0) of each preset input signal determines a binary number with a bit-logic, where Multiramp 0 is the least significant bit (bit 0) and Multiramp 1 is the most significant bit (bit 1). The ramps range from 1 to 4; for the selected ramp, add 1 to the binary figure obtained. If one of these functions is not programmed, the relevant bit is "zero".	

Table 102: Multiramp selection

$$\text{Selected Ramp} = \left(\begin{array}{|c|c|} \hline \text{Bit 1} & \text{Bit 0} \\ \hline \text{Multiramp 1} & \text{Multiramp 0} \\ \hline \end{array} \right) + 1$$

Table 103: Selected ramp

Function:	Input Status			
Multiramp 0	0	1	0	1
Multiramp 1	0	0	1	1
Selected Ramp	1	2	3	4
Active ramp times (parameters determining the ramp model)	P009 P010 P014 (*)	P012 P013 P014 (*)	P015 P016 P020 (*)	P018 P019 P020 (*)

If one of these functions is not programmed, its bit is "zero".
 For example, if **C167** is Inactive (0) and **C168** is programmed for one terminal, only ramp 1 or ramp 3 can be selected.



NOTE (*)

If the ramp rounding off function is enabled (**P021≠0**), the actual ramp times also depend on the values set in parameters **P022, P023, P024, P025, P031**.

C169 JOG Input

C169	Range	0 ÷ 16 0 ÷ 24 if ES847 or ES870 is fitted	0 → Inactive 1 ÷ 8 → MDI1 ÷ MDI8 9 ÷ 12 → MPL1 ÷ MPL4 13 ÷ 16 → TFL1 ÷ TFL4 17 ÷ 24 → XMDI1 ÷ XMDI8
	Default	0	Inactive
	Level	ADVANCED	
	Address	1169	
	Function	When the JOG function is enabled, the motor rotates at low speed following slow ramps which are manually controlled by the user only by means of the keys in keypad. If the drive is enabled (ENABLE function activated) but is not running, and if the JOG terminal is enabled, the drive will run: the connected motor will accelerate following a JOG ramp (P029) up to the JOG speed reference (P070). On the other hand, if the terminal is disabled, the drive will stop: the connected motor will decelerate to zero speed following the JOG ramp (P029). Reverse the direction of rotation of the active reference to reverse the JOG reference.	



CAUTION

The motor starts running as soon as this terminal is activated (only if the drive is enabled).



NOTE

The **RUN** function will override the **JOG** function. Therefore, if the **RUN** function is active, the **JOG** function is ignored.



NOTE

If the motor is not running in **SLAVE mode** (torque reference instead of speed reference), it can rotate at JOG speed when the user activates the **JOG** function. In **SLAVE mode**, the **JOG** function is ignored if the motor is still rotating due to an active reference torque.

C169a Input for Selection of Speed Regulator Parameters

C169a	Range	0 ÷ 16 0 ÷ 24 if ES847 or ES870 is fitted	0 → Inactive 1 ÷ 8 → MDI1 ÷ MDI8 9 ÷ 12 → MPL1 ÷ MPL4 13 ÷ 16 → TFL1 ÷ TFL4 17 ÷ 24 → XMDI1 ÷ XMDI8
	Default	0	Inactive
	Level	ADVANCED	
	Address	1233	
	Control	FOC	
	Function	This function allows switching between the two parameter sets pertaining to the speed regulator. The two pairs of parameters concerned are the same as the parameters activating in case of automatic regulation based on the speed error (see SPEED LOOP AND CURRENT BALANCING MENU). For example, parameters P126/P128 and P125/P129 apply to Motor 1 . Always referring to Motor 1 , a low logic level of the input associated to the selector keeps parameters P126/P128 active, while a high logic level affects speed regulation via parameters P125/P129 . This applies to Motor 2 and Motor 3 as well for parameters P136/P138 and P135/P139 for Motor 2 , or P146/P148 and P145/P149 for Motor 3 .	

C170 SLAVE Input

C170	Range	0 ÷ 16 0 ÷ 24 if ES847 or ES870 is fitted	0 → Inactive 1 ÷ 8 → MDI1 ÷ MDI8 9 ÷ 12 → MPL1 ÷ MPL4 13 ÷ 16 → TFL1 ÷ TFL4 17 ÷ 24 → XMDI1 ÷ XMDI8
	Default	0	Inactive
	Level	ADVANCED	
	Address	1170	
	Control	VTC and FOC	
	Function	When activating the terminal allocated to the Slave Input, the main reference becomes a torque reference and the speed loop is by-passed. This function enables the <i>SLAVE</i> operating mode (torque reference), instead of the <i>MASTER</i> operating mode (speed reference); the <u>Torque References</u> and the <u>Ramp Torques</u> are used (see the INPUTS FOR REFERENCES MENU and the RAMPS MENU).	



NOTE

This function is ignored if the operating mode selected for the active motor is the *SLAVE* mode, i.e. **C011 (C054, C097) =1:Torque oppure =2:Torque w/Speed Limit**.

Commands are factory-set to *MASTER* mode and the speed reference is selected as factory setting (**C011 (C054, C097) =0: Speed**).



NOTE

Enabling this function means setting **C011 (C054, C097) =1:Torque**, not =2:Torque w/Speed Limit.

C171 PID DISABLE Input

C171	Range	0 ÷ 16 0 ÷ 24 if ES847 or ES870 is fitted	0 → Inactive 1 ÷ 8 → MDI1 ÷ MDI8 9 ÷ 12 → MPL1 ÷ MPL4 13 ÷ 16 → TFL1 ÷ TFL4 17 ÷ 24 → XMDI1 ÷ XMDI8
	Default	0	Inactive
	Level	ADVANCED	
	Address	1171	
	Function	This function is used for managing the PID regulator (see the PID CONFIGURATION MENU). When the terminal allocated to this function is activated, the <u>PID regulator can be disabled</u> : its output and its external variable are set to zero. More precisely, if the PID regulator is in External Out mode (C294=0), when the PID DISABLE function is enabled, the PID output is set to zero and the external variable regulated by the PID regulator (feedback) <u>is no longer regulated by the PID regulator itself</u> . In Reference mode, the PID DISABLE function <u>disables the PID regulator as described above and switches the reference</u> , thus <u>becoming the main active reference again</u> .	

C171a Input for PID Control Selection

C171a	Range	0 ÷ 16 0 ÷ 24 if ES847 or ES870 is fitted	0 → Inactive 1 ÷ 8 → MDI1 ÷ MDI8 9 ÷ 12 → MPL1 ÷ MPL4 13 ÷ 16 → TFL1 ÷ TFL4 17 ÷ 24 → XMDI1 ÷ XMDI8
	Default	0	Inactive

	Level	ENGINEERING
	Address	1188
	Function	This parameter pertains to the activation of the two PIDs or the 2-zone mode (see the PID CONFIGURATION MENU). It allows using the PID regulator outputs in different ways and allows disabling the 2-zone mode.

C172 KEYPAD LOCK Input

C172	Range	0 ÷ 16 0 ÷ 24 if ES847 or ES870 is fitted	0 → Inactive 1 ÷ 8 → MDI1 ÷ MDI8 9 ÷ 12 → MPL1 ÷ MPL4 13 ÷ 16 → TFL1 ÷ TFL4 17 ÷ 24 → XMDI1 ÷ XMDI8
	Default	0	Inactive
	Level	ADVANCED	
	Address	1172	
	Function	This function avoids accessing parameter modification through the removable display/keypad and avoids accessing the LOCAL mode by pressing the LOC/REM key or by enabling the LOCAL input function (C181).	



NOTE

If the **LOCAL** mode is already active, the **LOCK** command will have no effect on the **LOCAL** function: it only avoids changing the programming parameters, while it is still possible to send references and the **START/STOP/REV/JOG/RESET** commands via keypad.

If the **LOCK** command is active and the **LOCAL mode** is disabled, the **LOCK** function prevents the LOCAL mode from activating.

C173, C174 MOTOR SEL Input

C173 C174	Range	0 ÷ 16 0 ÷ 24 if ES847 or ES870 is fitted	0 → Inactive 1 ÷ 8 → MDI1 ÷ MDI8 9 ÷ 12 → MPL1 ÷ MPL4 13 ÷ 16 → TFL1 ÷ TFL4 17 ÷ 24 → XMDI1 ÷ XMDI8
	Default	0	Inactive
	Level	ENGINEERING	
	Address	1173, 1174	
	Function	This function activates motor 2 and 3 and sets the relevant programming parameters (see Table 104). A different active motor can be selected only when the drive is disabled.	

Table 104: Motor selection

Value of the terminal allocated to the Sel. Motor n.2 (C173) function	Value of the terminal allocated to the Sel. Motor n.3 (C174) function	Active motor
0	0	Motor n.1
1	0	Motor n.2
0	1	Motor n.3
1	1	Motor n.1



NOTE

When both inputs are enabled, Motor 1 is selected again.

C175, C176, C177 SPEED VAR. Inputs

C175 C176 C177	Range	0 ÷ 16 0 ÷ 24 if ES847 or ES870 is fitted	0 → Inactive 1 ÷ 8 → MDI1 ÷ MDI8 9 ÷ 12 → MPL1 ÷ MPL4 13 ÷ 16 → TFL1 ÷ TFL4 17 ÷ 24 → XMDI1 ÷ XMDI8
	Default	0	Inactive
	Level	ENGINEERING	
	Address	1175, 1176, 1177	
Function	This function generates up to 7 values of variation % for the active reference ranging from –100% to 100% with parameters P115÷P121 . The 3 functions determine which of the 7 values of the speed reference variation is active: the active value (1) or inactive value (0) of each preset input signal determines a bit-logic binary number where SPEED VAR. 0 is the least significant bit (bit 0), while SPEED VAR. 2 is the most significant bit (bit 3) as shown in Table 105 and Table 106. If one of these functions is not set up, its bit is "zero".		

Table 105: Selection of the speed reference variation

Variation of the Selected Speed Reference =	Bit 2	Bit 1	Bit 0
	SPEED VARIATION 2	SPEED VARIATION 1	SPEED VARIATION 0

Table 106: Variation of the selected speed reference

Function:	Input Status							
MULTISPEED 0	0	1	0	1	0	1	0	1
MULTISPEED 1	0	0	1	1	0	0	1	1
MULTISPEED 2	0	0	0	0	1	1	1	1
Variation of the selected speed reference	None	1	2	3	4	5	6	7
Variation % selected	0	P115	P116	P117	P118	P119	P120	P121

If one of the functions above is not set up, its bit is "zero".

For example, if **C175** and **C177** are INACTIVE (0) and **C176** is programmed for one terminal, only variation 2 corresponding to parameter **P116** can be selected.

In any case, the output speed must never exceed the max. allowable speed, even when a higher speed is required.



NOTE

In Table 106 above:
0 ⇒ Inactive Input;
1 ⇒ Active Input.

C178 PID Up/Down Reset Input

C178	Range	0 ÷ 16 0 ÷ 24 if ES847 or ES870 is fitted	0 → Inactive 1 ÷ 8 → MDI1 ÷ MDI8 9 ÷ 12 → MPL1 ÷ MPL4 13 ÷ 16 → TFL1 ÷ TFL4 17 ÷ 24 → XMDI1 ÷ XMDI8
	Default	0	Inactive
	Level	ADVANCED	
	Address	1178	
	Function	This function resets the variation of the PID reference obtained with the ▲ and ▼ keys on the KEYPAD page of the user interface on the display/keypad in PID mode.	

C179 Source Selection Input

C179	Range	0 ÷ 16 0 ÷ 24 if ES847 or ES870 is fitted	0 → Inactive 1 ÷ 8 → MDI1 ÷ MDI8 9 ÷ 12 → MPL1 ÷ MPL4 13 ÷ 16 → TFL1 ÷ TFL4 17 ÷ 24 → XMDI1 ÷ XMDI8
	Default	6	MDI6
	Level	ADVANCED	
	Address	1179	
	Function	<p>The digital input set as a source selector is considered in the drive terminal board only, not in the virtual terminal boards, as Fieldbus or Serial Link (see Command Sources).</p> <p>When the digital input set as a source selector is <u>open</u>, only the first command sources and references programmed in the CONTROL METHOD MENU are considered (C140 command source n.1 and C143 reference source n.1 respectively) as well as the first reference and feedback sources programmed in the PID CONFIGURATION MENU (parameter C285 for reference source n. 1 and C288 for feedback source n.1).</p> <p>When the digital input set as a source selector is <u>closed</u>, only the second command source and the second reference source programmed in the CONTROL METHOD MENU are considered (C141 for command source n. 2 and C144 for reference source n.2), as well as the second reference sources and feedback sources set in the PID CONFIGURATION MENU (parameter C286 for reference source n.2 and parameter C289 for feedback source n.2).</p>	



CAUTION

If set different from 0:Disabled, reference sources n.3 (**C145** in the CONTROL METHOD MENU and **C287** and **C290** in the PID CONFIGURATION MENU) and reference sources n.4 (**C146** in the CONTROL METHOD MENU) are always considered as summed up to the reference source selected by the source selector.



CAUTION

Command source n.3 (**C142** in the CONTROL METHOD MENU), if programmed other than 0: Disabled, is always considered as OR bit by bit to the one selected by the selector. The ENABLE input (MDI2), however, is considered as AND to the selected source.



CAUTION

C179 programming is exclusive in respect to **C179a** and **C179b** and viceversa. If **C179** is ≠ 0, neither **C179a** nor **C179b** may be programmed. If **C179a** and **C179b** are not both set to 0, **C179** may not be programmed.

C179a Input for Source Selection

C179a	Range	0 ÷ 16 0 ÷ 24 if ES847 or ES870 is fitted	0 → Inactive 1 ÷ 8 → MDI1 ÷ MDI8 9 ÷ 12 → MPL1 ÷ MPL4 13 ÷ 16 → TFL1 ÷ TFL4 17 ÷ 24 → XMDI1 ÷ XMDI8
	Default	0	Inactive
	Level	ADVANCED	
	Address	1238	
	Function	<p>Programming this parameter is an alternative to programming C179. Make sure that C179 is set to zero before setting up C179a. The digital input set as Command selector is considered only in the drive terminal board and not in the virtual terminal boards, such as Fieldbus or Serial Links (see Command Sources).</p> <p>By programming a digital input as Command Selector, when this is not active (relevant MDI open in the terminal board) only the first control board C140 programmed in the CONTROL METHOD MENU is considered.</p> <p>When the MDI programmed in C179a is closed, only the second command source C141 programmed in the CONTROL METHOD MENU is considered.</p>	



CAUTION

Command source n.3 (**C142** in the CONTROL METHOD MENU), if set to value other than 0: Disabled, is always considered as OR bit by bit to the selected source. The ENABLE input (MDI2), however, is considered as AND to the selected source.

C179b Input for Reference Selection

C179b	Range	0 ÷ 16 0 ÷ 24 if ES847 or ES870 is fitted	0 → Inactive 1 ÷ 8 → MDI1 ÷ MDI8 9 ÷ 12 → MPL1 ÷ MPL4 13 ÷ 16 → TFL1 ÷ TFL4 17 ÷ 24 → XMDI1 ÷ XMDI8
	Default	0	Inactive
	Level	ADVANCED	
	Address	1239	
	Function	<p>Programming this parameter is an alternative to programming C179. Make sure that C179 is set to zero before setting up C179b. The digital input set as Reference selector is considered only in the drive terminal board and not in the virtual terminal boards, such as Fieldbus or Serial Links (see Command Sources).</p> <p>By programming a digital input as Source Selector, when this is not active (relevant MDI open in the terminal board) only the first control board C143 programmed in the CONTROL METHOD MENU is considered, as well as the first reference and feedback source in the PID CONFIGURATION MENU (C285 Reference Source N.1 and C288 Feedback Source N.1 respectively).</p> <p>When the MDI programmed in C179b is closed, only the second command source C144 programmed in the CONTROL METHOD MENU is considered, as well as the second reference and feedback source in the PID CONFIGURATION MENU (C286 Reference Source N.2 and C289 Feedback Source N.2 respectively).</p>	

C180 LOC/REM Input

C180	Range	0 ÷ 16 0 ÷ 24 if ES847 or ES870 is fitted	0 → Inactive 1 ÷ 8 → MDI1 ÷ MDI8 9 ÷ 12 → MPL1 ÷ MPL4 13 ÷ 16 → TFL1 ÷ TFL4 17 ÷ 24 → XMDI1 ÷ XMDI8
	Default Level	7	MDI7
	Address	1180	
	Function	<p>The digital input set as a source selector is considered in the drive terminal board only, not in the virtual terminal boards, as Fieldbus or Serial Link (see Command Sources).</p> <p>The LOCAL mode can be enabled via the relevant digital input (it ignores any enabling/disable delay times set via software timers) or by pressing the LOC/REM key located on the display/keypad.</p> <p>Factory setting allows enabling the Local mode only when the drive is not running. Settings may be changed through C148 Changeover from Remote to Local Command (see the CONTROL METHOD MENU); switching from Remote to Local command is allowed even when the drive is operating and when the running condition or reference must be maintained in Local mode.</p> <p>This function allows switching over to LOCAL mode and allows ignoring parameters C140 to C147 and C285 to C287 (see the PID CONFIGURATION MENU) when the PID controller is enabled, thus allowing setting them via KEYPAD only.</p> <p>The following functions are still active in the hardware terminal board of the control board being used: ENABLE, External Alarm 1,2,3, Sel.Motor n.2, Sel.Motor n.3, SLAVE, PID Disable, and the LOCAL function itself, that can be disabled at any time. If the input is deactivated when the drive is disabled, signals coming from different sources will activate again.</p> <p>If the main reference of the drive is the PID output, you can set C180a Type of LOC/REM Contact = Pushbutton and P266 Type of Keypad page in Local Mode = Ref.Activated + Spd. As a result, when the Loc key is pressed and released once, the drive enters the Local mode and the PID reference can be changed, whereas when the Loc command is pressed and released again (provided that the drive is not enabled) the PID is disabled and the RPM reference can be sent to the connected motor. See also the CONTROL METHOD MENU and the Keypad page and Local mode in the DISPLAY/KEYPAD menu.</p>	

C180a Type of LOC/REM Contact

C180a	Range	0 ÷ 2	0:[Switch] 1:[Pushbutton] 2:[Pushbutton+Storage]
	Default Level	2	2:[Pushbutton+Storage]
	Address	1303	
	Function	<p>Factory-setting: the digital contact set as LOC/REM (C180) is Pushbutton based. If the PID output is the main reference and P266 Type of Keypad Page in Local Mode = Ref.Activated + Spd, allowing entering the LOCAL mode when the LOC/REM command is first sent, thus controlling the PID reference, and allowing the LOCAL mode to be maintained when the LOC/REM command is sent for the second time, thus disabling the PID and allowing setting a speed reference, the LOC/REM digital input must be set as C180a=Pushbutton.</p> <p>If C180a=2, the logic status of LOC/REM will be saved at power off and will be used when the drive is next powered on.</p>	

C181 Safety Start

C181	Range	0 ÷ 1	Inactive, Active
	Default	0	Inactive
	Level	ADVANCED	
	Address	1181	
	Function	This function enables the Safety START mode . When this function is enabled and the drive is to be restarted after resetting an alarm, open and close the ENABLE-A and ENABLE-B terminals. This prevents the drive from RUNNING when it is turned off and on again (for example after a mains loss) and the START and ENABLE-A and ENABLE-B inputs are on.	



NOTE If multiple terminal boards are selected with parameters **C140**, **C141**, **C142**, open and close the **MDI2** terminals in one of the active terminal boards to restart the drive.

C182 Multiprogramming Enable

C182	Range	0 ÷ 1	Inactive, Active
	Default	1	Inactive
	Level	ENGINEERING	
	Address	1182	
	Function	This function allows allocating two different functions to the same terminal.	



NOTE Only few preset combinations are allowed. When invalid configurations are set up, "ILLEGAL DATA" appears on the display/keypad of the Penta drive.

C183 Max. Fluxing Time Before Drive Disable

C183	Range	0 ÷ 65000	0 ÷ 65000 ms
	Default	0	Disabled
	Level	ADVANCED	
	Address	1183	
	Control	VTC and FOC	
	Function	This function disables the drive if the fluxing time period is longer than the preset time (if the ENABLE function, not a START command, is active). To restore motor fluxing, disable and enable the ENABLE function, or if with the active ENABLE function a START command is also activated.	



NOTE The time set in **C183** is added to the Fluxing Ramp Time set in **C041** / **C084** / **C127**.

C184 Fluxing at Activation only with START Closed

C184	Range	0 ÷ 1	0:No - 1:Yes
	Default	0	0:No
	Level	ADVANCED	
	Address	1184	
	Control	VTC and FOC	
	Function	Fluxing may be carried out only when the START command is closed.	

C184a Disable External Torque Limit During Fluxing

C184a	Range	0 ÷ 1	0:NO; 1:Yes
	Default	0	0:NO
	Level	ENGINEERING	
	Address	1200	
	Control	FOC	
	Function	During the fluxing stage, until the desired flux value is attained, the external torque limit (if any) set in C147 is disabled (see CONTROL METHOD MENU). During that stage, only the limits set in C047 and C048 (see LIMITS MENU) are applied. This function is useful to limit undesired motor operation—due to residual rotor magnetization—during the fluxing stage.	

C185 STOP Mode

C185	Range	0 ÷ 1	0: [Deceleration Ramp] – 1:[Free Wheel]
	Default	0	0: [Deceleration Ramp]
	Level	ADVANCED	
	Address	1185	
	Function	This function allows selecting whether the drive is to be deactivated with a controlled deceleration ramp or is left idling when the START command is open.	

C186 Fire Mode Enable Input

C186	Range	0 ÷ 16 0 ÷ 24 if ES847 or ES870 is fitted	0 → Inactive 1 ÷ 8 → MDI1 ÷ MDI8 9 ÷ 12 → MPL1 ÷ MPL4 13 ÷ 16 → TFL1 ÷ TFL4 17 ÷ 24 → XMDI1 ÷ XMDI8
	Default	0	Inactive
	Level	ENGINEERING	
	Address	1186	
	Function	This parameter allows programming a digital input to activate the Fire Mode (see the Fire Mode section).	

C187 Torque Limit Source Ref. Disable Input

C187	Range	0 ÷ 16 0 ÷ 24 if ES847 or ES870 is fitted	0 → Inactive 1 ÷ 8 → MDI1 ÷ MDI8 9 ÷ 12 → MPL1 ÷ MPL4 13 ÷ 16 → TFL1 ÷ TFL4 17 ÷ 24 → XMDI1 ÷ XMDI8
	Default	0	Inactive
	Level	ADVANCED	
	Address	1187	
	Function	This function sets a digital input allowing disabling the external torque limit. When the digital input set for C187 is active, the torque limit will depend on the parameters contained in the LIMITS MENU of the active motor.	

C187a,C187b Multitorque Inputs

C187a C187b	Range	0 ÷ 16 0 ÷ 24 if ES847 or ES870 is fitted	0 → Inactive 1 ÷ 8 → MDI1 ÷ MDI8 9 ÷ 12 → MPL1 ÷ MPL4 13 ÷ 16 → TFL1 ÷ TFL4 17 ÷ 24 → XMDI1 ÷ XMDI8
	Default	0	Inactive
	Level	ADVANCED	
	Address	1094, 1095	
	Function	This function allows generating max. 3 torque limits that can be programmed via parameters P101÷P103 . These 2 functions determine which of the 3 torque limits is active: the active value (1) or inactive value (0) of each programmed input signal determines a bit-controlled binary number, where MULTITORQUE 0 is the least significant bit (bit 0). If one of the two functions is not programmed, the relevant bit value is zero.	

Table 107: Multitorque selection

Selected Multitorque =	Bit 1	Bit 0
	MULTITORQUE 1	MULTITORQUE 0

Table 108: Selected Multitorque reference

Function:	Status of the relevant input			
MULTITORQUE 0	0	1	0	1
MULTITORQUE 1	0	0	1	1
Selected Multitorque	0	1	2	3
Resulting multitorque limit	(*)	P101	P102	P103

(*) If both Multitorque inputs are inactive, the torque limit applied is the one that would be present if no Multitorque inputs were active, such as:

- If **C147** ≠ 0, the limit coming from the source set in **C147**;
- If **C147** = 0, the limit defined by **C047**, **C048** (see LIMITS MENU).

When switching between the two Multitorque modes, the ramps defined by parameters **P026**, **P027** (see RAMPS MENU).

The activation of the input programmed in **C187** (if any) disables the torque limit forced by **C187a**, **C187** as follows:

- If both Multitorque inputs are OFF, the limit set by **C047**, **C048** is forced without applying any ramps.
- If at least one of the Multitorque inputs is ON, the limit set by **C047**, **C048** is forced by applying the ramp in **P026**.
- When the input set in **C187** is disabled, the limits set in **P101÷P103** are applied following the ramps in **P026**, **P027**.

C188a, C188b, C188c Inputs for PID MULTIREFERENCES

C188a C188b C188c	Range	0 ÷ 16 0 ÷ 24 if ES847 or ES870 is fitted	0 → Inactive 1 ÷ 8 → MDI1 ÷ MDI8 9 ÷ 12 → MPL1 ÷ MPL4 13 ÷ 16 → TFL1 ÷ TFL4 17 ÷ 24 → XMDI1 ÷ XMDI8
	Default	0	Inactive
	Level	ADVANCED	
	Address	1365, 1366, 1367	
	Function	<p>This function allows generating up to <u>7 PID references</u> that can be programmed with parameters P081a to P087a according to the operating mode selected with P080a.</p> <p>The 3 functions determine which is the active reference among the 7 available PID references: the active value (1) or the inactive value (0) of each programmed input signal determines a bit-logic value, where MULTIREF 0 is the least significant bit (bit 0) and MULTIREF 2 is the most significant bit (bit 2).</p> <p>If one of the available functions is not programmed, the value of the relevant bit is “zero”.</p>	

Table 109: Selection of PID Multireferences

Multireference selected =	Bit 2	Bit 1	Bit 0
		MULTIREFERENCE 2	MULTIREFERENCE 1

38. ENCODER/FREQUENCY INPUTS MENU

38.1. Overview

Three quick acquisition digital inputs are available in the Sinus Penta control board:

- **MDI6/ECHA/FINA;**
- **MDI7/ECHB;**
- **MDI8/FINB.**

These inputs can be used as incremental encoder reading (encoder A) or as frequency inputs.



WARNING

Digital inputs **MDI6/ECHA/FINA** and **MDI7/ECHB** are not active if ES847 or ES870 I/O expansion board is mounted: they are automatically replaced by the corresponding **XMDI6** and **XMDI7** digital inputs (see the Sinus Penta's Motor Drives Accessories - User Manual). **MDI8/FINB**, on the contrary, is always active, also with ES847 or ES870 mounted.

In addition, if **ES836** or **ES913** optional board is used (see the Sinus Penta's Motor Drives Accessories - User Manual), an additional encoder reading (encoder B) is allowed.



NOTE

If **MDI6** and **MDI7** are used for encoder reading, only Push–Pull encoders can be used.



NOTE

For the reversal of the incremental encoder speed measure, properly set up parameter **C199**.

38.1.1. WHEN ES836 IS NOT USED

• **Reading an Incremental Encoder:**

Digital inputs **MDI6** and **MDI7** are used for reading the two channels of a 24V push–pull encoder powered directly by the Sinus Penta control board (see the Sinus Penta's Installation Guide).

No function can be programmed for **MDI6** and **MDI7**; if you attempt to program **MDI6** and **MDI7**, alarm **A082** Illegal Encoder Configuration will trip when the **ENABLE** function is activated.

• **Reading a Frequency Input:**

Digital inputs **MDI6** or **MDI8** can be used.

If **MDI6** is programmed as a frequency input (**FINA**) with **C189**, no other function can be programmed; otherwise, alarm **A100** MDI6 Illegal Configuration trips when the **ENABLE** function is activated.

If **MDI8** is programmed as a frequency input (**FINB**) with **C189**, no other function can be allocated to MDI8, and **ES836** or **ES913** optional board must not be applied to the power drive, otherwise, alarm **A101** MDI8 Illegal Configuration trips when the **ENABLE** function is activated.

• **Reading a Frequency Input and an Incremental Encoder:**

MDI6 and **MDI7** are used to read the push–pull encoder, and **MDI8** is used to read the frequency input. The following alarms may trip:

- **A082** Illegal Encoder Configuration, if additional functions are allocated to **MDI6** or **MDI7**;
- **A101** MDI8 Illegal Configuration, if additional functions are allocated to **MDI8** or if the power drive detects the presence of **ES836** or **ES913** optional board.

38.1.2. WHEN USING ES836 OR ES913 OPTIONAL BOARD

- **Reading 1 or 2 Incremental Encoders:**

To read one Encoder, use ES836 optional board or digital inputs **MDI6** and **MDI7** (if a push–pull encoder is used). Both the optional board and digital inputs **MDI6** and **MDI7** can be used to read two encoders at a time. Use parameter **C189** to set the readout of the speed measure of the controlled motor or to read reference values. You can use encoder **A** or encoder **B** as a speed feedback or a reference source (speed reference, torque reference or PID reference).

Example:

If you want to use encoder **A** as a speed reference source and encoder **B** as a speed feedback, set **C189** as 6:[A Ref ; B Fbk]; use **P073** and **P074** (INPUTS FOR REFERENCES MENU) to define the min. speed and the max. speed read for scaling and saturation of encoder **A** selected as a reference source (in one of parameters **C144 ÷ C147**, CONTROL METHOD MENU); set parameter **C012** (motor 1) to [Yes] to enable the Speed Feedback from Encoder function.

If encoder A is selected, no function can be programmed for **MDI6** and **MDI7**; otherwise, alarm **A082** Illegal Encoder Configuration will trip when the **ENABLE** function is activated.

If encoder B is selected and **ES836** or **ES913** optional board is not detected by the drive, alarm **A082** Illegal Encoder Configuration will trip when the **ENABLE** function is activated.

- **Reading a Frequency Input:**

Only **MDI6** digital input (FINA) can be used as a frequency input; if **MDI8** is programmed as a frequency input (FINB) with **C189**, if the optional board is installed, alarm **A101 MDI8** Illegal Configuration trips.

No additional function must be assigned to **MDI6**; otherwise, alarm **A100 MDI6** Illegal Configuration will trip when the **ENABLE** function is activated.

- **Reading a Frequency Input and an Incremental Encoder:**

MDI6 Digital input (FINA) is used as a frequency input and Encoder B is used (because **ES836** or **ES913** board avoids reading frequency input FINB through MDI8).

If additional functions are programmed for digital input **MDI6**, alarm **A100 MDI6** Illegal Configuration will trip when **ENABLE** closes.

If alarm **A082** Illegal Encoder Configuration trips, this means that the drive has not detected **ES836** or **ES913** board (check the board wiring).

Parameter **C189** defines whether quick acquisition digital inputs are used to read a frequency input or an encoder, and if the encoder is a reference source or a feedback source.

In the **Encoder Menu**, you can also do the following:

- define the number of pls/rev for the encoder being used;
- enable or disable the speed alarm;
- define a time constant applied to read filtering;
- define whether encoders are read by means of quadrature channels or by channel A only (while the direction of rotation will be defined by channel B: ChB low level → negative rotation; ChB high level → positive rotation).

38.1.3. WHEN USING TWO ENCODERS

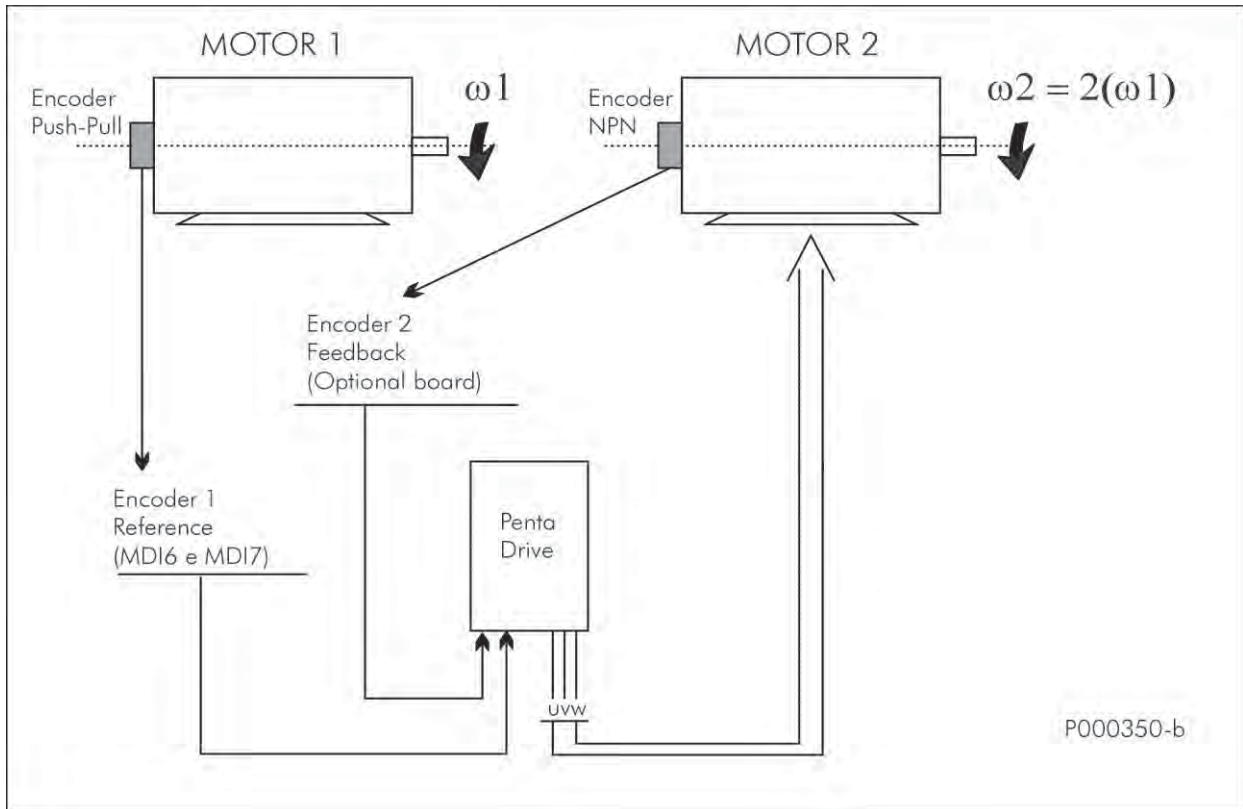

Figure 55: Using two encoders (example)

Suppose that motor 2 is to be controlled in closed chain and that its speed value is twice the speed value of motor 1. To do so, use speed of motor 1, provided with an encoder, as the reference for the Penta Drive, and use the speed measure of encoder B, which is coaxial to the motor controlled by the drive, as a speed feedback. Suppose that motor 1 speed ranges from 0 to 750rpm and that motor 1 is provided with a Push–Pull encoder with Single–Ended outputs and that its resolution is 2048 pls/rev.

Motor 2 is provided with an NPN encoder with Single–Ended outputs; its resolution is 1024 pls/rev. Only one Push–Pull encoder can be connected to digital inputs MDI6–MDI7, so encoder NPN of motor 2, representing the speed feedback of the drive, must be connected to ES836 board (drive Encoder B), whereas the encoder of motor 1 (Push–Pull), used as a reference, shall be connected to terminals MDI6 and MDI7 (drive Encoder A). Encoder Configuration is as follows:

Encoder/Frequency Inputs Menu

(operating modes and encoder feature setting)

- C189** = [6: A–Reference B–Feedback] (Encoder/Frequency input operating mode)
- C190** = 2048 pls/rev (Number of pls/rev for Encoder A)
- C191** = 1024 pls/rev (Number of pls/rev for Encoder B)
- C197** = [0: 2Ch.Quad.] (Number of channels of Encoder A)
- C198** = [0: 2Ch.Quad.] (Number of channels of Encoder B)
- C199** = [0: Fdbk.No Ref.No] (Encoder reading sign reversal)

Motor Control 1 Menu

(Setup of control mode with speed feedback from encoder and min. speed and max. speed of the controlled motor)

C012 = [Yes] (Speed feedback from M1 encoder)

C028 = 0 rpm (Min. speed of motor M1)

C029 = 1500 rpm (Max. speed of motor M1)

Control Method Menu

(Setup of the source of the speed feedback from encoder)

C143 = [8: Encoder] (Selection of reference 1 source)

C144 = [0: Disable] (Selection of reference 2 source)

C145 = [0: Disable] (Selection of reference 3 source)

C146 = [0: Disable] (Selection of reference 4 source)

References Menu

(Setup of the reading range for the encoder used as a speed reference)

P073 = 0 rpm (Encoder input min. rpm)

P074 = 750 rpm (Encoder input max. rpm)

Ramps Menu

(Ramps time applied to the reference are reset to maintain the desired speed variation without entering any delay value)

P009 = 0 (Acceleration time 1)

P010 = 0 (Deceleration time 1)

When motor 1 reaches its max. speed (750rpm), the speed reference is 100% (because the speed value read by the encoder used as a reference source is saturated and scaled with respect to the min. rpm and max. rpm set in P073, P074). Because the max. speed of the motor controlled by the drive is 1500 rpm (C029), the speed reference is 1500 rpm.

38.2. List of Parameters C189 to C199

Table 110: List of Parameters C189 to C199

Parameter	FUNCTION	User Level	MODBUS Address	DEFAULT VALUES
C189	Encoder/Frequency input operating mode	BASIC	1189	0 [Not used, Not used]
C190	Number of pls/rev for encoder A	BASIC	1190	1024
C191	Number of pls/rev for encoder B	BASIC	1191	1024
C192	Speed searching error timeout	ENGINEERING	1192	5.00 sec
C193	Error between reference and speed	ENGINEERING	1193	300 rpm
C194	Tracking error alarm enable	ENGINEERING	1194	1: Active
C195	Filter time constant over value of feedback from encoder	ENGINEERING	1195	5.0 ms
C196	Filter time constant over value of reference from encoder	ENGINEERING	1196	5.0 ms
C197	Number of channels of Encoder A	ENGINEERING	1197	0:2 Quadrature channels
C198	Number of channels of Encoder B	ENGINEERING	1198	0:2 Quadrature channels
C199	Encoder sign reversal	ENGINEERING	1199	0[Fdbk.NO;Ref.NO]

C189 Encoder/Frequency Input Operating Mode

C189	Range	0 ÷ 14	See Table 111
	Default	0	0 [Not used; Not used]
	Level	BASIC	
	Address	1189	
	Function	<p>This parameter determines the operating mode of the fast acquisition digital inputs or the encoders connected to the optional boards. If MD18 is used as a frequency input, the optional board for encoder B is not required. MD16 digital input may be used as a frequency input; if used along with MD17, it can be used for encoder A reading.</p> <p>Reading both encoders A and B can be programmed; parameter C189 defines the encoder to be used as a reference source (if set as a speed/torque reference source in the MOTOR CONFIGURATION MENU or as a PID reference source in the PID CONFIGURATION MENU) and the encoder to be used as a speed feedback.</p> <p>Configuration allowed for quick acquisition digital inputs is shown in Table 111.</p> <p>If the encoder is used as a reference source, the detected speed value will be saturated and scaled based on values set in P073 and P074 respectively (minimum and maximum value for the encoder).</p> <p><i>Example:</i> C189 [A Reference; B Unused], P073 [-1500rpm], P074 [1500rpm] if the encoder is used as a PID reference, the reference measure is expressed as a percentage of the max. value [P073 ; P074].</p> <p>If a frequency input is selected, its readout is saturated and scaled based on parameters P071 and P072 respectively (minimum and maximum value for the frequency input).</p>	

Table 111: Coding of Parameter C189

Value	When using Encoder A/FINA	When using Encoder B/FINB
0	Not used	Not used
1	EncA Feedback	Not used
2	EncA Reference	Not used
3	Not used	EncB Feedback
4	Not used	EncB Reference
5	EncA Feedback	EncB Reference
6	EncA Reference	EncB Feedback
7	EncA Reference and Feedback	Not used
8	Not used	EncB Reference and Feedback
9	MDI6 Frequency Input	Not used
10	Not used	MDI8 Frequency Input
11	MDI6 Frequency Input	EncB Reference
12	EncA Reference	MDI8 Frequency Input
13	MDI6 Frequency Input	EncB Feedback
14	EncA Feedback	MDI8 Frequency Input

Values 7-8: the same encoder can be used both as a reference source and as a reference feedback. Value 7: encoder A can be used both as a speed feedback for the motor control and as a PID regulator reference.

C190 Number of Pls/Rev for Encoder A

C190	Range	256 ÷ 10000	256 ÷ 10000 pls/rev
	Default	1024	1024
	Level	BASIC	
	Address	1190	
	Function	Defines the number of pls/rev for encoder A (encoder in the terminal board).	

C191 Number of Pls/Rev for Encoder B

C191	Range	256 ÷ 10000	256 ÷ 10000 pls/rev
	Default	1024	1024
	Level	BASIC	
	Address	1191	
	Function	Defines the number of pls/rev for encoder B (encoder that can be connected to ES836 optional board).	

C192 Timeout for Speed Alarm

C192	Range	0 ÷ 65000	0.00 ÷ 650.00 sec
	Default	500	5.00 sec
	Level	ENGINEERING	
	Address	1192	
	Function	If the speed alarm (C194) is enabled and the speed error exceeds the speed threshold (C193), this parameter determines the speed error timeout. Even if the alarm speed is disabled, time set in C192 and error threshold set in C193 are used to signal a speed searching error to digital outputs set with BRAKE or LIFT mode. Digital outputs are then disabled.	

C193 Speed Error Threshold

C193	Range	0 ÷ 32000	0 ÷ 32000 rpm
	Default	300	300 rpm
	Level	ENGINEERING	
	Address	1193	
	Function	If the speed alarm (C194) is enabled, this parameter determines the error threshold for the speed error timeout (C192).	

C194 Tracking Error Enable

C194	Range	0 ÷ 2	0: Disabled 1: Enabled 2: Active, except for when in torque limiting
	Default	1	1: Enabled
	Level	ENGINEERING	
	Address	1194	
	Function	<p>This parameter enables the tracking error alarm (A080, Tracking error).</p> <p>1: Inactive: In case of tracking error, no alarm trips. The tracking error activation is indicated by digital signal D32 (see Table 48).</p> <p>2: Active: in case of tracking error, alarm A080 trips.</p> <p>3: Active, except for when in torque limiting: same as value 2, but the “tracking error” alarm trips only if:</p> <ul style="list-style-type: none"> a) a limit source is preset in C147; b) the preset limit is <95% of the maximum torque value (parameter C048); c) the speed regulator output is in saturation mode due to the preset torque limits. <p>If the tracking error is caused by saturation of the speed regulator due to external torque limit, no alarm trips. The tracking error activation is indicated by digital signal D32 (see Table 48).</p> <p>Alarm A080 may be enabled both for FOC control with speed feedback from encoder and for VTC control.</p>	



CAUTION

If the “Tracking Error” alarm is disabled, but **C303**=Yes, the time set in **C192** and the error threshold in **C193** are implemented to manage the tracking error, that deactivates the digital outputs set in BRAKE, ABS BRAKE or ABS LIFT modes and, consequently, activates the electromechanical brake.

Vice versa, when **C303**=No, digital outputs BRAKE, ABS BRAKE or ABS LIFT are NOT deactivated.

C195 Filter Time Constant over Value of Feedback from Encoder

C195	Range	0 ÷ 30000	5 ÷ 3000.0 ms
	Default	50	5.0 ms
	Level	ENGINEERING	
	Address	1195	
	Function	This parameter defines the time constant used for filtering the reading of the encoder used as a speed feedback.	

C196 Filter Time Constant over Value of Reference from Encoder

C196	Range	0 ÷ 30000	5 ÷ 3000.0 ms
	Default	50	5.0 ms
	Level	ENGINEERING	
	Address	1196	
	Function	This parameter defines the time constant used for filtering the reading of the encoder used as a reference.	



C197 Number of Channels of Encoder A

C197	Range	0 ÷ 1	0: 2 Quadrature Channels 1: Channel only
	Default	0	0: 2 Quadrature Channels
	Level	ENGINEERING	
	Address	1197	
	Function	This parameter defines the number of channels used for encoder A reading. Factory-setting is 2 Quadrature channels. Speed can be read through one channel only (as for phonic wheel); channel 2 can define the direction of rotation (low level → negative rotation; high level → positive rotation).	

C198 Number of Channels of Encoder B

C198	Range	0 ÷ 1	0: 2 Quadrature channels 1: Channel only
	Default	0	0: 2 Quadrature channels
	Level	ENGINEERING	
	Address	1198	
	Function	This parameter defines the number of channels used for encoder B reading (see parameter C197).	

C199 Encoder Sign Reversal

C198	Range	0 ÷ 3	See Table 112
	Default	0	0 [Fdbk. NO; Ref. NO]
	Level	ENGINEERING	
	Address	1199	
	Function	This parameter permits to reverse the speed sign measured by encoder inputs.	



NOTE

When tuning the encoder, the encoder sign used as feedback is automatically adjusted to the direction of rotation of the connected motor.

Table 112: Coding of Parameter C199

Value	Feedback Encoder Sign Reversal	Reference Encoder Sign Reversal
0	Fdbk. NO	Ref. NO
1	Fdbk. YES	Ref. NO
2	Fdbk. NO	Ref. YES
3	Fdbk. YES	Ref. YES

39. BRAKING UNIT AND RAMP EXTENSION MENU

39.1. Overview

The Braking and Ramp Extension Menu enables the braking unit and sets its max. duty cycle for the drive braking resistance. If no braking resistance is installed, promptness of the DC bus voltage control can be adjusted in order to avoid OVERVOLTAGE alarm, causing abrupt deceleration. Special parameters are available, enabling controlling actions to limit DC bus voltage increase due to motor load variation.

39.1.1. BRAKING UNIT AND RAMP EXTENSION

NOTE

The braking unit is not commanded if the drive is supplied from a Regenerative source (see **C008** = xT Regen, where x can be 2, 4, 5, or 6) and the ramp extension function is disabled.

To enable the braking unit, set **C210=[With resistor]**. In this operating mode, when DC bus voltage exceeds a preset threshold value depending on the drive voltage class, the braking unit closes in the braking resistor, so energy in excess is dissipated to the resistor and DC bus voltage does not exceed voltage ratings.

The max. duty cycle of the braking resistor is parameterized with **C212** and **C211**: maximum duty cycle ($100 * T_{on} / (T_{on} + T_{off})$ [%]) and maximum time of continuous supply (T_{on}) respectively. If the braking resistor activation is $T_{on} = C212$, when this interval is over, the relevant command will be disabled for a time equal to $T_{off} = (100 - C212) * C211 / C212$ [sec].

Example:

A hoisting application featuring a Sinus Penta 0086 at 400V requires a braking resistor with a 50% duty cycle. The braking period is 30s. According to the tables in the "Braking Resistors" section (Motor Drives Accessories - User Manual) the applicable braking resistor is 10Ω – 24 kW.

The max. continuous duty for said resistor is 62s: the braking period is then compatible with that rating. Otherwise, a higher rated resistor should be applied.

Parameter setting:

C210=[With resistor].

C211=30s

C212=50%

When **C210=[With resistor]** the deceleration ramp extension is never performed, unless the braking unit has been inactive for a time longer than the time set in parameters **C211**, **C212** (weak power resistance/energy).

Factory-setting assumes that no braking resistor is provided. In this case, **C210** sets promptness, with respect to variations of DC bus, for the deceleration ramp slowing-down, in order not to overload the bus capacitor bank.

If **C210** is set to zero in FOC control, overfluxing deceleration is performed. For the other controls with **C210=0**, deceleration slows down when given values of the bus voltage are reached (depending on the drive voltage class).

If **C210** is > 0, DC bus voltage is controlled by considering the derivative of the bus voltage. The higher the value in **C210**, the lower the values for voltage variation affecting deceleration ramp times.

39.1.2. TORQUE LIMIT AND FREQUENCY INCREASE DUE TO OVERVOLTAGE – SVC (SMART VOLTAGE CONTROL)

When voltage increases due to sudden load variations, the motor operates out of the regeneration range. The mechanical energy regenerated during the negative torque transient is maintained in the drive-motor unit.

Applications

This control method may be used for applications characterized by:

- sudden variations of the load:
- Olive presses, mills,
- Rock grinders, waste grinders, etc.
- periodic work cycles also including regenerating negative torque areas:
- Pump jacks
- Eccentric loads (presses)
- Crank systems

VTC and FOC controls: a special function is available, allowing reducing the resisting torque due to DC-bus voltage increase, in order to prevent the Overvoltage alarm from tripping. A PI regulator is implemented to keep DC voltage below a preset threshold, thus limiting the maximum value of the resisting torque.

In FOC control only this function is enabled only if **C210=0**.

The regulator may be controlled in VTC control only. Parameters **C213a** and **C213b** are the regulator’s proportional gain and integral gain respectively. Parameter **C213c** sets the voltage threshold, that equals:

$$V_{th} = C213c * V_{unlock} / 100$$

where **Vunlock** depends on the drive voltage class and is typically higher than the voltage threshold activating the braking resistor.

Parameter **C213d** enables reducing the rotor flux when the regulator activates, thus further limiting the DC voltage increase.



CAUTION

The reduction of the resisting torque generated by the function above affects the speed control when the motor accelerates due to external causes. Consequently, it can happen that the motor accelerates and exceeds the maximum allowable value set in parameter **C029**.

IFD control only: parameter **C213** causes a step increase of the output frequency to limit the DC bus voltage increase due to an abrupt change (decrease) of the motor load torque.

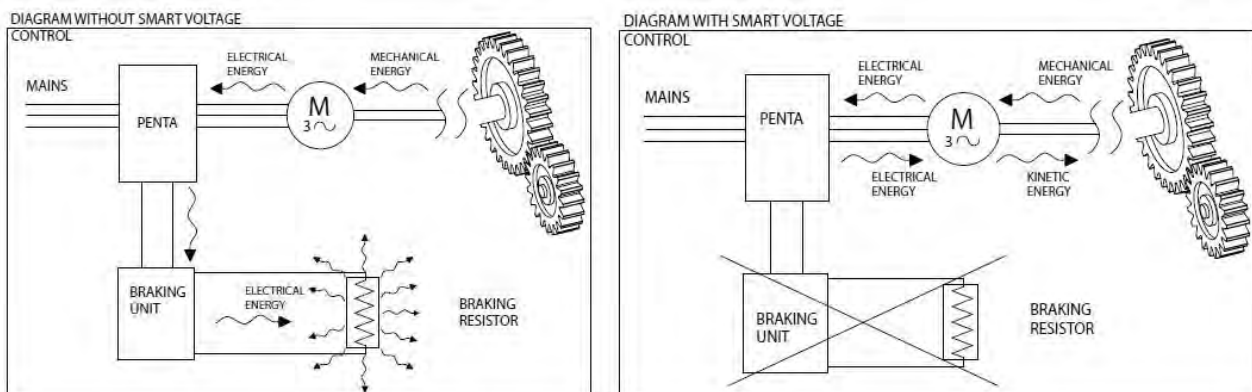

S000851

Figure 56: SVC (Smart Voltage Control)

39.2. List of Parameters C210 to C213d

Table 113: List of Parameters C210 to C213d

Parameter	FUNCTION	User Level	MODBUS Address	DEFAULT VALUES
C210	Automatic extension of down ramp	ENGINEERING	1210	See Table 82 and Table 86
C211	Max. time of continuous supply	ENGINEERING	1211	2.00sec
C212	Duty Cycle Braking (Ton/(Toff+Ton))	ENGINEERING	1212	10%
C213	Frequency Increase for Overvoltage Compensation	ENGINEERING	1279	0%
C213a	Torque Limit Proportional Gain due to Overvoltage	ENGINEERING	1251	0.020
C213b	Torque Limit Integral Gain due to Overvoltage	ENGINEERING	1252	0.010
C213c	Voltage Reference for Torque Limit	ENGINEERING	1253	100.0%
C213d	Flux Limit due to Torque Limit Activation	ENGINEERING	1254	0.0%

C210 Automatic Extension of Down Ramp

C210	Range	-1 ÷ 32000	-0.01: (With Resistance); 320.00%
	Default	See Table 82 and Table 86	
	Level	ENGINEERING	
	Address	1210	
	Function	If C210 = [With Resistor] , this parameter commands enabling resistor and DC bus relating to this operating condition, allowing dissipating energy regenerated from the motor. If no braking resistor is used, energy regenerated from the motor cannot be dissipated. In this condition, the down ramp is extended if the variation in DC bus voltage is too rapid or exceeds certain threshold values. Set a higher value in parameter C210 for a more sensitive ramp extension (a lower rating of regenerated power allows obtaining longer ramps), thus avoiding overvoltage.	

Parameter **C210** decreases the DC bus voltage threshold setting the ramp extension.

The k factor is as follows:
 $k = P_{out} / (P_{max} * 100 * C210)$,
 k ranges from 1.0 to 1.3



NOTE

The greater the k factor, the lower the DC bus level setting the ramp extension.

For example, when **C210**=0.2, power P_{out} shall exceed 5% of P_{max} in order to obtain $k > 1$.

When **C210**=2, 0.5% of P_{max} is required to obtain $k > 1$.



NOTE

Parameter **C210** is interlocked with parameter **P031** (Gradient variation acceleration reset) so that **C210** ≠ **-0.01:With resistance** cannot be programmed in conjunction with **P031** = 0:No.

C211 Max. Time of Continuous Supply for Braking Resistance

C211	Range	0 ÷ 32000	0 ; 320.00 sec
	Default	200	2.00 sec
	Level	ENGINEERING	
	Address	1211	
	Function	This parameter determines the max. continuous operating time required for the braking resistance. If the braking resistance is used for a time C211 without being deactivated, the braking resistance command is automatically disabled for a time of inactivity set in C212 .	

C212 Duty Cycle Braking (Ton/(Toff+Ton))

C212	Range	0 ÷ 100	0 ÷ 100%
	Default	10	10%
	Level	ENGINEERING	
	Address	1212	
	Function	$C212 = (Ton/(Ton+Toff))*100$ This parameter determines the operating duty cycle allowed for the braking resistance. It is expressed as a percentage and defines the time of inactivity of the braking resistance when it is continuously operating for the max. time set in C211 .	

C213 Frequency Increase for Overvoltage Compensation – Smart Voltage Control SVC (Smart Voltage Control)

C213	Range	0 ÷ 1000	0 ÷ 0.1000
	Default	0	0.0000
	Level	ENGINEERING	
	Address	1279	
	Control	IFD	
	Function	If this parameter is set > 0, a value given by C213 * derivative_voltage_DC (expressed in V/s) is summed up to the frequency currently set for the motor. In that way, when DC voltage abruptly changes due to sudden variations of the load torque, the output frequency is promptly adjusted to compensate for voltage increase and avoid overvoltage conditions. A value equal to 0.0200 ensures optimum operation in most applications; however, the optimum value for this parameter is to be found by trial and error. Example: Suppose that the DC-bus voltage increases by 3 V in 1 ms, such as 3000 V/s. If C213 is worth 0.02, the following will be instantly summed up to the present output frequency: $3000 * 0.02 / 60 * 2 = 2 \text{ Hz}$ for a motor with 2 pole pairs. This amount, however, is limited to 5% of the present output frequency. As per the example above, if f _{out} = 30 Hz, the amount value would be limited to 30 * 0.05 = 1.5 Hz.	



NOTE Parameter **C213** has no effect if **C210** = [With Resistance].

C213a Torque Decrease Proportional Gain due to Overvoltage

C213a	Range	0 ÷ 32000	0.000 ÷ 32.000
	Default	20	0.020
	Level	ENGINEERING	
	Address	1251	
	Control	VTC	
	Function	This function is available only when the VTC control is activated. This is the proportional gain of the DC-bus voltage regulator adjusting the resisting torque limit when voltage exceeds the value set in parameter C213c .	

C213b Torque Decrease Integral Gain due to Overvoltage

C213b	Range	0 ÷ 32000	0.000 ÷ 32.000
	Default	10	0.010
	Level	ENGINEERING	
	Address	1252	
	Control	VTC	
	Function	This function is available only when the VTC control is activated. This is the integral gain of the DC-bus voltage regulator adjusting the resisting torque limit when voltage exceeds the value set in parameter C213c .	

C213c Voltage Reference for Torque Decrease

C213c	Range	0 ÷ 1200	0.0 ÷ 120.0%
	Default	1000	100.0%
	Level	ENGINEERING	
	Address	1253	
	Control	VTC	
	Function	This function is available only when the VTC control is activated. It sets the reference value for the regulator DC voltage adjusting the resisting torque limit. The limiting function activates when voltage exceeds the value below: $V_{th} = C213c * V_{unlock} / 100$ where V_{unlock} is based on the inverter voltage class and is typically higher than the trip voltage of the braking resistor. The default value ensures that the braking resistor trips before the torque limit function is activated. If the braking resistor is not fitted, it may be useful to set a lower value for this parameter to ensure prompt activation of the torque limit.	

C213d Flux Limit due to Torque Decrease Activation

C213d	Range	0 ÷ 1000	0.0 ÷ 100.0%
	Default	0	0.0%
	Level	ENGINEERING	
	Address	1254	
	Control	VTC	
	Function	This function is available only when the VTC control is activated. If the torque limit is adjusted by the DC bus voltage regulator, the rotor flux is decreased by the same value of the torque limit multiplied by the value of this parameter. Example: If the regulator generates a 50% instant torque limit and C213d is worth 30%, the flux will be decreased by $50 * 30 / (100 * 100) = 15\%$, and will be increased to 85% of the value that should be adopted under normal operating conditions. This parameter keeps DC voltage low when the motor acceleration due to external causes continues over time. Low parameter values (< 50%) may cause uncontrolled rotation of the motor.	

40. DC BRAKING MENU

40.1. Overview

When the IFD or VTC control algorithm are used, DC current can be injected into the motor to stop it. DC current may be automatically injected at stop and/or at start; DC current injection may also be controlled by the terminal board. All relevant parameters are included in the DC BRAKING MENU. The intensity of the DC current injected is expressed as a percentage of the rated current of the active motor.

40.1.1. DC BRAKING AT START AND NON-CONDENSING FUNCTION

To activate DC braking at start, set **C216** to [YES]. Braking occurs after sending a **START** command, with a speed reference other than zero, before the acceleration ramp. A **START** command may be one of the following: **RUN** command or **REV** command sent via terminal board; **START** command from keypad, etc., depending on the preset control mode. DC braking level and duration are set in the following parameters:

C220 Expressed as a percentage of the rated current of the controlled motor.

C218 Expressed in seconds.

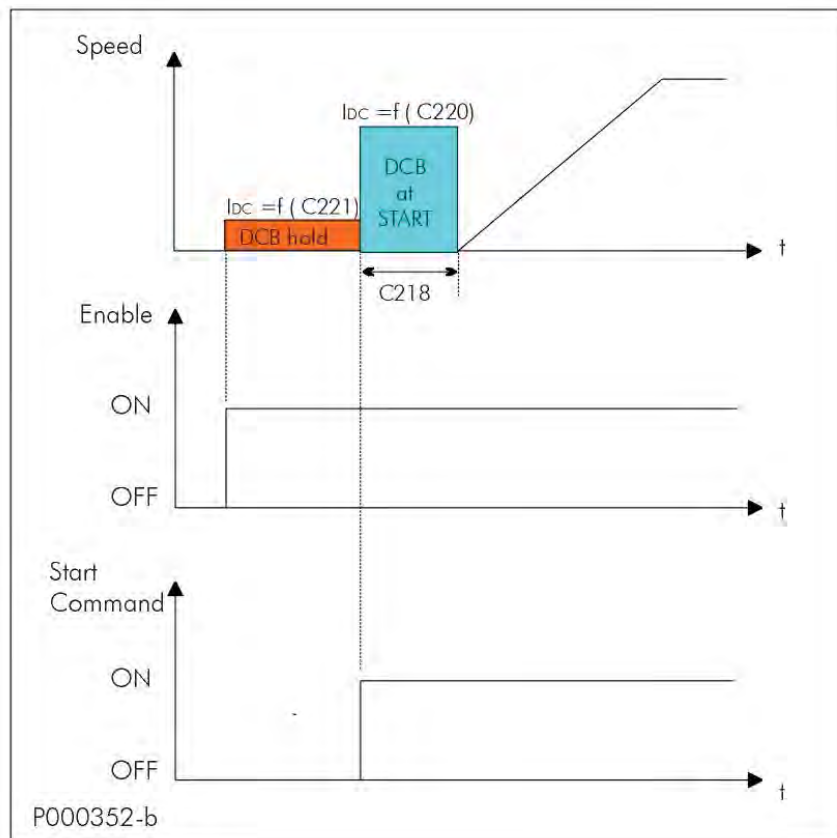

Figure 57: DCB Hold and DCB at Start

Output speed, holding and DC braking current when the DCB Hold and DCB at Start functions are active.

The non-condensing function consists in injecting DC into the motor. DC current brakes the motor and heats the motor windings, thus avoiding condensation. This function is active only for the IFD control if **C221** is other than zero and the **ENABLE** function is activated. For the other control algorithms, the non-condensing function is performed by injecting current during motor fluxing. Parameter **C221**, expressed as a percentage of the rated current of the controlled motor, determines the level of direct current injected into the motor.

Parameters used to program this function are the following:

- C216 enabling DCB at Start;**
- C218 setting the duration of DCB at Start;**
- C220 setting the intensity of the DC braking;**
- C221 setting the intensity of the holding current (this function is active for the IFD control only).**

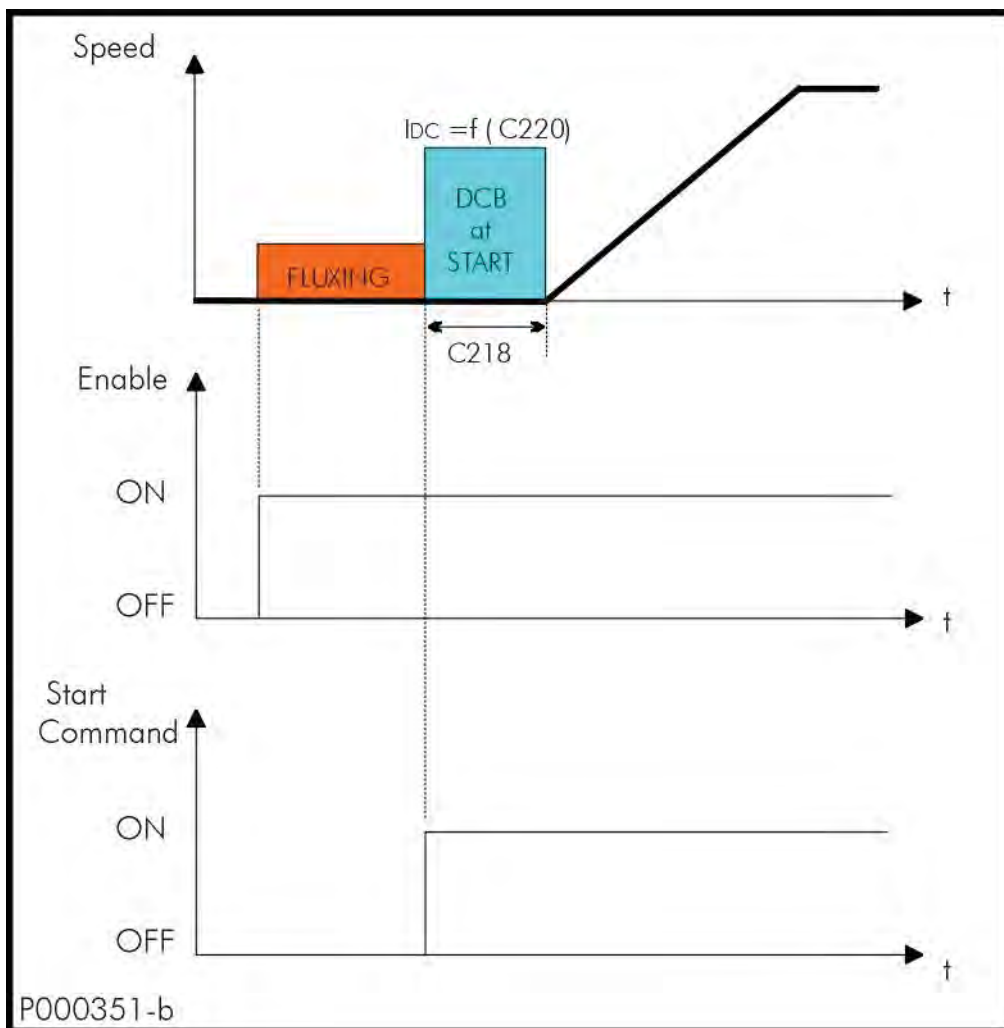

Figure 58: DCB at Start with VTC Control

Output Speed and DC Braking when the DCB At Start Function is active for the Vector Torque control.

40.1.2. DC BRAKING AT STOP

To activate this function, set **C215** to [YES] or, in Power Down mode, set **C234** (Power Down Stop Mode) as DCB. DC Braking occurs after sending a “stop with ramp” command. The speed level for DC Braking is set in **C219**. If the drive is in Power Down mode and **C234** is set as DCB, the speed level is set in **C235** (Power Down Stop Level). The figure below illustrates the output speed and DC Braking trends when the DC Braking at Stop function is active.

Parameters used to program this function are the following:

- C215** function enabling;
 - C217** braking duration;
 - C219** motor speed at the beginning of DC Braking;
 - C220** intensity of DC braking.
- In Power Down mode, if **C234** (Power Down Stop Mode) is set as DCB:
C235 motor speed at the beginning of DC Braking.

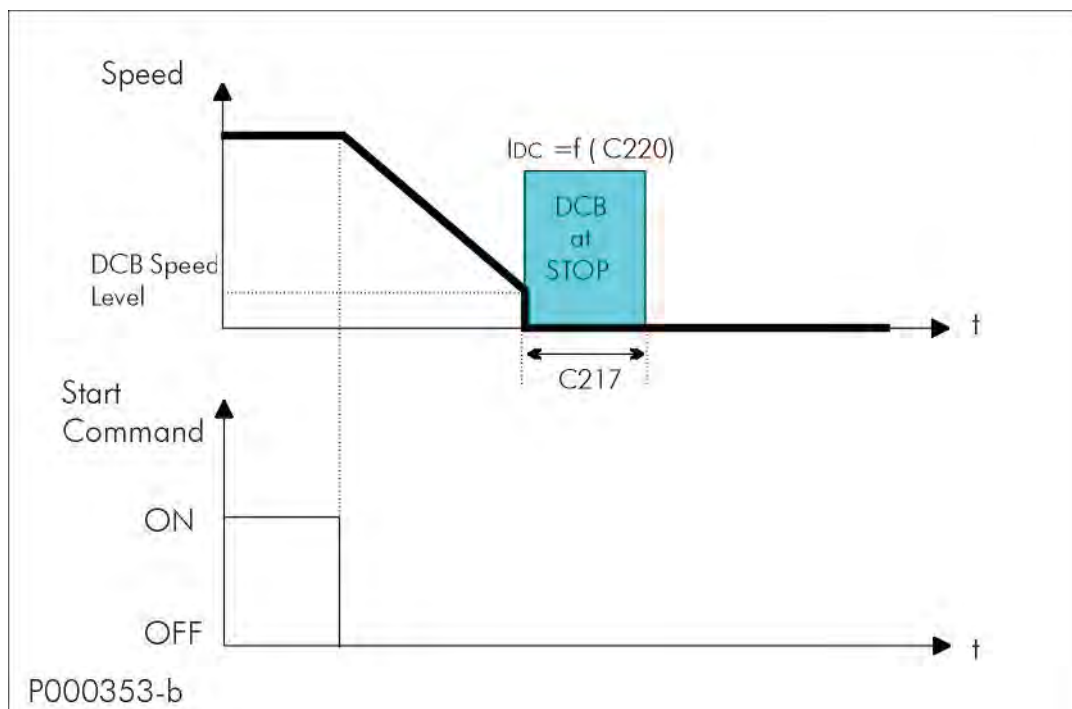

Figure 59: DCB at Stop

Motor speed and DC Braking patterns when the DC BRAKING AT STOP function is active.

40.1.3. DC BRAKING COMMAND SENT FROM DIGITAL INPUT

Activate the digital input set as DCB (**C160**) to send a DC Braking command. DC Braking duration is determined by the following formula:

$$t^* = C217 * (n_{OUT} / C219) \text{ with } n_{OUT} / C219 \text{ equal to max. } 10.$$



NOTE DC braking sent from digital input operates when the drive is stopped in IFD and VTC controls. Also, Power Down mode must be disabled (**C225 = 0**).

Possible cases:

- a) $t1 > t^*$ time t1 for braking command is longer than t*.

To restart the motor following the preset acceleration ramp when DC Braking is over, just disable the DCB command and disable and enable again the **START** command (see figure below).

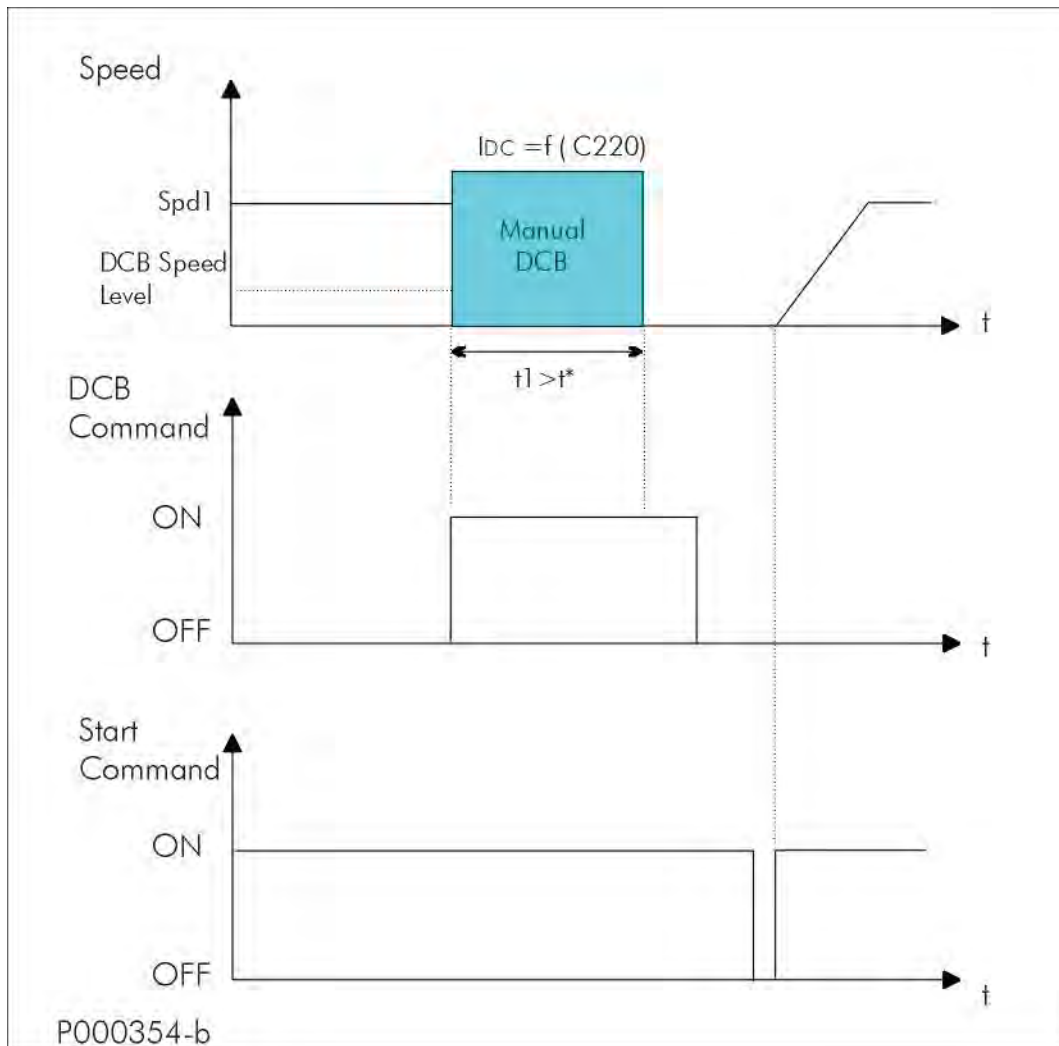

Figure 60: Manual DCB (Example 1)

Motor Speed, DC Braking, Manual DCB Command and START Command if $t1 > t^*$.

b) $t1 < t^*$ time $t1$ for braking command is shorter than t^* .
Two different cases may occur, depending on the control algorithm and the setup of the motor speed searching function.

Speed Searching function disabled (C245 [NO])

Prematurely disable the manual braking command to stop DC braking. If the motor is still rotating, it will start idling. To restart the motor following the preset acceleration ramp, simply disable and enable the **START** command (see Figure 61).

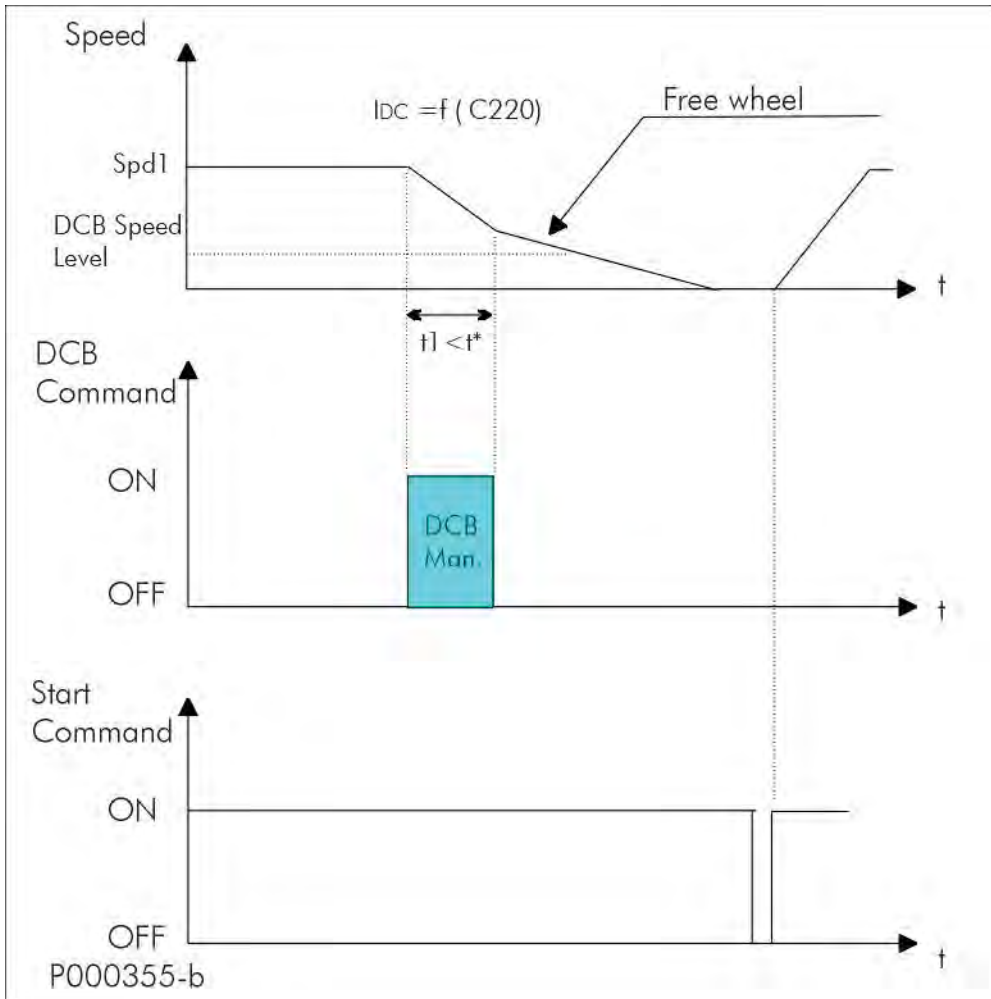

Figure 61: Manual DCB (Example 2)

Motor Speed, DC Braking, Manual DCB Command and START Command if $t1 < t^*$ and the Speed Searching Function is disabled.

Speed Searching function enabled (C245 [YES])

Prematurely disable the manual braking command to activate the Speed Searching function. When the motor speed searching occurs, the motor speed is increased depending on the preset acceleration ramp (see Figure 62).

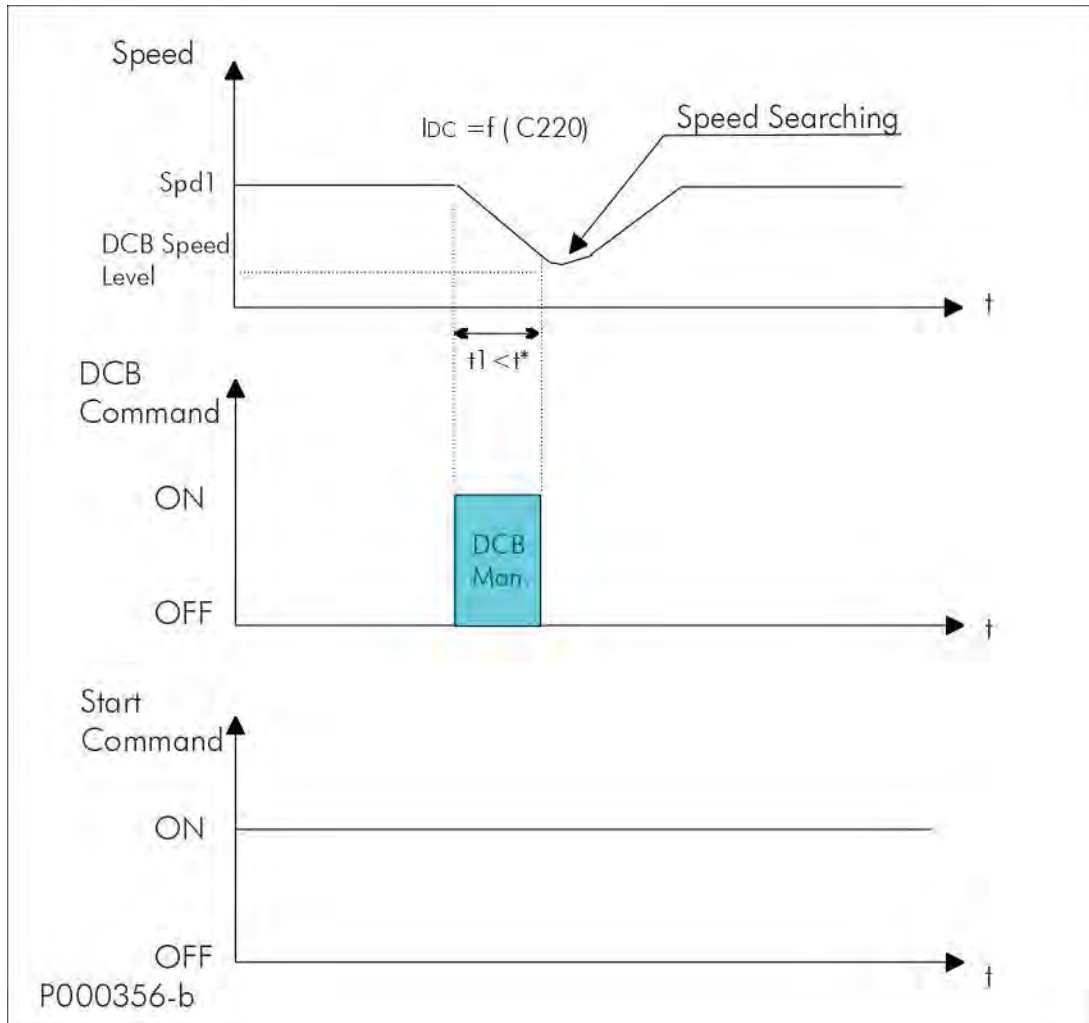

Figure 62: Manual DCB (Example 3)

Motor Speed, DC Braking and Manual DCB Command and START Command if $t1 < t^*$, the control algorithm is IFD and the Speed Searching Function is enabled.

40.2. List of Parameters C215 to C224

Table 114: List of Parameters C215 to C224

Parameter	FUNCTION	User Level	MODBUS Address	Default Values
C215	Enabling DCB at Stop Function	ADVANCED	1215	0:NO
C216	Enabling DCB at Start Function	ADVANCED	1216	0:NO
C217	DCB at Stop Duration	ADVANCED	1217	0.5
C218	DCB at Start Duration	ADVANCED	1218	0.5
C219	Speed at the Beginning of DCB at Stop	ADVANCED	1219	50rpm
C219a	VTC Speed Ramp Duration	ENGINEERING	1213	500 ms
C220	DCB Current Level	ADVANCED	1220	100%
C220a	VTC Current Filter Time Constant	ENGINEERING	1214	300 ms
C220b	Proportional Gain of the VTC Current Controller	ENGINEERING	1236	20
C220c	Integral Time Constant of the VTC Current Regulator	ENGINEERING	1237	100 ms
C221	DCB Hold	ADVANCED	1221	0%
C222	Ramp Braking Time for Motor 1 DCB	ENGINEERING	1222	See Table 82 and Table 86
C223	Ramp Braking Time for Motor 2 DCB	ENGINEERING	1223	
C224	Ramp Braking Time for Motor 3 DCB	ENGINEERING	1224	

C215 Enabling DCB at Stop Function

C215	Range	0 ÷ 1	0: No; 1: Yes
	Default	0	0: No
	Level	ADVANCED	
	Address	1215	
	Control	IFD and VTC	
	Function	Enables DC Braking during deceleration when the speed set in C219 is reached (or the speed set in C235 if in Power Down mode and C234 [DCB] is reached).	

C216 Enabling DCB at Start Function

C216	Range	0 ÷ 1	0: No; : Yes
	Default	0	0: No
	Level	ADVANCED	
	Address	1216	
	Control	IFD and VTC	
	Function	Enables the DC Braking at Start function.	

C217 DCB at Stop Duration

C217	Range	1 ÷ 600	0.1; 60.0 sec.
	Default	5	0.5 sec
	Level	ADVANCED	
	Address	1217	
	Control	IFD and VTC	
	Function	Determines the duration of the DCB at Stop function (C215 =1:Yes or C160 enabled).	

C218 DCB at Start Duration

C218	Range	1 ÷ 600	0.1 ÷ 60.0 sec.
	Default	5	0.5 sec
	Level	ADVANCED	
	Address	1218	
	Control	IFD and VTC	
	Function	Determines the duration of the DCB at Start function.	

C219 Speed at the Beginning of DCB at Stop

C219	Range	0; 1000	0; 1000 rpm
	Default	50	50rpm
	Level	ADVANCED	
	Address	1219	
	Control	IFD and VTC	
	Function	Determines the speed at the beginning of DCB at stop while decelerating (C215 =1:Yes or C160 enabled).	

C219a VTC Speed Ramp Duration

C219a	Range	1 ÷ 32000	1 ÷ 32000 ms
	Default	500	500 ms
	Level	ENGINEERING	
	Address	1213	
	Control	VTC	
	Function	Ramp duration to zero speed before activating DC Brake in case of manual request by digital input (VTC control).	

C220 DCB Current Level

C220	Range	0 ÷ MIN [(I _{peak inverter} /I _{mot})*100 ; 120]	0% ÷ Min[I _{peak inverter} /I _{mot} , 120%]
	Default	100	100%
	Level	ADVANCED	
	Address	1220	
	Control	IFD and VTC	
	Function	Determines the level of direct current injected to brake the motor. It is expressed as a percentage of the rated current of the controlled motor.	

C220a VTC Current Filter Time Constant

C220a	Range	0 ÷ 32000	0 ÷ 32000 ms
	Default	300	300 ms
	Level	ENGINEERING	
	Address	1214	
	Control	VTC	
	Function	Filter time constant for a smooth change between actual currents and DC Brake currents (id=i _{_DCB} , iq=0) when the VTC control algorithm is activated.	

C220b Proportional Gain of the VTC Current Controller

C220b	Range	0 ÷ 32000	0 ÷ 32000
	Default	20	20
	Level	ENGINEERING	
	Address	1236	
	Control	VTC	
	Function	Current proportional gain during DC Braking when the VTC control algorithm is activated.	

C220c Integral Time Constant of the VTC Current Regulator

C220c	Range	1 ÷ 32000	1 ÷ 32000 ms [Disabled]
	Default	100	100 ms
	Level	ENGINEERING	
	Address	1237	
	Control	VTC	
	Function	Current integral time constant during DC Braking when the VTC control algorithm is activated.	

C221 DCB Hold

C221	Range	0 ÷ 100	0; 100%
	Default	0	0%
	Level	ADVANCED	
	Address	1221	
	Control	IFD	
	Function	Determines the level of direct current injected during the Hold function. To activate this function, set a value other than zero in parameter C221 . DC level is expressed as a percentage of the rated current of the controlled motor.	

C222 (C223, C224) Ramp Braking Time for DCB

C222 (Motor 1) C223 (Motor 2) C224 (Motor 3)	Range	2 ÷ 32000	2 ÷ 32000 msec
	Default	See Table 82 and Table 86	
	Level	ENGINEERING	
	Address	1222, 1223, 1224	
	Control	IFD and VTC	
	Function	This parameter represents the time required for field weakening before DCB.	

41. POWER DOWN MENU

41.1. Overview

In the case of power failure, the drive can be kept powered on by exploiting the kinetic energy of the motor and the load: energy recovered due to motor slowing down is used to power the drive, thus avoiding losing the drive control when a black-out occurs.

All parameters relating to the Power Down function are included in the Power Down submenu in the Configuration menu.

The following options are available (parameter **C225**):

- **[NO]**: The function is disabled.
- **[YES]**: After the time set in **C226** (Power Down start delay), starting from the instant when power down occurs, a deceleration ramp takes place (deceleration ramp in Power Down **C227**). The time period of the deceleration ramp can be user-defined.
- **[YES V]**: In case of power down for a time longer than **C226**, the motor coasts to stop, so that DC bus voltage value is kept constant at **C230**. To do so, a PI (proportional-integral) regulator is used, which is adjusted through parameter **C231** (proportional term) and **C232** (integral term).
- **[Alarm]**: In case of power down, when the time set in **C226** is over, alarm **A064** trips (factory setting).



NOTE

If the mains loss deactivates the **ENABLE-A** and **ENABLE-B** commands, the motor cannot coast to stop, because these commands are required for the hardware enable of IGBTs.



NOTE

If a drive is DC-powered by a Regenerative Penta (or an equivalent drive stabilizing DC bus voltage), Power Down cannot occur (**C008** = xT Regen, where x can be 2, 4, 5, or 6).

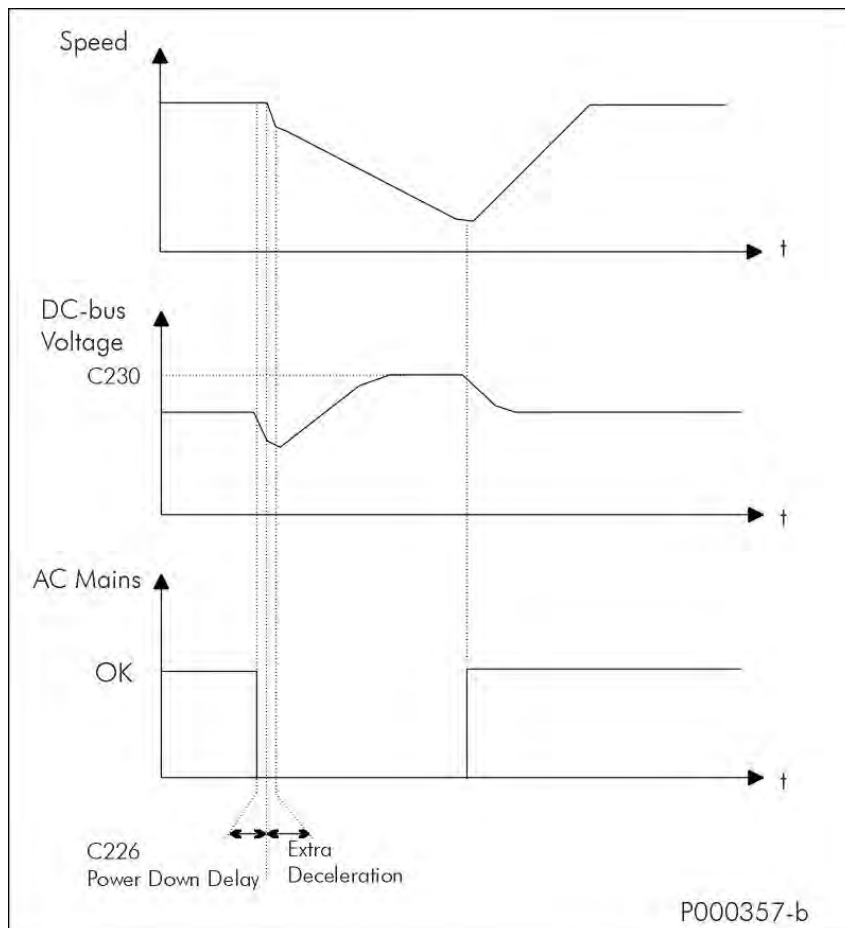



Figure 63: Power Down (Example)

The figure above illustrates the patterns of the motor speed and the DC bus voltage in case of mains loss. In the example above, power supply is restored before the drive turns off and before the deceleration ramp is over, so the motor accelerates with the preset acceleration ramp.

If power supply is restored during the deceleration ramp in Power Down, the connected motor accelerates following the selected acceleration ramp. A speed value for the end of Power Down can be set in **C235**; the desired operating mode at stop can be set in **C234**.

When the motor speed attains the end level of Power Down, the following functions can be selected in parameter **C234**:

– **[Stop]**: The drive will control the motor until it stops down, independently of the value set in **C235**.

When the motor stops and power supply is restored, the RUN command must be disabled and enabled again to accelerate the motor. Warning **W28 OPEN START** is displayed.

– **[DCB]**: When the speed of the Power Down end set in **C235** is attained, DC braking occurs.

If power supply is restored during DC braking, the RUN command must be disabled and enabled again to accelerate the motor. Warning **W28 OPEN START** is displayed.

– **[Stand-By]**: When the speed of the Power Down end set in **C235** is attained, the drive is in stand-by.

If power supply is restored when the drive is on stand-by, the RUN command must be disabled and enabled again to accelerate the motor. Warning **W28 OPEN START** is displayed.

41.2. List of Parameters C225 to C235

Table 115: List of Parameters C225 to C235

Parameter	FUNCTION	Access Level	MODBUS Address	Default Values
C225	Procedure in case of Power Down	ENGINEERING	1225	3:Alarm
C226	Power Down enable delay	ENGINEERING	1226	10 ms
C227	Stop ramp time in Power Down	ENGINEERING	1227	20 sec
C228	Start increment of ramp gradient in P.D.	ENGINEERING	1228	0.10%
C229	Improved sensitivity of DC bus control	ENGINEERING	1229	1
C230	Voltage level of DC bus in Power Down	ENGINEERING	1230	339V for class 2T 679V for class 4T(380;480V) 707V for class 4T(481;500V) 813V for class 5T 976V for class 6T
C231	PI Proportional constant for automatic deceleration	ENGINEERING	1231	0.050
C232	PI Integral time for automatic deceleration	ENGINEERING	1232	0.5 sec
C234	Ramp action at the end of Power Down	ENGINEERING	1234	0: Stop
C235	Motor speed at the end of Power Down	ENGINEERING	1235	0 rpm

C225 Procedure in Case of Power Down

C225	Range	0 ÷ 3	0: Disabled 1: Yes 2: YesV 3: Alarm
	Default	3	3: Alarm
	Level	ENGINEERING	
	Address	1225	
	Function	Type of power down: 0: Disabled The Power Down function is disabled. 1: Yes In case of mains loss after a time longer than the time set in C226 starting from the mains loss detection, the deceleration ramp set in C227 is performed. 2: YesV In case of mains loss, deceleration is automatically regulated by a PI regulator (see C231 and C232), so that voltage level in DC link is kept constant at the reference value set in C230 . IFD control: because no torque demand regulation is available, the deceleration ramp gradient is adjusted depending on the gradient value set in C227 . 3: Alarm In case of power failure, the A064 Mains Loss alarm trips after the time set in C226 .	



NOTE

If a drive is DC-powered by a Regenerative Penta (or an equivalent drive stabilizing DC bus voltage), Power Down cannot occur (**C008** = xT Regen, where x can be 2, 4, 5, or 6).

C226 Power Down Enable Delay

C226	Range	1 ÷ 250	1 ÷ 250 ms
	Default	10	10 ms
	Level	ENGINEERING	
	Address	1226	
	Function	This parameter determines the Power Down delay after a mains loss is detected by the drive. If C225 = Alarm, this delay is applied to the alarm tripped.	

**NOTE**

Setting a too long Power Down delay in case of mains loss can cause the drive to switch off.

C227 Stop Ramp Time in Power Down

C227	Range	1 ÷ 32000	1 ÷ 32000 sec
	Default	20	20 sec
	Level	ENGINEERING	
	Address	1227	
	Function	Determines the gradient of the deceleration ramp occurring at Power Down (after the first extra deceleration stage) if C225 = Yes. IFD Control algorithm: C227 is the basic gradient for deceleration adjustment when C225 = Yes V.	

C228 Start Increment of Ramp Gradient in Power Down

C228	Range	-100 ÷ 10000	-1.00 ÷ + 100.00 %
	Default	10	0.10%
	Level	ENGINEERING	
	Address	1228	
	Function	Determines an increase in deceleration ramp gradient at the beginning of the Power Down function. This is required to increase DC bus voltage. C228 = 0% start deceleration is due to C227 (C228 has no effect) C228 = 100% start deceleration is 100 times faster than deceleration set in C227 (start ramp = C227/100 sec) C228 = -1.00% start deceleration is zero (deceleration ramp of infinite time)	

C229 Improved Sensitivity of DC Bus Control

C229	Range	1 ÷ 250	1 ÷ 250
	Default	1	1
	Level	ENGINEERING	
	Address	1229	
	Function	Based on the DC bus voltage trend, this function allows detecting mains loss in advance. If the value for this coefficient is too high, erroneous mains loss conditions can be detected, due to a sudden drop in DC bus voltage.	

C230 Voltage Level of DC Bus in Power Down

C230	Range	250 ÷ 450 for Class 2T 400 ÷ 800 for Class 4T 500 ÷ 960 for Class 5T 600 ÷ 1150 for Class 6T	250 ÷ 450 V for Class 2T 400 ÷ 800 V for Class 4T 500 ÷ 960 V for Class 5T 600 ÷ 1150 V for Class 6T
	Default	339 for Class 2T 679 for Class 4T (380÷ 480V) 707 for Class 4T (481÷ 500V) 813 for Class 5T 976 for Class 6T	339 V for Class 2T 679 V for Class 4T (380÷ 480V) 707 V for Class 4T (481÷ 500V) 813 V for Class 5T 976 V for Class 6T
	Level	ENGINEERING	
	Address	1230	
	Function	Determines the reference value for DC bus voltage in case of automatic deceleration in Power Down; C225 = Yes V.	

C231 PI Proportional Constant for Automatic Deceleration

C231	Range	0 ÷ 32000	0.000 ÷ 32.000
	Default	50	0.050
	Level	ENGINEERING	
	Address	1231	
	Function	Proportional coefficient used in PI regulator controlling automatic deceleration in case of Power Down; C225 =Yes V.	

C232 PI Integral Time for Automatic Deceleration

C232	Range	1 ÷ 32000	0.001 ÷ 31.999 sec 32000 = Disabled
	Default	500	0.5 sec
	Level	ENGINEERING	
	Address	1232	
	Function	Integral time used in PI regulator controlling automatic deceleration in case of Power Down; C225 =Yes V.	

C234 Ramp Action at the End of Power Down

C234	Range	0 ÷ 2	0: Stop 1: Stand-by 2: Dcb
	Default	0	0: Stop
	Level	ENGINEERING	
	Address	1234	
	Function	<p>When the motor speed during Power Down attains the Power Down end value set in C235, three operating modes are possible depending on C234 programming:</p> <p>[Stop] If the drive is capable of bearing DC bus voltage, it will control the motor until it stops irrespective of the speed value set in C235. If power supply is restored when the deceleration ramp is over, the RUN command must be disabled and enabled again to accelerate the motor. If power supply is restored when the motor is still decelerating, the speed of reference is forced to the motor with the preset acceleration ramp.</p> <p>[Stand-by] When decelerating, once the speed value set in C235 is attained, the drive is put on stand-by and the motor keeps decelerating (motor idling). If power supply is restored, the same conditions as described in the step above (see [Stop]); instead of stopping the motor, the drive is put on stand-by.</p> <p>[DCB] When decelerating, once the speed value set in C235 is attained, DC braking occurs. Its duration depends on the speed value set in C235 and on DC braking parameters (see the DC BRAKING MENU): $t^* = C217 * (C235 / C219)$ with C235/C219 equal to max. 10. If power supply is restored, the same conditions as described in the step above occur (see [Stop]); instead of stopping the motor, the drive performs DC braking.</p>	

C235 Motor Speed at the End of Power Down

C235	Range	0 ÷ 5000	0 ÷ 5000 rpm
	Default	0	0 rpm
	Level	ENGINEERING	
	Address	1235	
	Function	<p>Motor speed at the end of Power Down. If C234 is set as [Stand-by], the drive is put on stand-by; if C234 is set as [DCB], it determines DC braking. Both conditions occur during the deceleration ramp due to Power Down and when the speed value set in C235 is attained.</p>	

42. SPEED SEARCHING MENU

42.1. Overview

When a command is sent to disable the drive, the motor idles. When the drive activates again, the Speed Searching function allows the drive to reach the motor speed.

All parameters relating to this function are included in the Speed Searching submenu in the Configuration menu.

For FOC control, the motor speed of rotation is always known, so this function is always active and independent of the parameters of the relevant menu.



NOTE The Speed Searching parameters are used for IFD and VTC control algorithm.

When **C245** is set to [YES], do the following to activate the Speed Searching function:

- deactivate and reactivate the **ENABLE** function before t_{SSdis} is over (**C246**);
- if **C185** = 1:[Free wheel], open and close the START command before t_{SSdis} (**C246**) is over;
- disable the DC Braking command before the DC braking preset time is over (see the DC BRAKING MENU);
- reset any alarm tripped (with reference other than 0) before t_{SSdis} is over.

If **C250** ≠ 0 [**Disable**], the Speed Searching function activates only if the programmed input is active.

Speed searching does not take place when the drive turns off due to mains loss.

If the drive restarts after a time longer than t_{SSdis} (**C246**), frequency output is generated following the acceleration ramp, and no speed searching takes place.

If **C246** 0: (**Always On**), speed searching (if enabled with **C245**) occurs when the drive restarts (RUN), irrespective of the time elapsed from disabling.

The figures below show output frequency and motor rpm during speed searching.

After time t_0 for rotor demagnetization, speed searching occurs as follows (see 3 steps below):

Speed at the beginning of the speed searching function depends on the settings in C249.

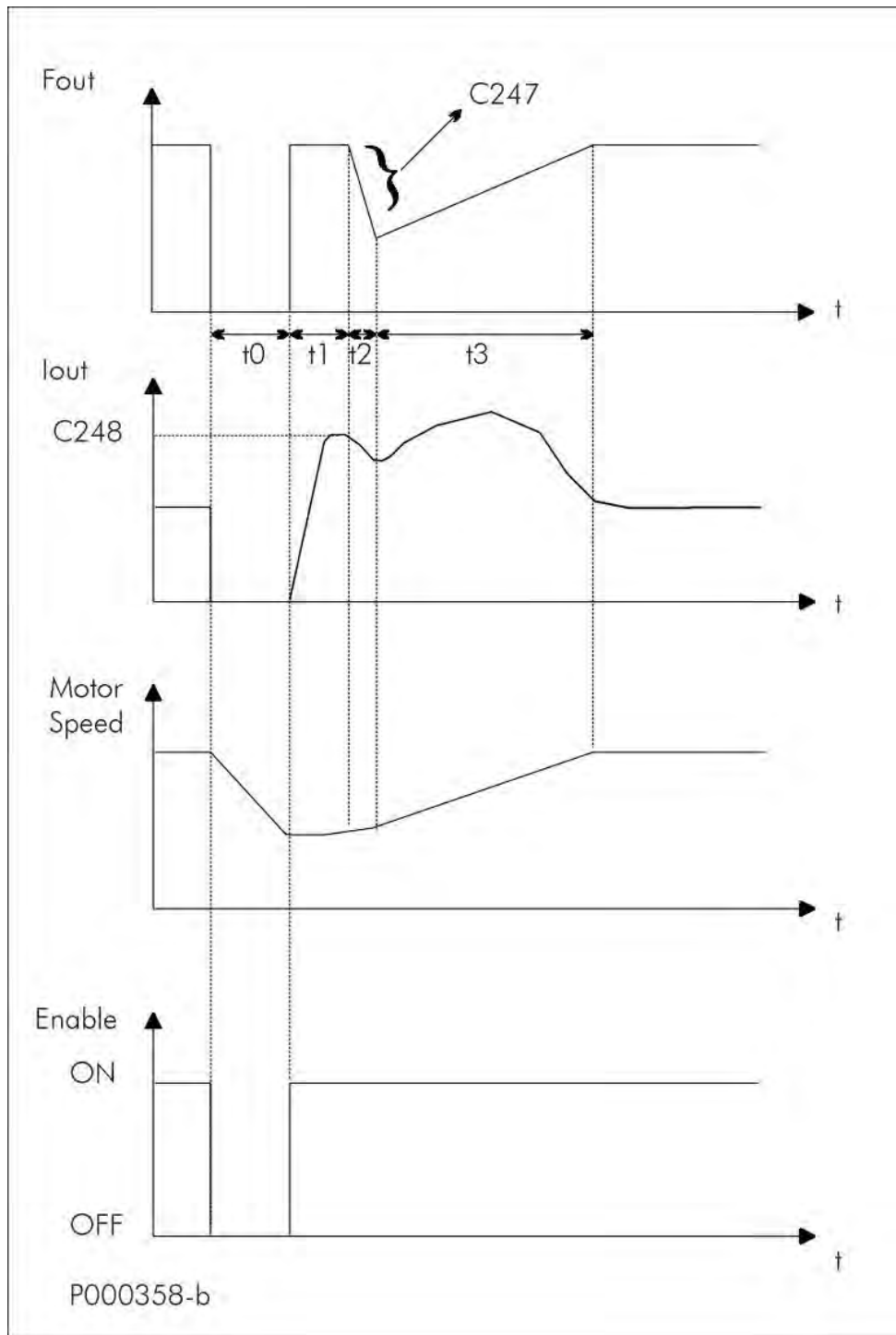

Figure 64: Speed Searching (Example 1)

– Output Frequency and motor RPM for the Speed Searching Function (**C245** = [YES]) activated by the **ENABLE-A** and **ENABLE-B** command. $t_0 < t_{SSdis}$ (**C246**) or **C246** = 0.

Three stages:

Time t_1 The drive output frequency corresponds to the last value which was active before disabling the drive; output current matches with the value set in **C248**;

Time t₂ Output frequency is decremented following the ramp set in **C247** for rotation speed searching;
Time t₃ The connected motor accelerates following the acceleration ramp.

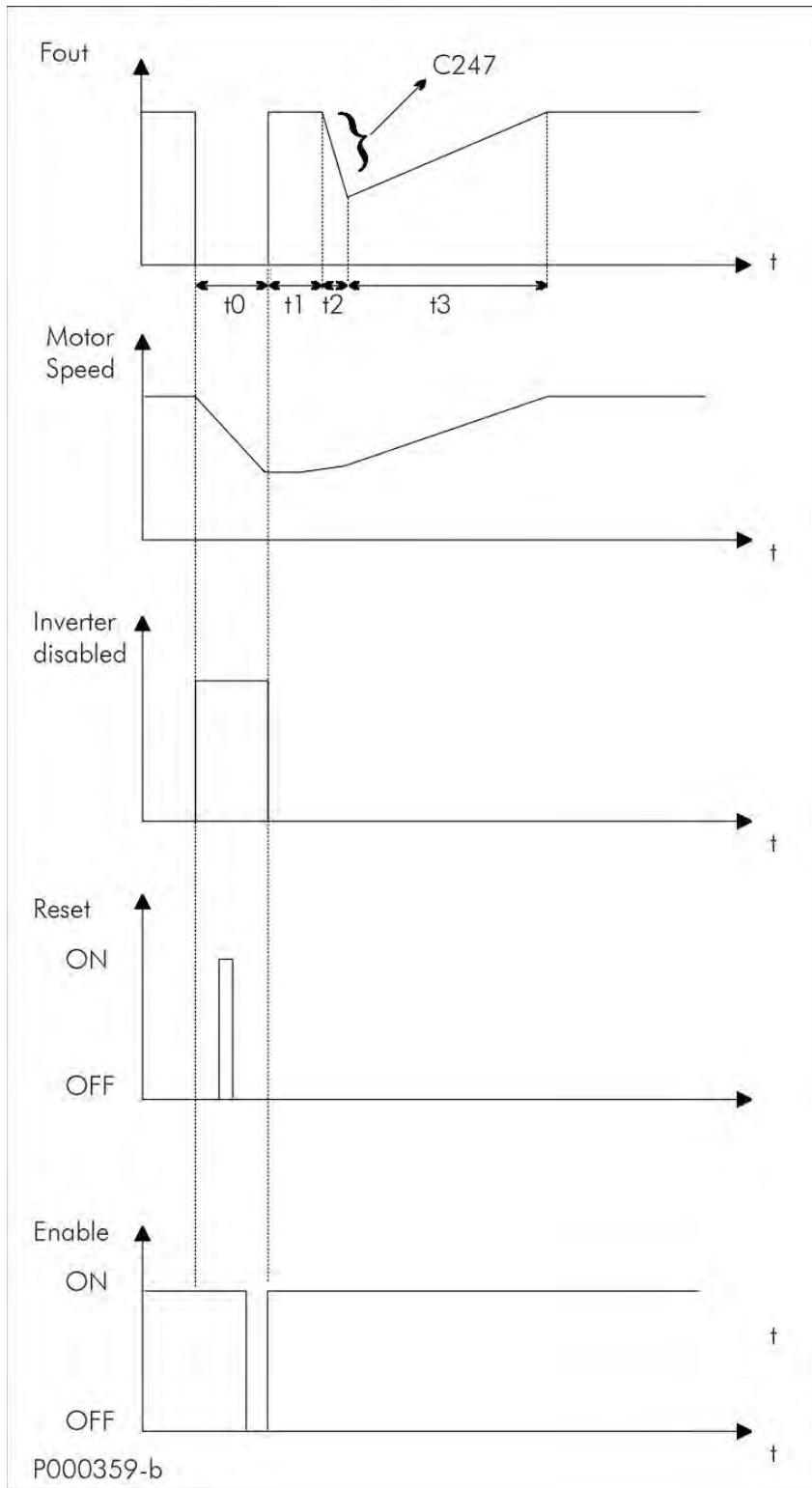

Figure 65: Speed Searching (Example 2)

Frequency, Motor Rpm, Drive Lock, **RESET** and **ENABLE** during Speed Searching (**C245** =[YES]) due to an Alarm Trip $t_{OFF} < t_{SSdis}$ (**C246**) or **C246** = 0.



NOTE

If the Safety at Start function is disabled (**C181** = [Inactive]), it is not necessary to activate and deactivate the **ENABLE** function; the Speed Searching activation would match with the **RESET** command.

42.2. List of Parameters C245 to C250

Table 116: List of Parameters C245 to C250

Parameter	FUNCTION	User Level	MODBUS Address	Default Values
C245	Speed Searching enable	ENGINEERING	1245	1: YES
C246	Run limit delay for Speed Searching	ENGINEERING	1246	1 sec
C247	Speed Searching time as % deceleration ramp	ENGINEERING	1247	10%
C248	Current used for Speed Searching	ENGINEERING	1248	75%
C249	Speed searching starting level	ENGINEERING	1249	Last speed
C250	MDI for Speed Searching enable	ENGINEERING	1250	0: Disable

C245 Speed Searching Enable

C245	Range	0 ÷ 1	0: No ÷ 1: Yes
	Default	0	0: No
	Level	ENGINEERING	
	Address	1245	
	Control	IFD, VTC	
	Function	This parameter enables the speed searching function. The Speed Searching function is enabled in the following cases: – when the ENABLE function is deactivated and reactivated before time t_{SSdis} (C246); – when the DC Braking command is disabled before the preset time is over (see the DC BRAKING MENU); – when an alarm is reset (with a reference other than 0) before time t_{SSdis} .	

C246 Run limit delay for Speed Searching

C246	Range	0; 3000	0:[Always ON] ÷ 3000 sec
	Default	1	1 sec
	Level	ENGINEERING	
	Address	1246	
	Control	IFD, VTC	
	Function	Determines the maximum allowable time passing between the drive disable and enable command when the Speed Searching function is activated. When the drive is restarted, output frequency will depend on the preset acceleration ramp. When C246 = 0: (Always ON) , speed searching will always occur, independently of the time passing between the drive disable and enable.	

C247 Frequency Decrease Rate

C247	Range	1 ÷ 1000	1 ÷ 1000%
	Default	10	10%
	Level	ENGINEERING	
	Address	1247	
	Control	IFD, VTC	
	Function	<p>This parameter sets the frequency decrease rate during the speed search stage. The frequency decrease rate (expressed in Hz/s) is given from the following formula:</p> $(f_{max} \times \mathbf{C247}) / 10$ <p>This means that when C247=100%=1, the Penta drive takes 10s to go from the max. frequency to 0Hz. When C247=10%=0.1 (default value), the system takes 100s to go from the max. frequency to 0Hz.</p> <p>The maximum frequency of the connected motor is given from the following formula:</p> $f_{max} = (npoles \times \mathbf{C029}) / (2 \times 60).$	



NOTE The frequency decrease rate is not dependent on the preset ramp times.



NOTE When the Penta drive enters the current limitation mode, the time the system takes for speed searching can be longer than the preset time.

C248 Current Used for Speed Searching

C248	Range	20 ÷ Min[peak inverter/Imot, 100]	20% ÷ Min[peak inverter/Imot, 100%]
	Default	75	75%
	Level	ENGINEERING	
	Address	1248	
	Control	IFD, VTC	
	Function	Determines the max. current level for speed searching; it is expressed as a percentage of the rated motor current.	

C249 Speed Searching Starting Level

C249	Range	0 ÷ 3	0: Last speed 1: MaxSpd/Last dir. 2: MaxSpd/Pos. Dir. 3: MaxSpd/Neg.Dir.
	Default	0	0: Last speed
	Level	ENGINEERING	
	Address	1249	
	Control	IFD, VTC	
	Function	<p>Speed Searching starts according to the value set in C249:</p> <p>C249 = 0:[Last Speed Value] – the last speed search value generated before disabling the system is used for speed searching.</p> <p>C249 = 1:[MaxSpd/LastDir.] – the max. speed programmed for the motor in the last direction of rotation of the connected motor is produced.</p> <p>C249 = 2:[MaxSpd/Pos.Dir] – the speed searching function will begin with the max. speed programmed for the motor in the positive direction of rotation independently of the last frequency value produced before disabling the drive.</p> <p>C249 = 3:[MaxSpd/Neg.Dir] – as “2”, but the direction of rotation of the connected motor will always be negative.</p>	



C250 MDI for Speed Searching Enable

C250	Range	0 ÷ 16 0 ÷ 24 if ES847 or ES870 is fitted	0 → Inactive 1 ÷ 8 → MDI1 ÷ MDI8 9 ÷ 12 → MPL1 ÷ MPL4 13 ÷ 16 → TFL1 ÷ TFL4 17 ÷ 24 → XMDI1 ÷ XMDI8
	Default	0	0: Inactive
	Level	ENGINEERING	
	Address	1250	
	Control	IFD, VTC	
	Function	If set to Inactive, it will take no effect. Otherwise, Speed Searching activates only if the preset input is active.	

43. AUTORESET MENU

43.1. Overview

The Autoreset function can be enabled in case an alarm trips. You can enter the maximum number of autoreset attempts and the time required for resetting the attempt number. If the Autoreset function is disabled, you can program an autoreset procedure at power on, which resets an active alarm when the drive is shut off. Undervoltage alarms or mains loss alarms can be saved in the fault list in the Autoreset menu.

To activate the Autoreset function, set a number of attempts other than zero in parameter **C255**. When the number of reset attempts is the same as the value set in **C255**, the autoreset function is disabled. It will be enabled again only when a time equal to or longer than the time set in **C256** has passed.

If the drive is turned off when an alarm is active, the alarm tripped is stored to memory and will be active at next power on. Regardless of the Autoreset function setup, an automatic reset of the last alarm stored can be obtained when the drive is next turned on (**C257** [Yes]). Undervoltage alarm **A047** (DC bus voltage below allowable threshold with motor running) or Mains Loss alarm **A064** (mains loss when the motor is running and the Power Down function is disabled) are not stored in the fault list when the drive is powered off (factory-setting). To enable parameter storage, set **C258** to [Yes].

43.2. List of Parameters C255 to C258

Table 117: List of Parameters C255 to C258

Parameter	FUNCTION	User Level	MODBUS Address	Default Values
C255	Autoreset attempt number	ENGINEERING	1255	0
C256	Attempt counting reset time	ENGINEERING	1256	300 sec
C257	Alarm reset at Power On	ENGINEERING	1257	0: [Disabled]
C258	Enable Undervoltage and Mains Loss alarms	ENGINEERING	1258	0: [Disabled]

C255 Autoreset Attempt Number

C255	Range	0 ÷ 100	0 ÷ 100
	Default	0	0
	Level	ENGINEERING	
	Address	1255	
	Function	If set other than 0, this parameter enables the Autoreset function and sets the max. allowable number of reset attempts. The autoreset attempt count is reset when a time equal to the time set in C256 passes starting from the last alarm tripped.	

C256 Attempt Counting Reset Time

C256	Range	0; 1000	0; 1000 sec.
	Default	300	300 sec.
	Level	ENGINEERING	
	Address	1256	
	Function	Determines the time that passes from the last alarm tripped to reset the autoreset attempt number.	

C257 Alarm Reset at Power On

C257	Range	0; 1	0: [Disabled]; 1: [Yes]
	Default	0	0: [Disabled]
	Level	ENGINEERING	
	Address	1257	
	Function	At power on, this parameter enables the automatic reset of the alarms tripped when the drive is powered off.	

C258 Enable Saving Undervoltage and Mains Loss Alarms

C258	Range	0; 1	0: [Disabled]; 1: [Yes]
	Default	0	0: [Disabled]
	Level	ENGINEERING	
	Address	1258	
	Function	This parameter saves Undervoltage and Mains Loss alarms to the fault list.	

44. MOTOR THERMAL PROTECTION MENU

44.1. Overview

The Motor Thermal Protection function protects the motor against overloads. Some Sinus Penta models offer the possibility to set the heatsink temperature for the activation of cooling fans. All relevant parameters are included in the Motor Thermal Protection menu.



NOTE

Each connected motor has its own thermal model. If the drive is used to control only one motor and its control mode is selected through the selection of the different motors, the motor thermal protection is ensured by setting PTC protection for all motors.

For each programmable motor, thermal protection can be configured in 4 modes, which can be selected with parameter **C265** (or **C268** or **C271** for motor 2 and 3 respectively), depending on the cooling system being used (configuration modes 1, 2 and 3):

Value	Descr.	IEC 34-6 Compliance	Description
0:NO	[NO]	-	The Motor Thermal Protection function is disabled;
1:YES	[No Derated]	IC410	The Motor Thermal Protection function is active with trip current I_t independent of operating speed (No derating);
2:YES A	[Forced Cooling]	IC416	The Motor Thermal Protection function is active with trip current I_t depending on operating speed, with fan-cooled motor de-rating (Forced Cooling);
3: YES B	[Fan on Shaft]	IC411	The Motor Thermal Protection function is active with trip current I_t depending on operating speed, de-rating is suitable for motors having a fan keyed to the shaft (Fan on Shaft) (factory setting).

When **C265**=1, 2 and 3, the motor thermal model is considered. The heating of a motor is proportional to the square of the current flowing (I_o^2). The Motor overheated alarm (**A075**) will trip after the time “t” computed based on the motor thermal model is over.

The alarm can be reset only after a given time depending on the thermal constant (**C267**) of the motor, thus allowing for the correct cooling of the motor.

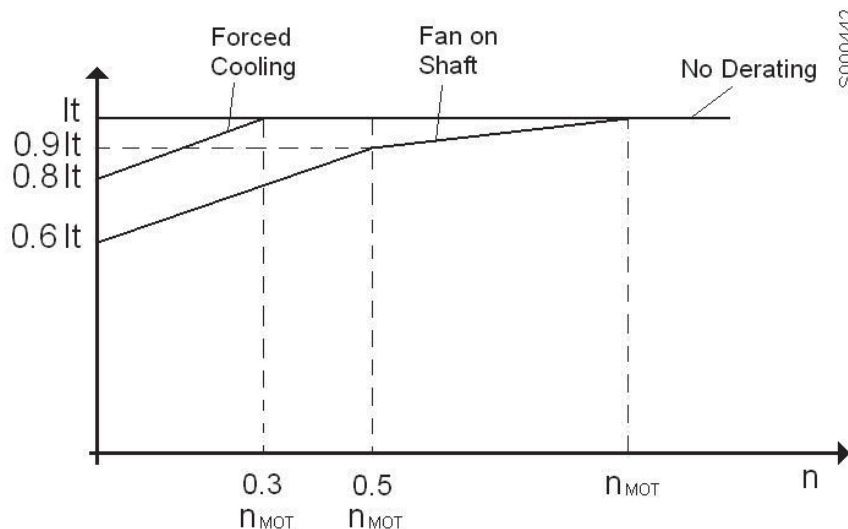

Figure 66: Trip current reduction depending on speed values

The graph above shows how trip current **It** is reduced depending on the generated speed based on the value set in parameter **C265**.



NOTE

The motor heating can be monitored with measure **M026a**. This value is expressed as a percentage of the asymptotic value that can be attained.

When **C274**=Enabled, the thermal protection function is implemented from a PTC sensor: the PTC alarm (**A055**) trips when voltage acquired by AIN2 used as a PTC signal input exceeds a preset threshold value when the characteristic temperature is attained. Alarm **A055** can be reset only if temperature decreases by 5% with respect to the trip temperature.

44.2. Choosing the Characteristic Parameters

Parameter **C266** relates to the instantaneous trip current that the internal thermal protection function will begin to monitor the current. The default value of 105% is a typical value and it is usually unnecessary to change it.

The motor thermal time is specific to the motor design and it varies between different motor manufacturers.

If the motor thermal time is unknown, the thermal time constant (**C267**) can be set up as described in the sections below (IEC Class, Maximum Locked Rotor Time – Basic and Maximum Locked Rotor Time – Enhanced). The first method is the most simple and gives an approximate result. The other two methods are more complex, but give more accurate results.

44.2.1. IEC CLASS

The motor can be protected as defined in the IEC 60947-4-1 standard for the thermal overload relays. If the protection class is known, in order to set-up the thermal protection for a certain IEC trip class, the value of **C267** can be entered as:

IEC Class	C267 [s]
10	360
20	720
30	1080

Table 118: Suggested values for the motor thermal time constant

The standard above defines a 7.2 ratio between LRC and FLC. The value to be entered in **C267** is then defined from the formula below:

$$C267 = \text{IEC Class} \times 36.$$

If the ratio between LRC and FLC is not 7.2, please refer to the graph in Figure 67.

44.2.2. MAXIMUM LOCKED ROTOR TIME – BASIC

If the IEC class is not known, then the IEC class can be approximated by the procedure described below.

The following values must be known:

- Full Load Current (FLC) of the motor
- Locked Rotor Current (LRC)
- Maximum Locked Rotor Time (LRT) or Direct On Line (DOL) Start Time

The FLC of the motor can be obtained directly from the nameplate on the motor. The LRC and LRT must be obtained from the manufacturer or the motor datasheets.

The LRC, also referred to as starting current or motor start-up current, is the current that a motor draws at start-up when full voltage is applied to the terminals.

LRT is the time a motor can safely maintain LRC from a cold start. This information might also be available as a thermal withstand curve or a thermal damage curve. If this is the case, then the LRC and LRT must be deduced from the curves.

The following formula can be applied:

$$\text{IEC Class} = \frac{\text{LRC} \times \text{LRT}}{\text{FLC} \times 6}$$

Once the approximated IEC class has been calculated, use the motor thermal time constant (**C267**) that corresponds to the closest IEC class from above.

Example 1a: the 7.5kW motor in the table below can be approximated to have a trip class of:

$$\text{IEC Class} = \frac{820 \times 20}{100 \times 6} = 27.3$$

The motor thermal time constant that you would select is IEC class 30, **C267** = 1080s.



NOTE

As an even quicker guide, the IEC trip class can generally be approximated as the locked rotor time.

Table 119: Typical datasheet for 4-pole, 50Hz-400V motors

Output [kW]	IEC Frame	Locked Rotor Current - LRC [% FLC]	Full Load Current - FLC [A]	Locked Rotor Time (cold) - LRT [s]	Rated speed [rpm]	
0.12	63	450	0.41	44	1415	
0.18	63	460	0.58	59	1400	
0.25	71	500	0.7	106	1400	
0.37	71	500	1.03	81	1395	
0.55	80	600	1.3	37	1430	
0.75	80	570	1.61	35	1420	
1.1	90S	700	2.37	31	1445	
1.5	90L	750	3.28	22	1450	
2.2	112M	720	4.42	55	1455	
4	112M	660	7.85	26	1445	
5.5	132S/M	850	10.34	26	1465	
7.5	132S/M	820	14	20	1465	Example 1a/1b
9.2	160M	560	17.4	59	1460	
11	160M	600	20.84	42	1465	
15	160L	650	28.4	37	1465	
18.5	180M/L	800	34.83	26	1470	
22	180L	790	39.4	35	1475	
30	200L	700	55.6	40	1475	
37	225S/M	720	65.2	35	1480	
45	225S/M	740	78.11	33	1480	
55	250S/M	720	95.2	37	1480	
75	250S/M	750	131.25	35	1480	
90	280S/M	780	154.41	55	1485	
110	315S/M	760	189	64	1485	
132	315S/M	780	225.53	55	1485	
150	315S/M	750	260	44	1485	
160	315S/M	760	277	44	1485	
185	355M/L	720	320	117	1490	
200	355M/L	660	342	108	1490	
220	355M/L	700	375	84	1490	
250	355M/L	690	425	79	1490	Example 2
260	355M/L	650	445	90	1490	
280	355M/L	710	471	86	1490	
300	355M/L	670	504	103	1490	
315	355M/L	670	529	92	1490	

**SINUS PENTA
PENTA MARINE**



PROGRAMMING GUIDE

330 355M/L | 650 | 554 | 70 | 1490

44.2.3. MAXIMUM LOCKED ROTOR TIME – ENHANCED

If a more precise calculation is required, when the ratio between LRC and FLC is different from 7.2, you can refer to the graph below, where the x axis shows the LRC/FLC ratio, and the y axis shows the multiplicative constant to be applied to the LRT to calculate the value of parameter **C267**:

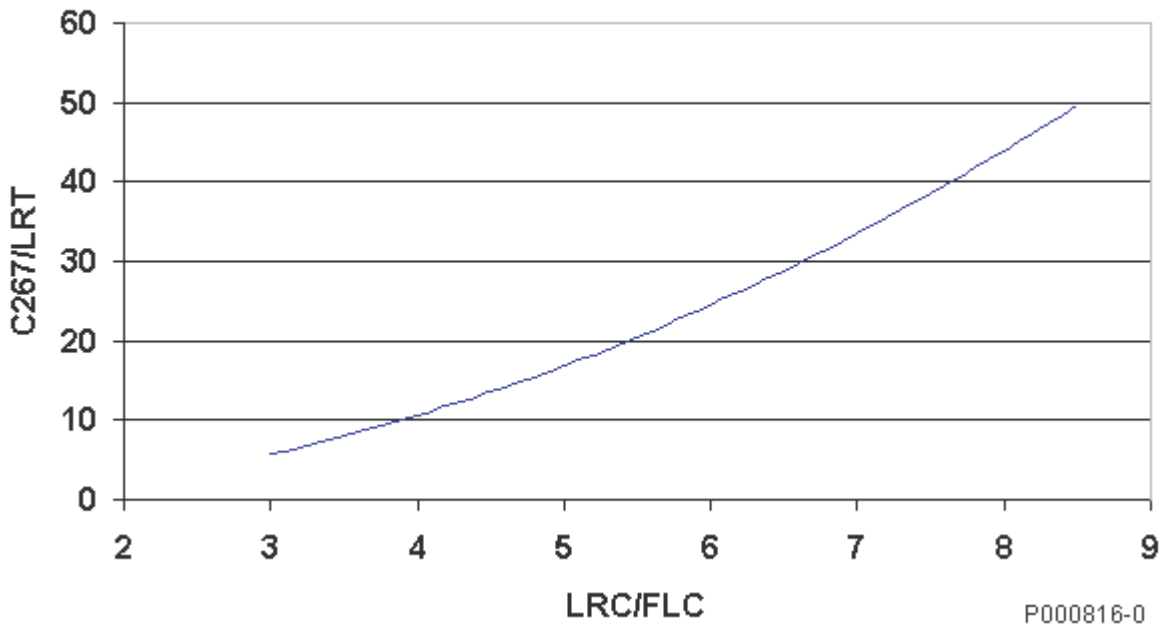

Figure 67: Set up of parameter C267 depending on the LRC/FLC ratio

Example 1b: When using a 7.5kW motor, the multiplicative constant corresponding to an LRC/FLC=8.2 is approx. 46 if referring to the graph above.

As a result, the motor thermal time constant that you would select is 27.3×46 , **C267** = 1257s, which is a more accurate value than 1080s computed in Example 1a.

Example 2: The 250kW motor in Table 119 can be approximated to have a trip class of:

$$\text{IEC Class} = \frac{690 \times 79}{100 \times 6} = 90.85$$

Because this value is not given in Table 118, the motor thermal time constant that you would select is directly **C267** = $90.85 \times 36 = 3260\text{s}$, or $90.85 \times 33 = 2998\text{s}$ if the value "33" is considered, resulting from Table 119 with a ratio between LRC/FLC=6.9.

44.3. Thermal Protection Trip Delay

The graph below shows the thermal protection trip delay depending on the IEC Class and the current flowing (which is supposed to be constant).

Parameter **C266** (trip current) is factory set to 105%.

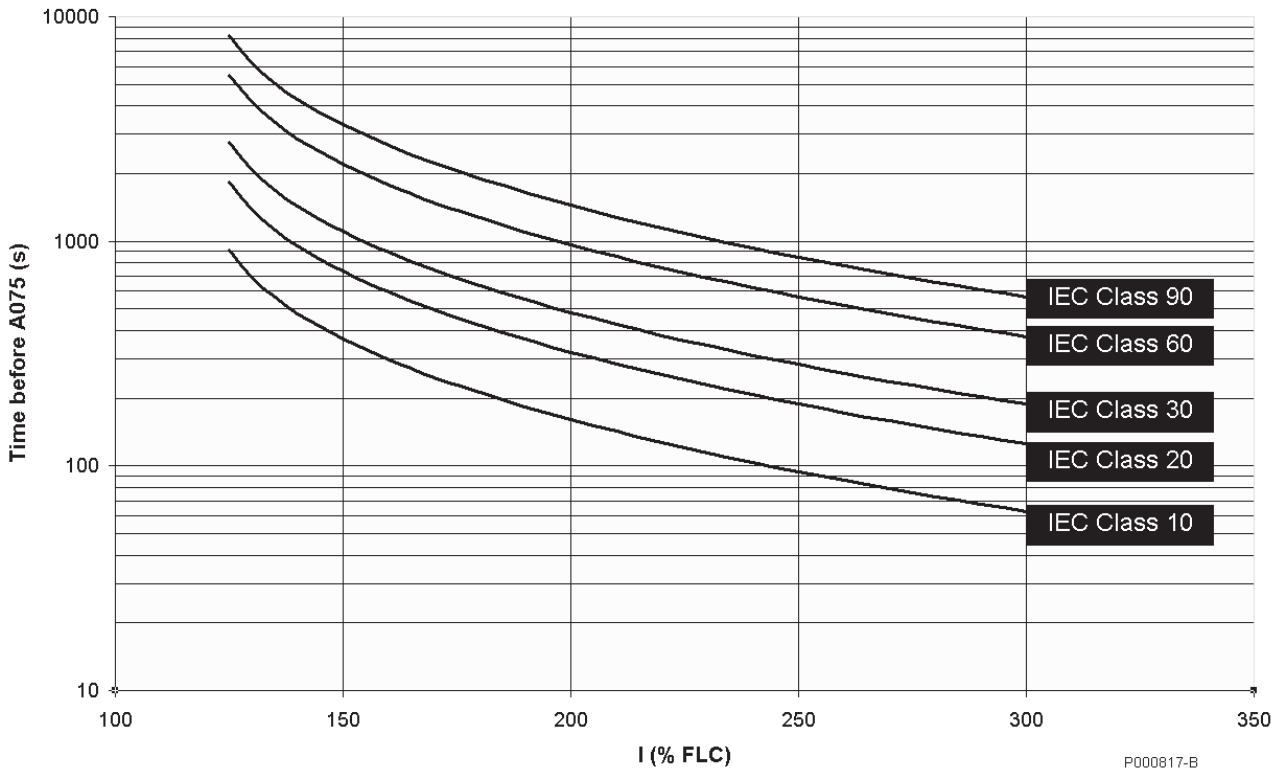

Figure 68: Trip delay of alarm A075 based on the IEC Class

Example: The protection level is compliant with IEC Class 30. If the current flowing is 200% of the FLC, alarm **A075** will trip after approx. 480s (8 minutes).

44.4. List of Parameters C264 to C274

Table 120: List of Parameters C264 to C274

Parameter	FUNCTION	User Level	MODBUS Address	Default Values
C264	Heatsink temperature for fan activation	ADVANCED	1264	50°C
C264a	Fan activation logic selector	ADVANCED	1280	0: Default
C265	Thermal Protection activation for motor 1	BASIC	1265	3: [Fan Shaft]
C266	Trip current for motor 1 [Imot%]	ADVANCED	1266	105%
C267	Thermal time constant for motor 1	BASIC	1267	720s
C268	Thermal Protection activation for motor 2	ADVANCED	1268	3: [Fan Shaft]
C269	Trip current for motor 2 [Imot%]	ADVANCED	1269	105%
C270	Thermal time constant for motor 2	ADVANCED	1270	720s
C271	Thermal Protection activation for motor 3	ADVANCED	1272	3: [Fan Shaft]
C272	Pick-up current for motor 3 [Imot%]	ADVANCED	1271	105%
C273	Thermal time constant for motor 3	ADVANCED	1273	720s
C274	PTC Thermal Protection Enable	BASIC	1274	0:[Disabled]

C264 Heatsink Temperature for Fan Activation

C264	Range	0 ÷ 50	0 ÷ 50°C
	Default	50	50°C
	Level	ADVANCED	
	Address	1264	
	Function	This parameter sets the heatsink threshold for the activation of its cooling fans according to the control logic set in C264a . This parameter is active only if C264a =0: Default or 2: By Temperature Only. The actual temperature of the heatsink can be displayed in measure parameter M064 .	

C264a Fan Activation Logic Selector

C264a	Range	0 ÷ 2	0: [Default] 1: [Always On] 2: [By Temperature Only]
	Default	0	0: [Default]
	Level	ADVANCED	
	Address	1280	
	Function	This parameter defines the control logic of the heatsink cooling fans. 0: [Default]: The heatsink cooling fans are on whenever the drive is enabled (and IGBTs are switching); when the drive is disabled, fans are off only if the heatsink temperature drops below C264 . 1: [Always On]: Fans are always on. 2: [By Temperature Only]: Fans are on only if the heatsink temperature is higher than the value set in C264 , regardless of the drive status.	



NOTE

Parameters **C264** and **C264a** take effect only for the Penta models where fans are controlled directly by the drive control board (F), as displayed on the Product screen in the PRODUCT MENU. See Table 17 and Table 18.

P	r	o	d	u	c	t		N	a	m	e				
P	E	N	T	A											
T	y	p	e		0	0	2	0		4	T		F	-	-

C265 (C268, C271) Thermal Protection Activation

C265 (Motor 1) C268 (Motor 2) C271 (Motor 3)	Range	0 ÷ 3	0 : [Disabled] 1 : [No Derating] 2 : [ForcedCool.] 3 : [Fan Shaft]
	Default	3	3: [Fan Shaft]
	Level	BASIC (C265); ADVANCED (C268, C271)	
	Address	1265; 1268; 1271	
	Function	This parameter enables the Motor Thermal Protection function. It also selects the type of thermal protection among different trip patterns.	

C266 (C269, C272) Pick-up Current

C266 (Motor 1) C269 (Motor 2) C272 (Motor 3)	Range	1 ÷ minimum between I _{max} /I _{mot} and 120%	1 ÷ minimum between I _{max} /I _{mot} and 120%
	Default	105	105%
	Level	ADVANCED	
	Address	1266, 1269, 1272	
	Function	This parameter sets the thermal protection pick-up current expressed as a percentage of the rated current of motor 1 (2, 3).	

C267 (C270, C273) Thermal Time Constant

C267 (Motor 1) C270 (Motor 2) C273 (Motor 3)	Range	1 ÷ 10800	1 ÷ 10.800 s
	Default	720	720 s (corresponding to IEC Class 20)
	Level	BASIC (C267); ADVANCED (C270, C273)	
	Address	1267; 1270; 1273	
	Function	This parameter sets the thermal time constant of the connected motor. The time constant is the time within which the calculated thermal stage has reached 63% of its final value. The motor attains its thermal time constant when it operates in constant load conditions for a time equal to approx. 5 times the constant set in this parameter.	

C274 PTC Thermal Protection Enable

C274	Range	0 ÷ 1	0: Disabled ÷ 1: Enabled
	Default	0	Disabled
	Level	ADVANCED	
	Address	1274	
	Function	This parameter enables the PTC probe (AIN2 analog input)	

**NOTE**

If the PTC thermal protection (**C274**) is enabled, the reference from **AIN2** is automatically managed as a 0 ÷10V input. The only parameter enabled for the control of AIN2 is **P064**; **P060**, **P061**, **P062** and **P063** cannot be viewed and are not considered for calculations.

45. MAINTENANCE MENU

45.1. Overview

The Maintenance menu allows setting partial counters for the drive Operation Time (OT) and Supply Time (ST). When the preset time is reached, a warning message appears (**W48** OT Time over and **W49** ST Time over respectively).

45.2. List of Parameters C275 to C278

Table 121: List of Parameters C275 to C278

Parameter	FUNCTION	User Level	MODBUS Address	DEFAULT VALUES
C275	Operation time counter reset	ENGINEERING	1275	NO
C276	Operation time threshold	ENGINEERING	1276	0h
C277	Supply time counter reset	ENGINEERING	1277	NO
C278	Supply time threshold	ENGINEERING	1278	0h

C275 Operation time counter reset

C275	Range	0 ÷ 1	0: [NO] ÷ 1 [YES]
	Default	0	NO
	Level	ENGINEERING	
	Address	1275	
	Function	This parameter resets the partial counter for the drive operation time.	

C276 Operation Time Threshold

C276	Range	0 ÷ 65000	0 ÷ 650000h
	Default	0	0h
	Level	ENGINEERING	
	Address	1276	
	Function	This parameter sets the threshold for the operation time of the drive. When this time is exceeded, Warning " W48 OT Over " appears. To reset the warning message, reset the partial counter or set the counter threshold to zero.	

C277 Supply Time Counter Reset

C277	Range	0 ÷ 1	0: [NO] ÷ 1 [YES]
	Default	0	NO
	Level	ENGINEERING	
	Address	1277	
	Function	This parameter resets the partial counter for the drive supply time.	

C278 Supply Time Threshold

C278	Range	0 ÷ 65000	0 ÷ 650000h
	Default	0	0h
	Level	ENGINEERING	
	Address	1278	
	Function	This parameter sets the threshold for the supply time of the drive. When this time is exceeded, Warning " W49 ST Over " appears. To reset the warning message, reset the partial counter or set the counter threshold to zero.	

46. PID CONFIGURATION MENU

46.1. Overview

The Sinus Penta is provided with two separate PID (Proportional, Integral, Derivative) regulators allowing performing regulation loops such as pressure control, delivery control, etc., with no need to connect external auxiliary devices.

The PID Configuration Menu defines configuration parameters for the two PID regulators.

The configuration parameters for the PID regulator can be modified only when the drive is in stand-by and they set the following variables: reference sources, feedback sources and type of PID output action.

The programming parameters for the two PID regulators, including coefficients of proportional, integral and derivative terms, output saturation, etc., are covered in the PID PARAMETERS MENU and the PID2 PARAMETERS MENU.

46.2. Operation and Structure of the PID Regulator

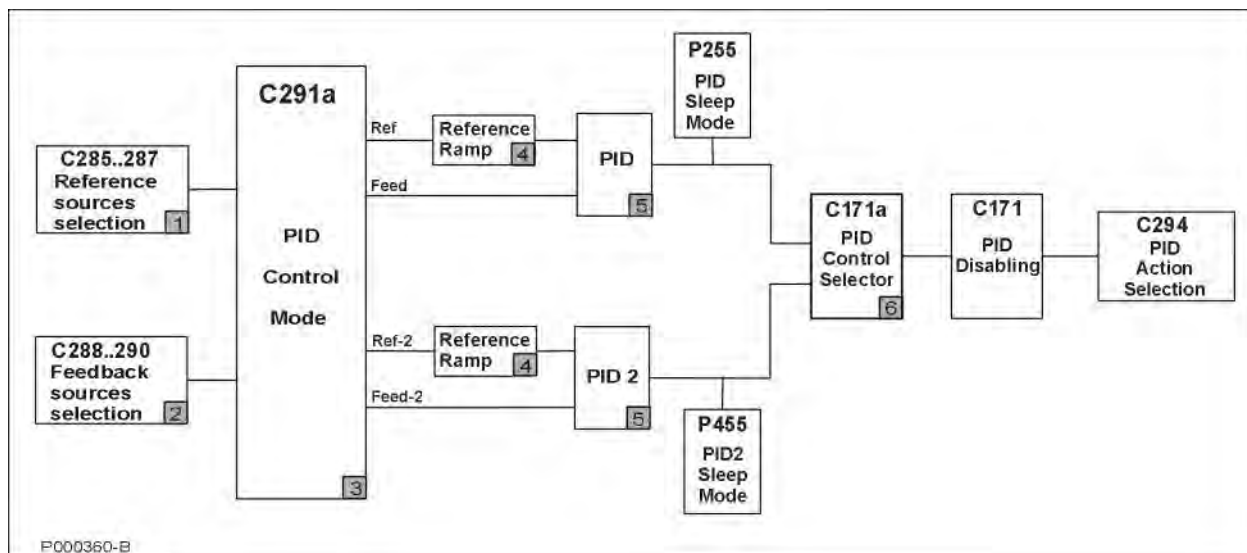

Figure 69: Structure of the PID Regulator

The figure above illustrates the block diagram of the PID regulator. Each block is described below:

Block 1: PID reference sources

Multiple reference sources can be selected at a time (up to 3 reference sources can be selected with parameters **C285**, **C286**, **C287**).

The resulting reference value depends on the setup in **C291a** (see block 3).

Dynamic selection is possible between two reference sources using the digital input configured as the source selector (see **C179** and **C179b**); this parameter has effect only if the Two PIDs mode is activated.

Block 2: PID feedback sources

Multiple feedback sources can be selected at a time (up to 3 feedback sources can be selected with parameters **C288**, **C289**, **C290**).

The resulting reference value depends on the setup in **C291a** (see block 3).

Dynamic selection is possible between two feedback sources using the digital input configured as the source selector (see **C179** and **C179b**); this parameter has effect only if the Two PIDs mode is activated.

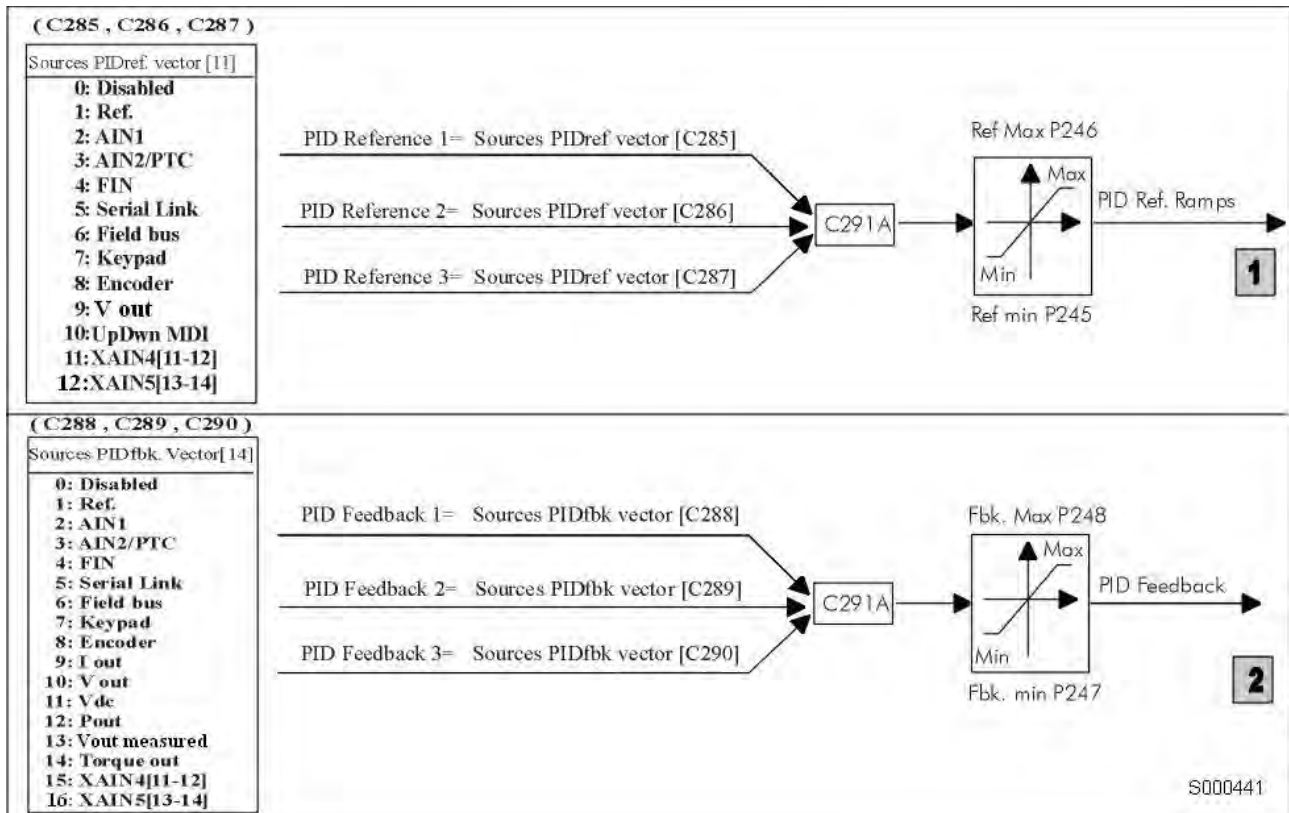

Figure 70: Reference source and feedback source selection



NOTE

The signals selected in the Sources Vector are to be considered as percentage values; therefore, analog signals are expressed as a percentage of the preset maximum values and minimum values. For example, when selecting a reference source, if **P052** Ref. max. = 8V and **P051** Ref. min. = -3V, 100% will be considered when Ref. = 8V and -100% will be considered when Ref. = -3V.



NOTE

Among the allowable variables for the PID feedback, electrical variables Iout (output current), Vout (output voltage), Vdc (DC bus voltage), Pout (output power) and Torque out (output torque – only with VTC and FOC control). Their percentage values relate to rated current values and rated voltage values of the selected motor and to 1500VDC respectively.



NOTE

In Local mode, the PID regulator is disabled if set as **C294 = Add Reference or Add Voltage**.

Block 3: PID Control Mode

This block allows applying different processing types to the feedback signals and allows enabling/disabling the PID2 integrated into the system (see **C291a**).

Block 4: Ramp over PID Reference

A ramp may be applied to the PID references sent from block 3. The same ramp is applicable for both blocks: the processed references are the ones actually used in the PID regulator. The parameters of the PID reference ramp are illustrated in the figure below. The initial rounding-off is applied to the reference whenever a new acceleration/deceleration ramp is started, while the end reference is applied at the end of each ramp.

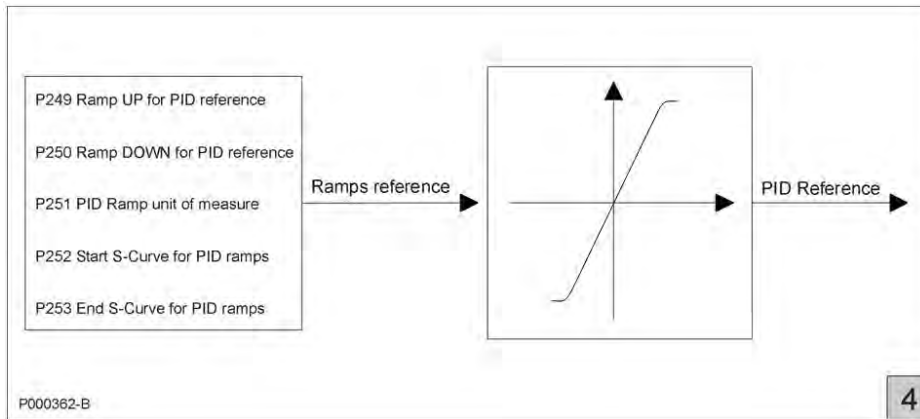

Figure 71: PID ramp reference



NOTE The PID2 ramp reference control is the same, but parameters **P2xx** are replaced with parameters **P4xx**.

Block 5: PID regulators

This is the actual PID regulator. Its output may be disabled by an external digital command (if programmed with **C171**). If the PID regulator is used as a reference source and **P255** (**P455** for PID2) is not set to zero, the PID output value control is enabled. If the PID output equals the preset minimum value for a time longer than **P255** (**P455** for PID2), the drive is automatically put on stand-by.

In the last block, the PID output is applied to the function defined by the “PID Action” parameter (**C294**).

The PID regulator structure is detailed in the diagram below (block 5).

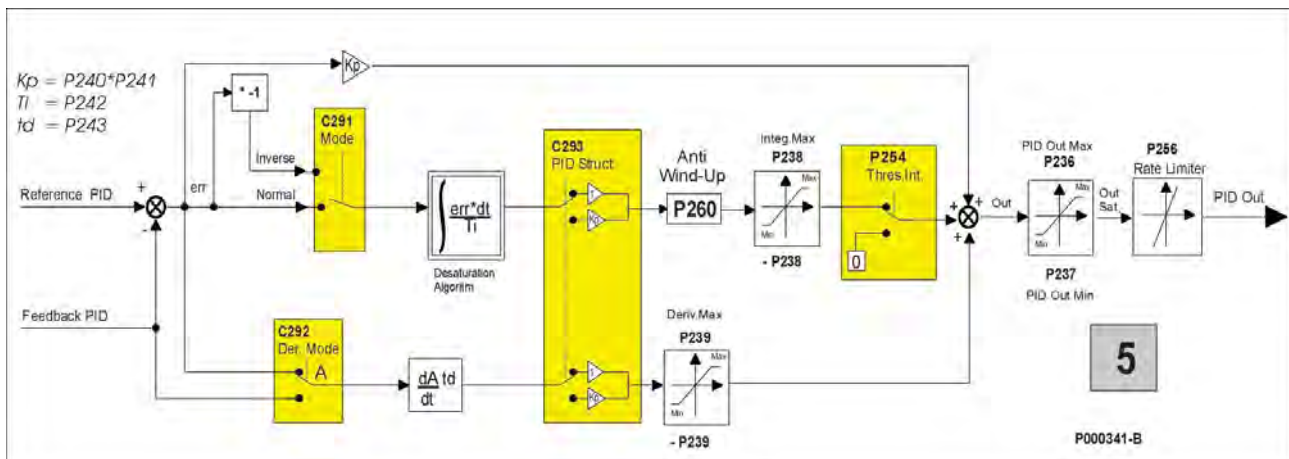

Figure 72: Details of the PID regulator structure



NOTE The PID2 structure is the same as the PID structure, but parameters **P2xx** are replaced with **P4xx** and parameter **C291** is replaced with parameter **C291b**. Parameters **C292** and **C293** are in common for PID and PID2.

Block 6: Digital input for PID control selection.

Block 6 activates only when both PIDs are enabled (**C291a = 2 PID**) or when in 2-Zone mode (**C291a = 2-Zone MIN** or **2-Zone MAX**).

In Two PIDs mode:

if **C171a = 0: Disabled**, the PID output is summed with the PID2 output;

if **C171a** is enabled, the logic state of the configured input determines which is the output of the PID regulator to be used: 0 → PID, 1 → PID2.

In 2-zone mode:

if **C171a** is enabled, when the selected input is activated, the 2-zone mode (MIN or MAX) is disabled. In that case, the PID regulator always operates on the error resulting from **C285–C288** and with parameters **P2xx**.

The PID regulator output may be used as:

- an external output;
- a speed/torque reference of the drive;
- a speed/torque reference increase or, if the IFD control is used, the PID regulator input may be used for correcting the output voltage.

If the PID regulator output is the speed reference of the drive, the selected speed/torque ramp is applied.

SERIAL LINK

The **Serial Link** source is an input from the MODBUS link: the reference value shall be written by the user to the following addresses:

Table 122: Reference sources from serial link

MODBUS Address	Input	User Level	Type of Reference	Description	Unit of Measure
1418	I031	BASIC	PID Reference	PID reference value	Set in P267
1420	I033	BASIC	PID Feedback	PID feedback value	Set in P267

46.3. List of Parameters C285 to C294

Table 123: List of Parameters C285 to C294

Parameter	FUNCTION	User Level	MODBUS Address	Default Values
C285	Selection of PID reference n. 1	ENGINEERING	1285	2:AIN1
C286	Selection of PID reference n. 2	ENGINEERING	1286	0:Disable
C287	Selection of PID reference n. 3	ENGINEERING	1287	0:Disable
C288	Selection of PID feedback n. 1	ENGINEERING	1288	3:AIN2/PTC
C289	Selection of PID feedback n. 2	ENGINEERING	1289	0:Disable
C290	Selection of PID feedback n. 3	ENGINEERING	1290	0:Disable
C291	PID operating mode	ENGINEERING	1291	0:Disable
C291a	PID control mode	ENGINEERING	1295	0:Standard SUM
C291b	PID2 operating mode	ENGINEERING	1296	1: Normal
C292	Selection of the variable for calculating the derivative term	ENGINEERING	1292	0:Measure
C293	Proportional Multiplier of derivative and integral terms	ENGINEERING	1293	0:NO
C294	PID action	ENGINEERING	1294	1:Reference

C285 (C286,C287) Selection of PID Reference n. 1 (2, 3)

C285 (C286, C287)	Range	0 ÷ 10 0 ÷ 12 if ES847 is fitted	0: Disable 1: REF 2: AIN1 3: AIN2/PTC 4: Pulse Input 5: Serial Link 6: Fieldbus 7: Keypad 8: Encoder 9: V out 10: Up Down from MDI 11: XAIN4 12: XAIN5
	Default	C285 = 2 C286 = 0 C287 = 0	C285 = 2: AIN1 C286 = 0 C287 = 0
	Level	ENGINEERING	
	Address	1285 (1286, 1287)	
	Function	<p>C285 selects the first PID reference source from the PID regulator. Up to three reference sources may be configured (285 – C287) considered as a sum. The sources are used by the PID and are expressed in percentage values (with reference to their max. value and min. value set in the References menu). If multiple reference sources are selected, their sum is considered. They are saturated between P246 and P245 (PID reference maximum and minimum value respectively).</p> <p>Source 9 (V out) is useful when C294 = 3: Voltage Sum. This is the output voltage in IFD control with no PID corrections.</p> <p>Reference sources 11 and 12 can be selected only after setting XAIN in parameter R023.</p>	

C288 (C289,C290) Selection of PID Feedback n.1 (2, 3)

C288 (C289, C290)	Range	0 ÷ 14 0 ÷ 16 if ES847 is fitted	0: Disable 1: REF 2: AIN1 3: AIN2/PTC 4: Pulse Input 5: Serial Link 6: Fieldbus 7: Keypad 8: Encoder 9: Iout 10: Vout 11: Vdc 12: Pout 13: Vout measured 14: Tout 15: XAIN4 16: XAIN5
	Default	C288 = 3 C289 = 0 C290 = 0	C288 = 3: AIN2/PTC C289 = 0: Disable C290 = 0: Disable
	Level	ENGINEERING	
	Address	1288 (1289, 1290)	
	Function	<p>C288 selects the first PID feedback source. Up to three feedback sources can be configured among the available reference sources. If multiple sources are selected, their sum is considered. They are saturated based on parameters P247 and P248 (PID feedback maximum and minimum value respectively). See also parameter C285.</p> <p>Feedback source 13 is useful if C294 = 3: Add Voltage. This is a RMS measure of the output voltage obtained from the readout of the values of two properly transformed phase-to-phase output voltages from AIN1 and AIN2.</p> <p>Feedback sources 15 and 16 can be selected only after setting XAIN in parameter R023.</p>	

C291 PID Operating Mode

C291	Range	0 ÷ 2	0: Disable 1: Normal 2: Reverse
	Default	0	0: Disable
	Level	ENGINEERING	
	Address	1291	
	Function	<p>This parameter defines how to compute the PID output. Three computing modes are available: 0: Disable, 1: Normal, 2: Reverse. If 0: Disable is selected, the PID regulator is inactive and its output is always set to zero.</p> <p>In 1: Normal mode, the actual PID output is considered.</p> <p>If 2: Reverse is selected, the output actuated by the PID regulator results from the subtraction of the max. output value set in P236 from the output obtained by the PID regulator.</p> <p>This operating mode can be used for special applications (see the Keeping Fluid Level Constant (Example) at the end of this chapter).</p>	

C291a PID Control Mode

C291a	Range	0 ÷ 7	0: Standard SUM 1: Standard DIFF 2: Average 3: Minimum 4: Maximum 5: 2-Zone MIN 6: 2-Zone MAX 7: 2 PIDs
	Default	0	0: Standard SUM
	Level	ENGINEERING	
	Address	1295	
	Function	<p>This parameter sets the PID control mode.</p> <p>Functions 0 to 4 set the processing mode of the feedback signal as detailed below.</p> <p>1) If C179 Input for Source Selection and C179b (Input for Reference Selection) are both = 0: Disabled:</p> <p>STANDARD SUM: All the selected feedback signals are summed up. STANDARD DIFF: The sum of the remaining selected feedback signals is subtracted from the feedback signal programmed in C288. AVERAGE: The resultant of the feedback is given from the arithmetical average of the selected signals. MINIMUM: The signal having the smallest value among the selected signals is considered as the feedback. MAXIMUM: The signal having the largest value among the selected signals is considered as the feedback.</p> <p>2) If C179 or C179b are enabled: STANDARD SUM: C288+C290 or C289+C290. STANDARD DIFF: C288-C290 or C289-C290. AVERAGE: AVG(C288,C290) or AVG(C289,C290). MINIMUM: MIN(C288,C290) or MIN(C289,C290). MAXIMUM: MAX(C288,C290) or MAX(C289,C290).</p> <p>The references are always summed with each other, unless they are managed with the Source Selection (see C179 and C179b).</p>	

	Function	<p>Functions 5 and 6 (2-Zone Mode) automatically disable the Source Selection function that can be programmed with C179 and C179b.</p> <p>In functions 5 and 6 only the references selected with C285-C286 and the feedback values selected with C288-C289 are used.</p> <p>2-Zone MIN: The PID operates on the system with the larger algebraic error $\text{MAX}(\text{C285-C288}, \text{C286-C289})$. This means that the system takes control of the PID having the minimum feedback in respect to its setpoint.</p> <p>2-Zone MAX: The PID operates on the system with the smaller algebraic error $\text{MIN}(\text{C285-C288}, \text{C286-C289})$. This means that the system takes control of the PID having the maximum feedback in respect to its reference.</p> <p>NOTE: When C171a Input for PID Control Selection is activated and the selected input is activated, the 2-zone (MIN or MAX) mode is disabled and the PID always operates on the error resulting from C285-C288.</p>
		<p>Function 7 (Two PIDs programming) automatically disables the Source Selection function that can be programmed with C179 and C179b.</p> <p>The two PIDs use only the signals selected with C285/C288 for PID and with C286/C289 for PID2.</p> <p>2 PID: PID and PID2 operate in parallel; the outputs of the two PIDs are matched based on the configuration of C171a: If C171a = 0: Disabled, the outputs of the two PIDs are summed to each other; If C171a is enabled, the output of the PID regulator depends on the logic state of the configured input: 0 → PID, 1 → PID2.</p>

C291b PID2 Operating Mode

C291b	Range	1 ÷ 2	1: Normal 2: Inverse
	Default	1	1: Normal
	Level	ENGINEERING	
	Address	1296	
	Function	<p>This parameter sets how to calculate the PID2 output. Two modes are available: 1: Normal, 2: Inverse. In Normal mode, the output of the PID regulator is the actual PID2 output. If 2: Inverse is selected, the error sign is reversed. The Inverse operating mode can be used for special applications only (see Keeping Fluid Level Constant (Example)).</p>	

C292 Selection of the Variable for Calculating the Derivative Term

C292	Range	0 ÷ 1	0: Measure 1: Error
	Default	0	0: Measure
	Level	ENGINEERING	
	Address	1292	
	Function	<p>This parameter sets the variable used for calculating the derivative term. By default, the derivative term is computed according to the feedback measure, but it can also be computed according to the PID error: Error = Reference – Feedback.</p>	

C293 Proportional Multiplier of Derivative and Integral Terms

C293	Range	0 ÷ 1	0: No 1: Yes
	Default	0	0: No
	Level	ENGINEERING	
	Address	1293	
	Function	This parameter defines if the proportional term is used for the multiplication of the derivative and integral terms as well. 0: No means that the proportional term DOES NOT multiply the integral term.	

C294 PID Action

C294	Range	0 ÷ 4	0: External output 1: Reference 2: Reference sum 3: Voltage sum 4: Full Ref. Sum
	Default	1	1: Reference
	Level	ENGINEERING	
	Address	1294	

Function

This parameter sets the type of implementation carried out by the PID regulator.
C294 = External Output: The PID regulator is independent of the drive operation, unless a digital input is configured for PID disabling; if the digital input closes, the PID regulator is disabled and the output is set to zero. In order to use the PID regulator output externally to the drive, configure one of the analog outputs as PID Out.

C294 = Reference: The PID regulator output is the speed/torque reference of the connected motor (depending on the type of reference configured when the motor is running); any other reference source which will be selected will be ignored. If the output is a speed reference, 100% corresponds to the max. absolute value between min. speed and max. speed set for the motor being used.

Mot1 ← Max { | C028 | ; | C029 | }
 Mot2 ← Max { | C071 | ; | C072 | }
 Mot3 ← Max { | C114 | ; | C115 | }

If the output is a torque reference, 100% is the max. absolute value between the min. limit and the max. limit of the torque of the active motor.

Mot1 ← max { | C047 | ; | C048 | }
 Mot2 ← max { | C090 | ; | C091 | }
 Mot3 ← max { | C133 | ; | C134 | }

C294 = Add Reference: The PID regulator output is a correction of the speed/torque reference of the active motor (depending on the type of reference configured when the motor is running). The percentage value of the PID output relates to the instant value of the speed/torque reference. For example, if the speed reference of the active motor is 800rpm and the PID output is ignored, if this drops to 50%, the overall speed setpoint will be $800 + 800 \cdot (50/100) = 1200$ rpm. Therefore, the PID regulator can never reversed the reference sign.

C294 = Add Voltage Out: This configuration is active only when the control algorithm of the active motor is IFD. In this case, the PID regulator output is a correction of the output voltage. The percentage value of the PID output relates to the instant voltage value.

For example, if a motor is operating in IFD mode and the drive output voltage is 200V rms at 25 Hz with PID Output = 0, if PID Output drops to -10%, the actual voltage will be $200 + 200 \cdot (-10/100) = 180$ V.

Another possible usage is the voltage drop compensation on a filter (if any) installed between the drive and the motor. To do so, set (C285, C286, C287) 9: Vout as a reference, and (C288, C289, C290) 13: Vout measured as a feedback. Two properly transformed phases are to be linked to analog inputs AIN1 e AIN2 downstream of the filter, in order to exploit the voltage actually delivered to the motor as the feedback. Only when C285, C286 or C287 are set to 9: Vout, the value percent of the PID output is referred to the nominal voltage. See "Example of Compensation of Voltage Drop in a Filter" at the end of this section.

C294 = Add Reference Full: The regulator output is a correction of the speed/torque reference of the connected motor (depending on the type of reference configured for the active motor). The value percent of the PID output is managed in the same way as C294 = Reference and is summed to the main reference.

For example, if a motor is speed-controlled with C029=1500rpm, considering the PID regulator output as null, the reference is 400rpm; if the PID output becomes 50%, the total speed setpoint is $400 + 1500 \cdot (50/100) = 1150$ rpm. In that way, if the PID output is other than zero, the reference generated will be other than zero as well, even if the main reference is null, unlike what would happen if C294 = Add Reference.



NOTE

If C294 = 0: External Output, it is not possible to set the PID reference from keypad in remote mode, unless Keypad or UpDown from MDI is set as the PID reference for parameters C285, C286, C287.

46.4. Keeping Fluid Level Constant (Example)

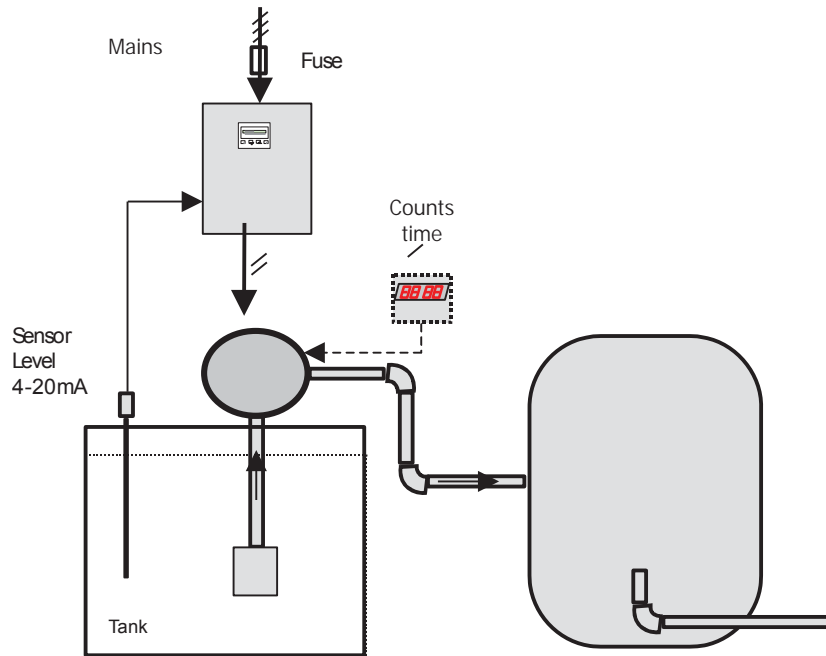

Figure 73: Keeping fluid level constant (Example)

Suppose that the maximum level in the tank is to be kept at 50% and that a 4–20mA level probe is used, with an output of 4mA for the min. level and 20mA for the max. level. The PID reference is sent from keypad, while the probe feedback is sent to AIN2/PTC analog input, which is configured as follows:

R	W	S	P060-Type of Reference for Input AIN2/PTC	2: 4-20mA [SW1-3 On]
R	W	S	P061-Reference Minimum Value for Input AIN2/PTC	4.0 mA
R	W	S	P062-Reference Maximum Value for Input AIN2/PTC	20.0 mA
R	W	S	P063-Offset for Input AIN2/PTC	0.000 mA
R	W	S	P064-Filter AIN2/PTC Constant	5 ms

The reference shall be saved from keypad, thus avoiding setting it up again when the drive is shut off.

R	W	S	P068-Storage of UP/DN values at Power Off	1: Yes
R	W	S	P068a-Reset of Speed/Torque UP/DN value at Stop	0: No
R	W	S	P068b-Reset of PID UP/DN value at Stop	0: No
R	W	S	P068c-Reset of Speed/Torque UP/DN value at Source Selection	0: No
R	W	S	P068d-Reset of PID UP/DN value at Source Selection	0: No
R	W	S	P069-Amplitude of UP/DN and KPD Reference	1: Unipolar

The PID regulator action and the PID output computing mode must also be set.

R	W	S	C285-Selection of Reference Type 1 PID	2: AIN1 [5-6]
R	W	S	C286-Selection of Reference Type 2 PID	0: Disabled
R	W	S	C287-Selection of Reference Type 3 PID	0: Disabled
R	W	S	C288-Selection of Feedback Type 1 PID	3: AIN2 [7-8]
R	W	S	C289-Selection of Feedback Type 2 PID	0: Disabled
R	W	S	C290-Selection of Feedback Type 3 PID	0: Disabled
R	W	S	C291-PID Operating Mode	1: Normal
R	W	S	C291a-PID Control Mode	0: Standard SUM
R	W	S	C291b-PID2 Operating Mode	1: Normal
R	W	S	C292-Quantity Selection to Compute Derivative Term	0: Measure
R	W	S	C293-Kp Used as a Multiplier for Integral and Derivative Terms	0: No
R	W	S	C294-PID Operation	1: Reference

The PID regulator parameters are defined in the PID PARAMETERS MENU. This configuration limits the PID output between 0 and 100% for a proper rotation of the connected pump. Set **P255** = 1000 ts: if the PID output is equal to the min. value for 5 seconds, the drive is put on stand-by.

R	W	S	P236-PID Maximum Output	<input type="text" value="100.00"/>	%
R	W	S	P237-PID Minimum Output	<input type="text" value="0.00"/>	%
R	W	S	P237a-Wake-Up mode for PID	<input type="text" value="0: Disabled"/>	
R	W	S	P237b-Wake-Up level for PID	<input type="text" value="0.00"/>	%
R	W	S	P238-Maximum Value of PID Integral Term	<input type="text" value="100.00"/>	%
R	W	S	P239-Maximum Value of PID Derivative Term	<input type="text" value="100.00"/>	%
R	W	S	P240-Proportional Coefficient Value	<input type="text" value="5.000"/>	
R	W	S	P241-Proportional Term Multiplicative Factor	<input type="text" value="0: 1"/>	
R	W	S	P242-Integral Time (Multiples of Tc)	<input type="text" value="500"/>	Tc <input type="button" value="Disabled"/>
R	W	S	P243-Derivative Time (Multiples of Tc/1000)	<input type="text" value="0"/>	mTc
R	W	S	P244-Cycle Time Tc	<input type="text" value="5"/>	ms
R	W	S	P245-PID Reference Min. Value	<input type="text" value="-100.00"/>	%
R	W	S	P246-PID Reference Max. Value	<input type="text" value="100.00"/>	%
R	W	S	P247-PID Feedback Minimum Value	<input type="text" value="-100.00"/>	%
R	W	S	P248-PID Feedback Maximum Value	<input type="text" value="100.00"/>	%
R	W	S	P249-PID Ramp UP Acceleration Time	<input type="text" value="0.00"/>	s
R	W	S	P250-PID Ramp DOWN Deceleration Time	<input type="text" value="0.00"/>	s
R	W	S	P251-Unit of Measure for PID Ramps	<input type="text" value="2: 1 s"/>	
R	W	S	P252-Start S-Curve for PID Ramps	<input type="text" value="1"/>	%
R	W	S	P253-End S-Curve for PID Ramps	<input type="text" value="1"/>	%
R	W	S	P254-PID Out Threshold Enabling Integral Implem.	<input type="text" value="0.0"/>	% Refmax
R	W	S	P255-Inverter Disabling Time for PID Output Equal to Min. Value	<input type="text" value="5"/>	s <input type="button" value="Disabled"/>
R	W	S	P256-Time Spent by PID Output from 0% to 100%	<input type="text" value="1"/>	ms

When the level of liquid in the tank exceeds the reference value set from keypad, a negative error is produced (Error = Reference – Feedback). Because the complemented output computing mode is selected and because the complemented output is the speed reference, the higher the error absolute value, the higher the PID output value. This means that the quicker the level increases, the quicker the pump suction. On the other hand, if the level is lower than the reference, a positive error is produced, because the PID output is limited to 0%, the pump will not activate; if the PID output is equal to the min. value for a timer longer than **P255 = 1000*P244 = 5sec** , the drive is put on stand-by.

46.5. Example of Compensation of Voltage Drop in a Filter

Assume that a sinusoidal filter is installed between the Penta Drive and the motor. The drive output voltage is to be adjusted to compensate for voltage drop caused by that filter. The following can be used as a feedback signal:

- 1) an analog input, connected to a signal proportional to RMS voltage, downstream of the filter, obtained by transforming and rectifying one of the phases;
- 2) two analog inputs, connected to two signals obtained by transforming two of the phases, utilized by the system to compute the RMS voltage value (see **M051a**).

46.5.1. VOLTAGE DROP COMPENSATION – FEEDBACK FROM SINGLE ANALOG INPUT

Assume that a 0-10V voltage signal proportional to RMS voltage downstream of the filter is available and that 50Vrms correspond to 1V. This signal is linked to analog input **AIN1**. The rated motor voltage (**C019**) is assumed to be 400V.

Set the following in the PID CONFIGURATION MENU:

C285	Selection of PID Reference 1	9: V out
C288	Selection of PID Feedback 1	2: AIN1
C291	PID Operation	1: Normal
C294	PID Feedback	3: Add Voltage Output

Set the following in the INPUTS FOR REFERENCES MENU:

P055	Type of Reference for AIN1 Input	3: 0-10V
P057	Ref. Max. Value Limits for AIN1 Input	10.0V

Set the following in the PID PARAMETERS MENU:

P236	Max. PID Output	100.00%
P237	Min. PID Output	0.00%
P240	Proportional Coefficient Value	1.000
P242	Integral Time	Disabled
P245	PID Reference Min. Value	0.00%
P246	PID Reference Max. Value	125.00%

The selection criterion of parameters **P057** and **P246** is the following as per the hypothesis above: 10V for **AIN1** correspond to 500Vrms, i.e. 125% of the rated motor voltage set in **C019**.

The compensated output voltage will be as follows:

$V_{out} = V_d + V_{mot} * PID_{out}$, where:

V_d is the voltage that could be delivered without compensation,

V_{mot} is the rated motor voltage (**C019**),

PID_{out} is the PID output, given by $(V_{ref} - V_{fbk})/V_{mot}$.

46.5.2. VOLTAGE DROP COMPENSATION - FEEDBACK FROM TWO ANALOG INPUTS

Assume that two +/-10V voltage signals proportional to the instantaneous voltage of two phases downstream of the filter are present and that 100V correspond to 1V. Those signals are linked to analog inputs **AIN1** and **AIN2**. Assume that the rated motor voltage (**C019**) is 400V. If the voltage downstream of the filter is a sinusoidal voltage, the voltage sinusoids will be $400 \cdot \text{SQRT}(2) = 565\text{V}$ at a rated voltage of 400Vrms. The amplitude of signals **AIN1** and **AIN2**, damped 1:100, will be 5.65V, i.e. within the allowable range.

Set the following in the PID CONFIGURATION MENU:

C285	Selection of PID Reference 1	9: V out
C288	Selection of PID Feedback 1	13: V out measured
C291	PID Operation	1: Normal
C294	PID Feedback	3: Add Voltage Output

Set the following in the INPUTS FOR REFERENCES MENU:

P055	Type of Reference for AIN1 Input	0: +/-10V
P057	Ref. Max. Value Limits for AIN1 Input	8.0V
P060	Type of Reference for AIN2 Input	0: +/-10V
P062	AIN2 Input Value Producing Maximum Reference	8.0V

Set the following in the PID PARAMETERS MENU:

P236	Max. PID Output	100.00%
P237	Min. PID Output	0.00%
P240	Proportional Coefficient Value	1.000
P242	Integral Time	Disabled
P245	PID Reference Min. Value	0.00%
P246	PID Reference Max. Value	200.00%

The selection criterion of parameters **P057** and **P246** is the following as per the hypothesis above: 8Vrms in **AIN1** and **AIN2** correspond to 800Vrms, i.e. 200% of the rated motor voltage set in **C019**. The upper limit for parameter **P246** is 200%, so **P057** = 10.00V, **P247** = $1000/400 = 250\%$, equivalent from a numerical point of view, would not be possible.

The compensated output voltage will be as follows:

$V_{out} = V_d + V_{mot} \cdot \text{PIDout}$, where:

V_d is the voltage delivered without compensation,

V_{mot} is the rated motor voltage (**C019**),

PIDout is the PID output, given by $(V_{ref} - V_{fbk})/V_{mot}$.

47. BRIDGE CRANE MENU

47.1. Overview

For hoisting applications, it may be necessary to consider the opening/closing of a mechanical brake in order to obtain a proper control of the connected motor.

For example, if a mechanical brake takes 500ms to open after the start command – the delay is due to the type of brake – the motor will not be running for 500ms, while the speed reference increases the preset ramp. The motor then pushes against the brake, and when it can rotate freely, the motor torque will not match with the torque required to move the connected load.

If the speed setpoint is kept to zero for a given time after sending the start command (considering the time required for the mechanical brake to open), the motor control will implement the proper torque for the motor speed as soon as the motor can start rotating.

The brake closure can be controlled via a digital input that is properly set up; when the drive detects the brake closure, it automatically adjusts the value of the current injected into the motor to the fluxing value. This is required when, during the hoisting stage, the mechanical brake closes when the load is suspended after reaching negligible speed. In that case, the torque produced by the motor is capable of keeping the load hanging; when the brake closes, this has no effect on the speed regulator, because the motor is already standstill. When the brake closes, no torque must be generated to keep the load hanging, so the current injected into the motor drops to the value required for the motor fluxing.



NOTE The Bridge CRANE menu is used for VTC and FOC Control only.



NOTE For safety reasons, the brake closure contact must be an NO contact (closed contact only when the brake is engaged).



NOTE In addition to parameters **C300** to **C302**, a dedicated MDO must be set as 6: BRAKE (see the DIGITAL OUTPUTS MENU).

47.2. List of Parameters C300 to C303

Table 124: List of Parameters C300 to C303

Parameter	FUNCTION	User Level	MODBUS Address	DEFAULT VALUES
C300	Positive pretensioning torque [%Cmot]	ENGINEERING	1300	0.0%
C301	Positive pretensioning torque time	ENGINEERING	1301	0ms
C300a	Negative pretensioning torque [%Cmot]	ENGINEERING	1308	0.0%
C301a	Time period of negative pretensioning torque	ENGINEERING	1309	0ms
C302	Closed brake input (NO contact)	ENGINEERING	1302	0: None
C303	Brake activation during Tracking Error	ENGINEERING	1304	1: Yes

C300/C300a Pretensioning Torque [%Cmot]

C300/C300a	Range	-5000 ÷ +5000	-500.0% ÷ +500.0%
	Default	0	0.0 %
	Level	ENGINEERING	
	Address	1300/1308	
	Control	VTC and FOC	
	Function	<p>If not set to zero, this parameter defines the torque value (expressed as a percentage of the rated torque of the selected motor) reached before the speed ramp starts after sending a START command.</p> <p>After sending a START command, the drive brings the motor torque to the level set in C300/C300a and torque is adjusted by the speed loop for the time set in C301/C301a in order to keep the motor standstill. Once this time has elapsed, the speed ramp can start and the motor follows the required speed profile.</p> <p>The torque sign defines the running direction.</p> <p>The sign of the speed reference determines which value percent is to be used; C300 is for the positive sign, C300a is for the negative sign.</p>	

C301/C301a Pretensioning Torque Time

C301/C301a	Range	0 ÷ 32000	0 ÷ 32000 ms
	Default	0	0
	Level	ENGINEERING	
	Address	1301/1309	
	Control	VTC and FOC	
	Function	<p>Delay time passing between the start command and the speed ramp start. During this time, the motor torque output is set in C300/C300a to keep the load suspended.</p>	

C302 Closed Brake Input (NO contact)

C302	Range	0 ÷ 12 0 ÷ 20 if ES847 or ES870 is installed	0 → Inactive 1 ÷ 8 → MDI1 ÷ MDI8 9 ÷ 12 → MPL1 ÷ MPL4 13 ÷ 16 → TFL1 ÷ TFL4 17 ÷ 24 → XMDI1 ÷ XMDI8
	Default	0	0 → Inactive
	Level	ENGINEERING	
	Address	1302	
	Control	VTC and FOC	
	Function	<p>This parameter determines the digital input assigned to the mechanical brake closure feedback (NO contact, which closes only when the brake is engaged). When the brake closure is detected after a deceleration ramp, the current required for motor fluxing is injected into the motor. If no digital input is available for the detection of the brake closure, set max. time in C183, in order to avoid injecting current into the motor after the deceleration ramp. When the motor is not running, the START command is disabled and the speed setpoint is at zero for a time longer than the one set in C183, the drive will be put on standby.</p>	

C303 Brake Activation during Tracking Error

C303	Range	0 ÷ 1	0: No 1: Yes
	Default	1	1: Yes
	Level	ENGINEERING	
	Address	1304	
	Control	VTC and FOC	
	Function	<p>This parameter defines if, in case of tracking error (ENCODER/FREQUENCY INPUTS MENU, parameters C192, C193, C194), the output of the electromechanical brake is to be disabled, thus causing the activation of the brake itself.</p> <p>0: No, in case of tracking error, the brake command output is kept active. 1: Yes, in case of tracking error, the brake command output is deactivated, thus causing the brake activation.</p> <p>If C194=1 (or =2 in some cases), the tracking error triggers alarm A080. In case of alarm, the brake output is disabled, independently of the value in C303.</p>	

48. DATE AND TIME MENU

48.1. Overview

The Clock/Calendar of the control board (RTC – Real Time Clock) is based on the Clock/Calendar of the Data Logger ES851 (please refer to the Motor Drives Accessories - User Manual).



NOTE

The Data and Time Menu may be accessed only if the Data Logger board is installed (even the ES851 RTC version only) and if parameter **R021** Data Logger setting is set to 2: ENABLE.

The clock/calendar can be updated via special parameters. The display/keypad permits to immediately update the clock/calendar: just select the Set Time page or the Set Date page and press **ENTER**. Press **ESC** to go to the next field; press **ENTER** to confirm.

If you use the serial link of the inverter where the Data Logger is installed, the Clock/Calendar is viewed in the measure parameters below. To update the Clock/Calendar via serial link, set the new values in **C310** to **C315** and send the edit command (**C316**).

Parameters **R050** to **R053** set the rules for daylight saving time.

Press Save/Enter for TIME setting

→

C 3 1 4 S e t T I M E

D S T : O F F

> 1 6 : 2 9 : 5 5

2 0 1 1 / J A N / 0 1 : S A T

First page of the Date and Time menu on the display/keypad

Press Save/Enter for DATE setting

→

C 3 1 0 S e t D A T E

 1 6 : 2 9 : 5 5

> 2 0 1 1 / J A N / 0 1 : S A B

Second page of the Date and Time menu on the display/keypad

The date and time on the display/keypad are represented by the measures below:

Time (Hours)

Time (Hours)	Range	0 ÷ 23	0 ÷ 23 hours
	Active	This measure is available only if the Data Logger ES851 is installed and activated (R021 = ENABLE).	
	Address	3342	
	Level	BASIC	
	Function	Time - hours (current value).	

Minutes

Minutes	Range	0 ÷ 59	0 ÷ 59 min
	Active	This measure is available only if the Data Logger ES851 is installed and activated (R021 = ENABLE).	
	Address	3343	
	Level	BASIC	
	Function	Minutes (current value).	

Seconds

Seconds	Range	0 ÷ 59	0 ÷ 59 sec
	Active	This measure is available only if the Data Logger ES851 is installed and activated (R021 = ENABLE).	
	Address	3344	
	Level	BASIC	
	Function	Seconds (current value).	

Day of the Week

Day of the Week	Range	1 ÷ 7	1: Mon. 2: Tues. 3: Wed. 4: Th. 5: Fri. 6: Sat. 7: Sun.
	Active	This measure is available only if the Data Logger ES851 is installed and activated (R021 = ENABLE).	
	Address	3345	
	Level	BASIC	
	Function	Day of the week (current value).	

Day of the Month

Day of the Month	Range	1 ÷ 31	1 ÷ 31 days
	Active	This measure is available only if the Data Logger ES851 is installed and activated (R021 = ENABLE).	
	Address	3346	
	Level	BASIC	
	Function	Day of the month (current value).	

Daylight Saving Time

Daylight Saving Time	Range	0 ÷ 2	0 ÷ 2
	Active	This measure is available only if the Data Logger ES851 is installed and activated (R021 = ENABLE).	
	Address	528	
	Level	BASIC	
	Function	Status of the DST: 0: Inactive 1: Inactive from less than 1 hour 2: Active	



Month

Month	Range	1 ÷ 12	1: January 2: February 3: March 4: April 5: May 6: June 7: July 8: August 9: September 10: October 11: November 12: December
	Active	This measure is available only if the Data Logger ES851 is installed and activated (R021 = ENABLE).	
	Address	3347	
	Level	BASIC	
	Function	Month (current value).	

Year

Year	Range	2000 ÷ 2099	2000 ÷ 2099 years
	Active	This measure is available only if the Data Logger ES851 is installed and activated (R021 = ENABLE).	
	Address	3348	
	Level	BASIC	
	Function	Year (current value).	

48.2. List of Parameters C310 to C316

Table 125: List of Parameters C310 to C316

Parameter	FUNCTION	User Level	MODBUS Address
C310	Day of the week to be changed	ADVANCED	1241
C311	Day of the month to be changed	ADVANCED	1242
C312	Month to be changed	ADVANCED	1243
C313	Year to be changed	ADVANCED	1244
C314	Time (Hours) to be changed	ADVANCED	1245
C315	Time (Minutes) to be changed	ADVANCED	1246
C316	Clock/Calendar editing command	ADVANCED	1248

C310 Day of the Week to be changed

C310	Range	1 ÷ 7	1: Mon. 2: Tues. 3: Wed. 4: Th. 5: Fri. 6: Sat. 7: Sun.
	Default	1	1: Mon.
	Level	ADVANCED	
	Active	This parameter can be viewed and changed only if the Data Logger ES851 is installed and activated (R021 = ENABLE).	
	Address	1241	
	Function	This parameter sets the value of the day of the week to be changed.	

C311 Day of the Month to be changed

C311	Range	1 ÷ 31	1 ÷ 31 days
	Default	1	Day 1
	Level	ADVANCED	
	Active	This parameter can be viewed and changed only if the Data Logger ES851 is installed and activated (R021 = ENABLE).	
	Address	1242	
	Function	This parameter sets the value of the day of the month to be changed.	

C312 Month to be changed

C312	Range	1 ÷ 12	1: January 2: February 3: March 4: April 5: May 6: June 7: July 8: August 9: September 10: October 11: November 12: December
	Default	1	1: January
	Level	ADVANCED	
	Active	This parameter can be viewed and changed only if the Data Logger ES851 is installed and activated (R021 = ENABLE).	
	Address	1243	
	Function	This parameter sets the value of the month to be changed.	

C313 Year to be changed

C313	Range	2000 ÷ 2099	2000 ÷ 2099 years
	Default	0	Year 2000
	Level	ADVANCED	
	Active	This parameter can be viewed and changed only if the Data Logger ES851 is installed and activated (R021 = ENABLE).	
	Address	1244	
	Function	This parameter sets the value of the year to be changed.	

C314 Time (hours) to be changed

C314	Range	0 ÷ 23	0 ÷ 23 hours
	Default	0	0 hours
	Level	ADVANCED	
	Active	This parameter can be viewed and changed only if the Data Logger ES851 is installed and activated (R021 = ENABLE).	
	Address	1245	
	Function	This parameter sets the time (hour) to be changed.	

C315 Minutes to be changed

C315	Range	0 ÷ 59	0 ÷ 59 min.
	Default	0	0 minutes
	Level	ADVANCED	
	Active	This parameter can be viewed and changed only if the Data Logger ES851 is installed and activated (R021 = ENABLE).	
	Address	1246	
	Function	This parameter sets the time (minutes) to be changed.	

C316 Clock/Calendar Editing Command

C316	Range	0 ÷ 1	0 ÷ 1
	Default	0	0
	Level	ADVANCED	
	Active	This parameter can be viewed and changed only if the Data Logger ES851 is installed and activated (R021 = ENABLE).	
	Address	1248	
	Function	<p>If this parameter is set to 1, all the values set in parameters C310 to C315 are written and stored to the clock/calendar of the board and the measures described above are instantly changed.</p> <div style="display: flex; align-items: center;">  <div> <p>CAUTION</p> <p>Also unchanged parameters are written to the clock/calendar. Make sure that unchanged parameters are correct.</p> </div> </div>	

49. TIMED FLAGS MENU

49.1. Overview

The Timed Flag Menu includes the parameters setting the four timed flags for the inverter, TFL1..4. The following data items are set for each timed flag: activation time (Time ON), deactivation time (Time OFF), days of the week when activation shall occur.

The timed flags may be used as they were digital inputs, both when managing digital outputs (MDO) and when managing virtual digital outputs (MPL). It is also possible to assign the same control functions that can be associated to the other digital inputs (see DIGITAL INPUTS MENU).



NOTE The Timed Flags Menu may be accessed only if the Data Logger board is installed (even the ES851 RTC version only) and if parameter **R021** Data Logger setting is set to 2: ENABLE.

49.2. Examples

Every time flag features 3 parameters (Hour, Minute, Second) setting the activation time of the flag itself; 3 parameters (Hour, Minute, Second) setting the deactivation time of the flag itself; 1 parameter setting the days of the week when the flag shall activate. If the activation time precedes the deactivation time, the flag will have the TRUE logic value at the activation time, whilst it will have the FALSE logic value at the deactivation time in the days of the week concerned. If the activation time is subsequent to the deactivation time, the flag will have the TRUE logic value at the activation time, whilst it will have the FALSE logic value at the deactivation time of the following day.

Example 1:

C330	TFL1: Time ON – Hour	08
C331	TFL1: Time ON – Minutes	00
C332	TFL1: Time ON – Seconds	00
C333	TFL1: Time OFF – Hour	20
C334	TFL1: Time OFF – Minutes	00
C335	TFL1: Time OFF – Seconds	00
C336	TFL1: Days of the week	1000000

The timed flag TFL1 is TRUE from 8:00:00AM to 08:00:00PM every Monday.

Example 2:

C330	TFL1: Time ON – Hour	20
C331	TFL1: Time ON – Minutes	00
C332	TFL1: Time ON – Seconds	00
C333	TFL1: Time OFF – Hour	08
C334	TFL1: Time OFF – Minutes	00
C335	TFL1: Time OFF – Seconds	00
C336	TFL1: Days of the week	1000000

The timed flag TFL1 is TRUE from 08:00:00PM on every Monday to 8:00:00AM on every Tuesday.

49.3. List of Parameters from C330 to C357

Table 126: List of Parameters C330 to C357

Parameter	FUNCTION	User Level	DEFAULT VALUES	MODBUS Address
C330	TFL1: Time ON – Hour	ADVANCED	0	271
C331	TFL1: Time ON – Minutes	ADVANCED	0	272
C332	TFL1: Time ON – Seconds	ADVANCED	0	273
C333	TFL1: Time OFF – Hour	ADVANCED	0	274
C334	TFL1: Time OFF – Minutes	ADVANCED	0	275
C335	TFL1: Time OFF – Seconds	ADVANCED	0	276
C336	TFL1: Days of the week	ADVANCED	0	277
C337	TFL2: Time ON – Hour	ADVANCED	0	278
C338	TFL2: Time ON – Minutes	ADVANCED	0	279
C339	TFL2: Time ON – Seconds	ADVANCED	0	280
C340	TFL2: Time OFF – Hour	ADVANCED	0	281
C341	TFL2: Time OFF – Minutes	ADVANCED	0	282
C342	TFL2: Time OFF – Seconds	ADVANCED	0	283
C343	TFL2: Days of the week	ADVANCED	0	284
C344	TFL3: Time ON – Hour	ADVANCED	0	285
C345	TFL3: Time ON – Minutes	ADVANCED	0	286
C346	TFL3: Time ON – Seconds	ADVANCED	0	287
C347	TFL3: Time OFF – Hour	ADVANCED	0	288
C348	TFL3: Time OFF – Minutes	ADVANCED	0	289
C349	TFL3: Time OFF – Seconds	ADVANCED	0	290
C350	TFL3: Days of the week	ADVANCED	0	291
C351	TFL4: Time ON – Hour	ADVANCED	0	292
C352	TFL4: Time ON – Minutes	ADVANCED	0	293
C353	TFL4: Time ON – Seconds	ADVANCED	0	294
C354	TFL4: Time OFF – Hour	ADVANCED	0	295
C355	TFL4: Time OFF – Minutes	ADVANCED	0	296
C356	TFL4: Time OFF – Seconds	ADVANCED	0	297
C357	TFL4: Days of the week	ADVANCED	0	298

C330 (C337, C344, C351) Hour of Activation of the Timed Flag TFL1 (TFL2, TFL3, TFL4)

C330 C337 C344 C351	Range	0 ÷ 23	0 ÷ 23
	Default	0	0
	Level	ADVANCED	
	Address	271 (278, 285, 292)	
	Function	Sets the hour of activation of the timed flag TFL1 (TFL2, TFL3, TFL4) .	

C331 (C338, C345, C352) Minute of Activation of the Timed Flag TFL1 (TFL2, TFL3, TFL4)

C331 C338 C345 C352	Range	0 ÷ 59	0 ÷ 59
	Default	0	0
	Level	ADVANCED	
	Address	272 (279, 286, 293)	



	Function	Sets the hour of activation of the timed flag TFL1 (TFL2, TFL3, TFL4) .
--	-----------------	--

C332 (C339, C346, C353) Second of Activation of the Timed Flag TFL1 (TFL2, TFL3, TFL4)

C332 C339 C346 C353	Range	0 ÷ 59	0 ÷ 59
	Default	0	0
	Level	ADVANCED	
	Address	273 (280, 287, 294)	
	Function	Sets the second of activation of the timed flag <u>TFL1 (TFL2, TFL3, TFL4)</u> .	

C333 (C340, C347, C354) Hour of Deactivation of the Timed Flag TFL1 (TFL2, TFL3, TFL4)

C333 C340 C347 C354	Range	0 ÷ 23	0 ÷ 23
	Default	0	0
	Level	ADVANCED	
	Address	274 (281, 288, 295)	
	Function	Sets the hour of deactivation of the timed flag <u>TFL1 (TFL2, TFL3, TFL4)</u> .	

C334 (C341, C348, C355) Minute of Deactivation of the Timed Flag TFL1 (TFL2, TFL3, TFL4)

C334 C341 C348 C355	Range	0 ÷ 59	0 ÷ 59
	Default	0	0
	Level	ADVANCED	
	Address	275 (282, 289, 296)	
	Function	Sets the minute of deactivation of the timed flag <u>TFL1 (TFL2, TFL3, TFL4)</u> .	

C335 (C342, C349, C356) Second of Deactivation of the Timed Flag TFL1 (TFL2, TFL3, TFL4)

C335 C342 C349 C356	Range	0 ÷ 59	0 ÷ 59
	Default	0	0
	Level	ADVANCED	
	Address	276 (283, 290, 297)	
	Function	Sets the second of deactivation of the timed flag <u>TFL1 (TFL2, TFL3, TFL4)</u> .	



C336 (C343, C350, C357) Days of the Week of the Activation of the Timed Flag TFL1 (TFL2, TFL3, TFL4)

C336 C343 C350 C357	Range	0000000b ÷ 1111111b binary	0 ÷ 127
	Default	0	0
	Level	ADVANCED	
	Address	277(284, 291, 298)	
	Function	Sets the second of deactivation of the timed flag TFL1 (TFL2, TFL3, TFL4) . Every bit corresponds to a day of the week: bit 1 corresponds to Monday, bit 7 corresponds to Sunday. Example: 1111100: flag TLF1 will activate every day of the week but Saturday and Sunday. 0000000: the flag will never activate. 1111111: the flag will activate every day.	

50. SERIAL COMMUNICATIONS

50.1. Overview

Sinus Penta drives may be connected to other devices through a serial link. This allows reading and writing the parameters accessed through the remotable display/keypad.



Brammer also supplies the RemoteDrive software package allowing controlling the drive through a computer connected via serial link.

This application offers the following functionality: image copy, keypad emulation, oscilloscope functions and multifunction tester, data logger, history data table compiler, parameter setting and data reception–transmission–storage from and to a computer, scan function for the automatic detection of the connected inverters (up to 247 connected inverters).

50.2. MODBUS–RTU PROTOCOL

Messages and data are sent by means of standard protocol MODBUS in RTU mode. This standard protocol performs control procedures using an 8–bit binary representation.

In RTU mode, a message begins with a silence interval equal to 3.5 times the transmission time of a character.

If the character transmission stops for a time equal to 3.5 times the transmission time of a character, the controller will consider this time interval as the end of the message. Similarly, a message starting with a shorter silence time is considered as part of the previous message.

Message beginning	Address	Function	Data	Error control	End of message
T1–T2–T3–T4	8 bits	8 bits	n x 8 bits	16 bits	T1–T2–T3–T4

Use parameter R004 (TimeOut) to increase the silence time interval up to max. 10000ms for the systems that do not recognize standard timeouts.

Address

The address field acknowledges any value ranging from 1 to 247 as the address of the slave peripheral device. The master device queries the peripheral device specified in the address field; the peripheral device will respond with a message containing its address to let the master device know which the slave source of the response is. A master device query with a 0 address is addressed to all slave devices, which will not respond at all (broadcast mode).

Function

The function related to the message may be chosen within the legal field ranging from 0 to 255. A response of the slave device to a message of the master device will simply return the function code to the master device if no error took place; otherwise, the most significant bit in this field is set to 1.

The only functions allowed are **03h: Read Holding Register**, **06h Write Single Register** and **10h: Preset Multiple Register** (see below).



Data

The data field contains any additional information for the function being used.

Error Control

The error control is performed through the CRC (Cyclical Redundancy Check) method. The 16-bit value of the relevant field is computed when the message is sent by the transmitter and is then re-computed and checked by the receiver.

CRC Register is computed as follows:

1. CRC Register is set to FFFFh
2. Exclusive OR is executed between CRC register and the first 8 bits of the message; the result is saved to a 16-bit register.
3. This register is right-shifted of one place.
4. If the right bit is 1, exclusive OR is executed between the 16-bit register and value 101000000000001b.
5. Steps 3 and 4 are repeated until 8 shifts are performed.
6. Exclusive OR is performed between the 16-bit register and the next 8 bits of the message.
7. Steps 3 to 6 are repeated until all message bytes are processed.
8. The result is a CRC, that is attached to the message by sending the least significant byte as the first byte.

Supported Functions

03h: Read Holding Register

Allows reading the register state of the slave device. This function does not allow the broadcast mode (address 0).

Additional parameters are the address of the basic digital register to be read and the output number to be read.

QUERY	RESPONSE
Slave address	Slave address
03h Function	03h Function
Register address (high)	Byte number
Register address (low)	Data
Register N. (high)	...
Register N. (low)	Data
Error correction	Error correction

06h: Write Single Register

Sets the state of one register for the slave device. In broadcast mode (address 0), the state of that register is set for all the connected slave devices. Additional parameters are the register address and the relevant value.

QUERY	RESPONSE
Slave address	Slave address
06h Function	06h Function
Register 1 addr. (Hi)	Register 1 addr. (Hi)
Register 1 addr. (Lo)	Register 1 addr. (Lo)
Data (high)	Data (high)
Data (low)	Data (low)
Error correction	Error correction

10h: Preset Multiple Register

Sets the state of consecutive multiple registers (max 123) for the slave device. In broadcast mode (address 0), the state of those registers is set in all the connected slave devices. Additional parameters are the basic register address, the number of registers to be set, the relevant value and the number of bytes used for the data items.

QUERY	RESPONSE
Slave address	Slave address
10h Function	10h Function
Register 1 addr. (Hi)	Register 1 addr. (Hi)
Register 1 addr. (Lo)	Register 1 addr. (Lo)
Register N. (Hi)	Register N. (Hi)
Register N. (Lo)	Register N. (Lo)
Byte number	Error correction
Data (Hi)	
Data (Lo)	
...	
Data (Hi)	



Data (Lo) Error correction	
-------------------------------	--

Error Messages

If a message error is detected, the inverter will send a message to the master:

Slave address	Function (MSB = 1)	Error code	Error correction
---------------	--------------------	------------	------------------

The error code meaning is the following:

Code		DESCRIPTION
0x01	ILLEGAL FUNCTION	The function sent by the Master is different from 0x03 (Read Holding Registers) and 0x10 (Preset Multiple Registers).
0x02	ILLEGAL ADDRESS	The Master wrote to or read from an illegal address.
0x03	ILLEGAL DATA VALUE	The numerical value the Master tried to write is not included in the correct range.
0x06	DEVICE BUSY	The drive refused the Master writing attempt (e.g. because it is running and a Cxxx parameter is activated).
0x07	ANOTHER USER WRITING	Other users are writing to the selected parameter when the Master is trying to write to this parameter (e.g. display/keypad in editing mode or Upload/Download to/from keypad).
0x09	BAD ACCESS LEVEL	The parameter the Master is trying to write to is not included in the selected User Level (e.g. it is trying to write an ADVANCED parameter when the BASIC user level is selected).

51. SERIAL LINKS MENU

51.1. Overview



NOTE

Please refer to the Sinus Penta's Installation Guide for the description of the serial links and connections.



NOTE

For a greater immunity against communication interference, an optional optoisolated serial board (ES822) may be used instead of RS485 serial link. Serial links RS232 and RS485 can interface with ES822 board. Please refer to the Sinus Penta's Installation Guide for the description of the optional optoisolated board.



NOTE

The parameters described in this menu are **Rxxx** parameters. Once changed and saved, they become active only when the drive is next switched on or when the control board is reset (by holding down the **RESET** key for more than 5 secs).

Drives of the SINUS PENTA series may be connected to peripheral devices through a serial link. This enables both reading and writing of all parameters normally accessed through the display/keypad. Two-wire RS485 is used, which ensures better immunity against disturbance even on long cable paths, thus reducing the communication errors.

Two serial links are available. **Serial Link 0** is provided with a 9-pole, male D connector; **Serial Link 1** is provided with an RJ45 connector (or a three-phone connector) connected to the display/keypad.



NOTE

The display/keypad connected through RJ45 connector dialogues correctly with the drive using the default values preset in the parameter set for serial link 1.

The drive will typically behave as a slave device (i.e. it only answers to queries sent by another device). A master device (typically a computer) is then needed to start serial communications.

The following items may be configured for both serial links:

1. The drive MODBUS address.
2. The drive response delay to a Master query.
3. The baud rate of the serial link (expressed in bits per second);
4. The time added to the 4 byte-time;
5. The serial link watchdog (which is active if the relevant parameter is not set at 0);
6. The type of parity used for serial communications.

51.1.1. WATCHDOG ALARMS

The Watchdog alarms determined by the serial link may be the following:

- **A061** Serial alarm n.0 WDG
- **A062** Serial alarm n.1 WDG
- **A081** Keypad Watchdog

The first two alarms trip when no legal message is sent from the serial link to the drive for a time longer than the time set in the relevant watchdog parameters; **these alarms are active only if parameters R005 or R012 are set other than zero.**



NOTE

Alarms **A061** and **A062** do not trip if, due to the parameters in the CONTROL METHOD MENU or due to the status of the SOURCE SELECTION or LOC/REM inputs (see DIGITAL INPUTS MENU), the information sent via serial link is not currently used for the commands or the references.



The third alarm trips only if the **display/keypad used as a reference/command source** detects a communication loss for a time longer than 2 seconds.

51.2. List of Parameters R001 to R013

Table 127: List of Parameters R001 to R013

Parameter	FUNCTION	User Level	MODBUS Address	Default Values
R001	Drive MODBUS Address for Serial Link 0 (D9-pole)	ENGINEERING	588	1
R002	Response Delay for Serial Link 0 (D9-pole)	ENGINEERING	589	5msec
R003	Baud Rate for Serial Link 0 (D9-pole)	ENGINEERING	590	6:38400 bps
R004	Time added to 4byte-time for Serial Link 0 (D9-pole)	ENGINEERING	591	2msec
R005	Watchdog time for Serial Link 0 (D9-pole)	ENGINEERING	592	0.0sec
R006	Parity Bit for Serial Link 0 (D9-pole)	ENGINEERING	593	1:Disabled 2 Stop-bit
R008	Drive MODBUS address for Serial Link 1 (RJ45)	ENGINEERING	595	1
R009	Response Delay for Serial Link 1 (RJ45)	ENGINEERING	596	5 msec
R010	Baud Rate for Serial Link 1 (RJ45)	ENGINEERING	597	6:38400 bps
R011	Time Added to 4byte-time for Serial link 1 (RJ45)	ENGINEERING	598	2msec
R012	Watchdog Time for Serial Link 1 (RJ45)	ENGINEERING	599	0.0sec
R013	Parity Bit for Serial Link 1 (RJ45)	ENGINEERING	600	1:Disabled 2 Stop-bit

R001 Drive MODBUS Address for Serial Link 0 (D9-pole)

R001	Range	1 ÷ 247	1 ÷ 247
	Default	1	1
	Level	ENGINEERING	
	Address	588	
	Function	This parameter determines the address assigned to the drive connected through RS485 of serial link 0 (9-pole, male D connector).	

R002 Response Delay for Serial Link 0 (D9-pole)

_R002	Range	1 ÷ 1000	1 ÷ 1000 msec
	Default	5	5 msec
	Level	ENGINEERING	
	Address	589	
	Function	This parameter determines the drive response delay after a master query sent through serial link 0 (9-pole, male D connector).	

R003 Baud Rate for Serial Link 0 (D9-pole)

R003	Range	1 ÷ 7	1: 1200 bps 2: 2400 bps 3: 4800 bps 4: 9600 bps 5: 19200 bps 6: 38400 bps 7: 57600 bps
	Default	6	6: 38400bps
	Level	ENGINEERING	
	Address	590	
	Function	This parameter determines the baud rate, expressed in bits per second, for serial link 0 (9-pole, male D connector).	

R004 Time added to 4-Byte-Time for Serial Link 0 (D9-pole)

R004	Range	1 ÷ 10000	1 ÷ 10000 msec
	Default	2	2 msec
	Level	ENGINEERING	
	Address	591	
	Function	This parameter determines the limit time when no character is received from serial link 0 (9-pole, male D connector) and the message sent from the master to the drive is considered as complete.	

R005 Watchdog Time for Serial Link 0 (D9-pole)

R005	Range	0 ÷ 60000	0 ÷ 6000.0 sec
	Default	0	0.0 sec
	Level	ENGINEERING	
	Address	592	
	Function	If not set at zero, this parameter determines the time limit after which alarm A061 WDG Serial 0 Alarm trips if the drive does not receive any legal message through serial link 0 (9-pole, male D connector).	

R006 Parity Bit for Serial Link 0 (D9-pole)

R006	Range	0 ÷ 3	0: Disabled 1 Stop-bit 1: Disabled 2 Stop-bit 2: Even (1 Stop bit) 3: Odd (1 Stop bit)
	Default	1	1: Disabled 2 Stop-bit
	Level	ENGINEERING	
	Address	593	
	Function	This parameter determines whether the parity bit is used or not when creating the MODBUS message through serial link 0 (9-pole, male D connector).	

R008 Drive MODBUS Address for Serial Link 1 (RJ45)

R008	Range	1 ÷ 247	1 ÷ 247
	Default	1	1
	Level	ENGINEERING	
	Address	595	
	Function	This parameter determines the address assigned to the drive connected to the network through RS485 of serial link 1 (RJ45 connector).	

NOTE

The display/keypad connected through RJ45 connector dialogues correctly with the drive using the default values preset in the parameter set for serial link 1 (RJ45).

R009 Response Delay for Serial Link 1 (RJ45)

R009	Range	1 ÷ 1000	1 ÷ 1000 msec
	Default	5	5 msec
	Level	ENGINEERING	
	Address	596	
	Function	This parameter determines the drive response delay after a master query sent through serial link 1 (RJ45 connector).	

R010 Baud Rate for Serial Link 1 (RJ45)

R010	Range	1 ÷ 7	1: 1200 bps 2: 2400 bps 3: 4800 bps 4: 9600 bps 5: 19200 bps 6: 38400 bps 7: 57600 bps
	Default	6	6: 38400bps
	Level	ENGINEERING	
	Address	597	
	Function	This parameter determines the baud rate, expressed in bits per second, for serial link 1 (RJ45 connector).	

R011 Time Added to 4-Byte-Time for Serial Link 1 (RJ45)

R011	Range	1÷10000	1 ÷ 10000 msec
	Default	2	2 msec
	Level	ENGINEERING	
	Address	598	
	Function	This parameter determines the time limit when no character is received from serial link 1 (RJ45 connector) and the message sent from the master to the drive is considered as complete.	

R012 Watchdog Time for Serial Link 1 (RJ45)

R012	Range	0 ÷ 60000	0 ÷ 6000.0 sec
	Default	0	0.0 sec
	Level	ENGINEERING	
	Address	599	
	Function	If this parameter is not set at zero, it determines the time limit after which alarm A062 WDG Serial Link 1 Alarm trips if the drive does not receive any legal message through serial link 1 (RJ45 connector).	

R013 Parity Bit for Serial Link 1 (RJ45)

R013	Range	0 ÷ 3	0: Disabled 1 Stop-bit 1: Disabled 2 Stop-bit 2: Even (1 Stop bit) 3: Odd (1 Stop bit)
	Default	1	1: Disabled 2 Stop-bit
	Level	ENGINEERING	
	Address	600	
	Function	This parameter determines whether the parity bit is used or not when creating the MODBUS message through serial link 1 (RJ45 connector).	

52. FIELDBUS CONFIGURATION MENU

52.1. Overview

NOTE

See the OPTIONAL BOARDS FOR FIELDBUS section in the Sinus Penta's Motor Drives Accessories - User Manual for the description of the optional board required.

NOTE

The parameters included in this menu are **Rxxx** parameters. Once saved, they are active only when the drive is next switched on or when the control board is reset (by holding down the **RESET** key for more than 5 secs).

CAUTION

This menu is not applicable to ES919 communications boards (see relevant section in the Sinus Penta's Motor Drives Accessories - User Manual). ES919 boards act as gateways and change the **MODBUS** RS485 packets into the packets of each protocol being used. The exchanged parameters are all the **Mxxx** measures from the Sinus Penta to the Master and all the **Ixxx** inputs from the Master to the Sinus Penta (as detailed in the MEASURES MENU, Table 89 and Table 91).

52.1.1. ALARM A070 (COMMUNICATION SUSPENDED)

Alarm **A070** trips if the Sinus Penta is not sent any legal message via FIELDBUS within the timeout set in parameter **R016**. Set parameter **R016** = 0 to disable alarm **A070**.

A legal message is as follows:

- **PROFIdrive**: The master drive writes bit 11=1 of the Control Word (see PROFIdrive COMMUNICATIONS BOARD - Installation and Programming Guide).
- **Other Fieldbuses**: The master drive writes the digital input word (word 5 - **M035**) with bit 15=1 or as set in parameter **R018b**.

A legal message is the word of the digital inputs (**M035**) with bit 15=1 written by the master. Important: this is enabled only when the drive receives the first message with this bit =1.

Do the following to reset alarm **A070**:

- restore communication between the Master drive and the Sinus Penta;
- Re-activate the control of bit 15 of the digital input word as above (bit 11 of the Control Word when using PROFIdrive);
- Send a reset command to the board.

If communications between the Master and the Slave (Penta) cannot be restored, alarm **A070** is reset after setting parameter **R016** to zero and after resetting the Penta drive. When the drive is next powered on, resetting the alarm reset will affect the drive control board.

NOTE

Alarm **A070** does not trip if, due to the parameters in the CONTROL METHOD MENU or due to the status of the SOURCE SELECTION or LOC/REM inputs (see DIGITAL INPUTS MENU), the information sent via serial link is not currently used for the commands or the references.

52.2. List of Parameters R016 to R018b and I080

Table 128: List of Parameters R016 to R018b and I080

Parameter	FUNCTION	User Level	MODBUS Address	Default Values
R016	Fieldbus Watchdog Time	ENGINEERING	603	0 ms
R017	Analog Outputs Controlled by the Fieldbus	ENGINEERING	604	000b
R018	Node Address in the Fieldbus	ENGINEERING	230 bit 0-7	0
R018a	Fieldbus BaudRate	ENGINEERING	230 bit 8-11	125k
R018b	Type of Fieldbus Watchdog	ENGINEERING	230 bit 12-15	0 → bit 15 at 1
I080	IP Address Reset	ENGINEERING	519	Inactive

R016 Fieldbus Watchdog Time

R016	Range	0 ÷ 60000	0 ÷ 60000 ms
	Default	0	0 ms
	Level	ENGINEERING	
	Address	603	
	Function	If not set to zero, this parameter determines the time limit after which A070 Fieldbus WDG trips if no legal writing is received from the fieldbus.	



NOTE

The Watchdog activates only once the drive has received the first legal message from the master, as described in Alarm A070 (Communication Suspended). This avoids untimely activation due to different start times between the master and the drive.

R017 Analog Outputs Controlled by the Fieldbus

R017	Range	000b ÷ 111b binary 0000h ÷ 0007h hex 0 ÷ 7 decimal	000b → None 001b → AO1 010b → AO2 100b → AO3
	Default	000b	000b → None
	Level	ENGINEERING	
	Address	604	
	Function	To select analog outputs controlled by the fieldbus, select the bit corresponding to the analog output to be controlled. Example: R017 = 0011b = 3 decimal → analog outputs AO1 and AO2 are controlled directly by the fieldbus, irrespective of their configuration in the ANALOG AND FREQUENCY OUTPUTS MENU.	

R018 Node Address in the Fieldbus

R018	Range	0 ÷ 126 for Profibus 0 ÷ 63 for DeviceNet	0 ÷ 126 for Profibus 0 ÷ 63 for DeviceNet
	Default	0	0
	Level	ENGINEERING	
	Validity	Boards: B40 Profibus and DeviceNet	
	Address	230 bit 0-7	
	Function	This is the slave address. This parameter is active only for Profibus and DeviceNet fieldbus with B40 boards.	

R018a Fieldbus Baud Rate

R018a	Range	0÷3	0 → 125k 1 → 250k 2 → 500k 3 → Autodetect
	Default Level	0	0 → 125k
	Validity	Boards: B40 DeviceNet	
	Address	230 bit 8-11	
	Function	This is the slave baud rate in bps. It is active only for DeviceNet fieldbus with B40 boards.	

R018b Type of WatchDog

R018b	Range	0÷2	0 → bit 15 at 1 1 → bit 15 in toggle 2 → with B40 state
	Default Level	0	0 → bit 15 at 1
	Address	230 bits 12-15	
	Validity	Boards: B40	
	Function	<p>Indicates the type of active WatchDog:</p> <p>0 → after having established a connection to the Master device for the first time, if R016 > 0, the system checks if bit 15 of word 5 (digital inputs from Fieldbus) is set to 1. If the bit drops to zero for a time longer than R016, alarm A070 Fieldbus WDG trips.</p> <p>1 → After having established a connection to the Master device for the first time, if R016 > 0, the system checks if bit 15 of word 5 (digital inputs from Fieldbus) continuously changes 0-1. If the bit is kept at one of the two values for a time longer than R016, A070 alarm A070 Fieldbus WDG trips.</p> <p>2 → After having established a connection to the Master device for the first time, if R016 > 0, the system checks if the status of B40 board is kept in Connect status. If the Disconnect status is kept for a time longer than R016, A070 alarm A070 Fieldbus WDG trips.</p> <p>It is active only for B40 boards.</p>	

Table 129: Coding of Parameters R018, R018a and R018b

bit [15..12]	bit [11..8]	bit [7..0]
R018b	R018a	R018

I080 IP Address Reset

I080	Range	0 ÷ 1	0 → Inactive 1 → Address reset
	Default	This is not a parameter: the input is set to zero at power on and whenever the command is executed.	
	Level	ENGINEERING	
	Validity	Boards: B40 Modbus TCP-IP, Profinet, Ethernet IP and EtherCAT	
	Address	519	
	Function	<p>Pressing the button forces the following after the board is reset:</p> <p>IP → 192.168.0.2 subnet mask → 255.255.255.0 gateway → 0.0.0.0 and DHCP disabled.</p> <p>This parameter is active only for Modbus TCP-IP, Profinet, Ethernet IP and EtherCAT fieldbus with B40 boards.</p>	

52.3. Exchanged Parameters

The tables below state the Sinus Penta parameters exchanged via Fieldbus.

Each table contains:

- 1) the parameter code;
- 2) its description;
- 3) its range;
- 4) its unit of measure (also indicated on the display);
- 5) the ratio between the Sinus Penta value (exchanged via Fieldbus) and the represented hardware value (as displayed).



NOTE Each parameter is exchanged as an integer value with 16-bit sign (-32768 to +32767).



NOTE Bytes are exchanged in **big-endian mode** (the most significant value is stored to the smallest memory address).
When using an Intel based master/PLC chipset, then the data below will be byte-swapped.



NOTE The PLC must enter all the exchange variables, with no exception. If required, it is possible to suppress all the variables in sequence after suppressing the variable desired.
For example, if all data are required from the Master to the Slave up to "Commands for digital outputs from Fieldbus", the first six variables shall be entered by the PLC. Variables from 7 on may not be entered to the PLC.

52.3.1. FROM THE MASTER TO THE SINUS PENTA

Word	1) Code	2) Description	3) Range	4) Unit of Measure	5) Scaling
1	M042	Speed reference/limit from FIELDBUS (integer portion)	- 32000 ÷ + 32000	rpm	1
2	M043	Speed reference/limit from FIELDBUS (decimal portion)	- 99 ÷ + 99	rpm	x 100
3	M045	Torque reference/limit from FIELDBUS	- 5000 ÷ + 5000	%	x 10
4	M047	PID reference from FIELDBUS	- 10000 ÷ + 10000	%	x 100
5	M035 + M036b	Digital and Auxiliary Digital Inputs from FIELDBUS	-	-	-
6	-	Command for Digital Outputs from FIELDBUS	-	-	-
7	AO1	Analog Output 1 controlled by FIELDBUS	+ 167 ÷ + 2833	-	-
8	AO2	Analog Output 2 controlled by FIELDBUS	+ 167 ÷ + 2833	-	-
9	AO3	Analog Output 3 controlled by FIELDBUS	+ 167 ÷ + 2833	-	-
10	M049	PID Feedback from FIELDBUS	- 10000 ÷ + 10000	-	x 100

The parameter exchange memory zone may also be used to read and write all the Penta drive's parameters by referring to their Modbus address.

Word	1) Number	2) Description	3) Range	4) Unit of measure	5) Ratio
11	Type of cycle	Read or write cycle	Allowable values 0x80, 0x40	-	1
12	Address	Modbus address of the variable	0 ÷ 8191	-	1

		to be read/written			
13	Value	Value to be written to the Modbus address	-32768 ÷ +32767	-	1

Word 1: Speed reference/limit from FIELDBUS (integer portion)

Word 1 of the memory map details the integer portion of the speed reference (**M042**) in either IFD, VTC or FOC mode.

bit [15..8]	bit [7..0]
Speed reference integer portion	

The speed reference from the FIELDBUS is obtained by adding the decimal portion to the integer portion (see Word 2).

This value is included in the global speed reference of the drive (measure **M000**) along with the other reference sources if at least one of parameters **C143** to **C146** is set as 6:FieldBus.

The speed limit from FIELDBUS is significant if parameter **C147** is set as 6:FieldBus and the type of reference of the active motor (parameters **C011** / **C054** / **C097**) is set as 2:Torque with Speed Limit.

Word 2: Speed reference/limit from FIELDBUS (decimal portion)

Word 2 details the decimal portion of the speed reference (**M043**) ONLY IN FOC MODE. The value sent by the Master to the Sinus Penta as the decimal portion of the speed reference must be multiplied by 100. In order to send a speed reference of XXX.50rpm, the low byte of the word must contain the value 50₁₀ or 00110010₂ (0.50₁₀ x 100 = 50₁₀).

Example: **M042**=210; **M043**=50 ⇒ speed ref. = 210.50 rpm

bit [15..8]	bit [7..0]
Speed reference decimal portion	

Word 3: Torque reference/limit from FIELDBUS

The torque reference from the FIELDBUS (**M045**) is significant if at least one of parameters **C143** to **C146** is set as 6:FieldBus and if the type of reference of the active motor (parameters **C011/C054/C097**) is set as 1:Torque or as 2:Torque with Speed Limit, or if the drive is in slave mode from digital input.

The torque limit from the FIELDBUS is significant if parameter **C147** is set as 6:FieldBus.

The value sent by the Master to the Sinus Penta as the torque reference/torque limit must be multiplied by 10. In order to send a torque reference/torque limit of 50%, the word must contain the value 500₁₀ or 111110100₂ (50%₁₀ x 10 = 500₁₀).

bit [15..8]	bit [7..0]
Torque reference/limit	

Word 4: PID reference from FIELDBUS

The PID reference (**M047**) can be sent from the fieldbus if at least one of the parameters **C285** to **C287** is set as 6:Fieldbus.

The value sent by the Master to the Sinus Penta as the PID reference must be multiplied by 100. E.g. In order to send a PID reference of 50%, the word must contain the value 5000₁₀ or 111110100₂ (50%₁₀ x 100 = 5000₁₀).

bit [15..8]	bit [7..0]
PID reference from FIELDBUS	

Word 5: Digital and Auxiliary Digital Inputs from FIELDBUS

The virtual digital inputs via the Fieldbus are the low byte of the word:

bit [7..0]							
MDI8	MDI7	MDI6	MDI5	MDI4	MDI3 (RESET)	MDI2	MDI1

The virtual auxiliary digital inputs from Fieldbus are given in the high byte of the word:

bit 15	bit [14..8]						
XMDI8/ Watchdog	XMDI7	XMDI6	XMDI5	XMDI4	XMDI3	XMDI2	XMDI1

The logic status of these bits is included in the overall status of the drive digital inputs (measure **M031**) along with the other command sources if at least one of the parameters **C140 ÷ C142** is set as 6:FieldBus.



NOTE

Auxiliary digital input XMDI8, allocated to bit 15 of Word 5, may be controlled only if:
R016 = 0 (inactive watchdog), or
R016 > 0 (active watchdog) and **R018b** = 2.



CAUTION

If **R016** > 0 (active watchdog), bit 15 is controlled via parameter **R018b**:

- **R018b** = 0/1: see the description of the parameter
- **R018b** = 2: the bit controls input XMDI8 and is independent of the watchdog control.

Word 6: Command for Digital Outputs from FIELDBUS

Digital commands from FIELDBUS are the 4 lower bytes of the word:

bit [15..4]	bit [3..0]			
	CMD 4	CMD 3	CMD 2	CMD 1

Byte format:

Bit	Command	Position in the selection vector
0	Fbus CMD 1	D34
1	Fbus CMD 2	D35
2	Fbus CMD 3	D36
3	Fbus CMD 4	D37

Columns 2 and 3 state the name and position of the commands sent via fieldbus.

Example: to control digital output 1 via fieldbus through command 4, set the parameters below in the DIGITAL OUTPUTS MENU:

- P270** = 1: Digital Digital Output Mode
- P271** = D37: Fbus CMD4 Variable A Selection
- P278** = 1: True Output Logic Level

Words 7, 8, 9: Analog Outputs controlled by FIELDBUS

Parameter **R017** needs to be properly set up to distinguish which Analog Outputs are to be controlled by the Fieldbus.

Byte format:

Bit	Analog Output controlled by the fieldbus
0	AO1
1	AO2
2	AO3

Example: **R017** = $011_2 = 3_{10}$ → analog outputs AO1 and AO2 are controlled directly by the fieldbus, independently of their configuration in the ANALOG AND FREQUENCY OUTPUTS MENU.

The correspondence between the exchanged value and the actual value (in volts) of the analog outputs is as follows:

Exchanged value	Voltage (V)	Current (mA)
+ 2833	+ 10	+ 20 mA
+ 1500	0	0
+ 167	- 10	- 20 mA

Word 10: PID feedback from FIELDBUS

The PID feedback (**M049**) can be sent from the fieldbus if at least one of the parameters **C288** to **C290** is set as 6:Fieldbus.

The value sent by the Master to the Sinus Penta as the PID feedback must be multiplied by 100.
E.g. In order to send a PID feedback of 50%, the word must contain the value 5000_{10} or 111110100_2 ($50\%_{10} \times 100 = 5000_{10}$).

bit [15..8]	bit [7..0]
PID feedback from FIELDBUS	

Word 11: Type of cycle required

The word states the cycle required:

0x40: Write cycle

0x80: Read cycle

For the "Read cycle", the field including the read address (Word 12) is to be completed beforehand.

For the "Write cycle", the field including the write address (Word 12) as well as the field including the value to be written (Word 13) are to be completed beforehand.



NOTE

At the end of each read/write cycle or between any two cycles, enter value "0x00" in Word 11.

Word 12: Modbus address of the variable to read/write

Includes the Modbus address of the variable to be read (read cycle) or written (write cycle).



NOTE

In order to save a parameter to non-volatile memory, see **1009 Parameter save.**

Word 13: Value to be written

Only in case of write cycles, it includes the value to be written to the address required.

52.3.2. FROM THE SINUS PENTA TO THE MASTER

Word	1) Code	2) Description	3) Range	4) Unit of Measure	5) Scaling
1	–	Status + Alarms	–	–	–
2	M026	Output Current	0 ÷ 65000	A	x 10
3	M004	Motor Speed	– 32000 ÷ + 32000	rpm	x 1
4	–	Third measure that may be configured with P330	All the measures	See selected measure	See selected measure
5	–	Fourth measure that may be configured with P331	All the measures	See selected measure	See selected measure
6	DIN	Digital and Auxiliary Digital Inputs	–	–	–
7	DOU	Digital and Auxiliary Digital Outputs	–	–	–
8	REF	REF Analog Input (default 0÷10V)	0 ÷ 15366	–	–
9	AIN1	AIN1 Analog Input (default 4÷20mA)	1529..7652	–	–
10	AIN2	AIN2 Analog Input (default 4÷20mA)	1529..7652	–	–

The words below are significant only when using the parameter exchange memory zone to read and write all the Penta drive's parameters by referring to their Modbus address.

Word	1) Code	2) Description	3) Range	4) Unit of Measure	5) Scaling
11	Return value	Return value of the cycle required	–	–	1
12	Value	Read value	–32768 ÷ +32767	–	1

Word 1: Status + Alarms

The **Status** and **Alarms** are displayed over the fieldbus in the following format:

bit [15..8]	bit [7..0]
Status	Alarms

The **Status** codes are given in Table 139

The **Alarm** codes are given in Table 136.

Word 2: Output Current

The output current measure (**M026**) is displayed as a value that must be divided by 10 to obtain the actual motor current.

bit [15..8]	bit [7..0]
Output Current x 10	

Word 3: Motor Speed

The output motor speed (**M004**) is displayed as follows:

bit [15..8]	bit [7..0]
-------------	------------

Motor Speed

Words 4 & 5: Third & Fourth measure that may be configured with P330 & P331

Words 4 & 5 may be configured with **P330** and **P331** – more details are given in the **FIELD BUS PARAMETERS MENU**. Both words 4 & 5 are represented as follows:

bit [15..8]	bit [7..0]
Mxxx represented by P330 and P331	

Word 6: Digital and Auxiliary Digital Inputs

Digital and Auxiliary Digital input status in the word:

bit [15..8]								bit [7..0]							
XMDI8	XMDI7	XMDI6	XMDI5	XMDI4	XMDI3	XMDI2	XMDI1	MDI8	MDI7	MDI6	MDI5	MDI4	MDI3 (RESET)	MDI2	MDI1

Word 7: Digital and Auxiliary Digital Outputs

Digital and Auxiliary Digital output status in the word:

bit [15..14]	bit [13..8]						bit 7	bit 6	bit [5..4]	bit [3..0]			
	XMDO6	XMDO5	XMDO4	XMDO3	XMDO2	XMDO1		[*]		MDO4	MDO3	MDO2	MDO1/ FOUT

[*] Status of the Pre-charge contactor

Words 8, 9, 10: REF, AIN1, AIN2 Analogue Signal

Full scale values

- 0 ÷ 15366 (0 ÷ 10V input)
- -15366 ÷ 15366 (± 10V input)
- 1529 ÷ 7652 (4..20mA input)

are nominal values.

These values can be changed due to automatic compensation of the tolerance of the input stage.

bit [15..8]	bit [7..0]
REF / AIN1 / AIN2	



NOTE

The measures of the analog inputs sent from the Sinus Penta to the Master are the unfiltered measure values detected in the A/D converter output. For filtered measures, use **M037**, **M038** and **M039** respectively.

Word 11: Return value of the cycle required

The word includes the return value of the cycle required (bits):

bit [15..8]	bit 7	bit [6..0]
	1= active cycle	See table below

0	NO ANSWER
1	WAITING
2	ANSWER OK
3	ILLEGAL DATA VALUE
4	ILLEGAL ADDRESS VALUE
5	CONTROL IS ON
6	WRONG ACCESS LEVEL



7	MMI IS PROGRAMMING
---	--------------------

Word 12: Read value

The word includes the value read in case of Read cycle.

This value is to considered as legal when Word 11= 0x82 (active cycle + ANSWER OK).

53. EXPANSION BOARD CONFIGURATION MENU

53.1. Overview



NOTE

Parameters in this menu are **Rxxx** parameters. Once saved, they are active only when the drive is next switched on or when the control board is reset (by holding down the **RESET** key for more than 5 secs).

53.2. List of Parameters R021 to R023

Table 130: List of Parameters R021 to R023

Parameter	FUNCTION	User Level	MODBUS Address	DEFAULT VALUES
R021	Data Logger setting	ENGINEERING	551	Disable
R023	I/O board setting	ENGINEERING	553	None

R021 Data Logger Setting

R021	Range	1 ÷ 2	1: Disable 2: Enable
	Default	1	1: Disable
	Level	ENGINEERING	
	Address	551	
	Function	This parameter enables or disables Data Logger initialization (if the Data Logger board is fitted).	

R023 I/O Board Setting

R023	Range	0 ÷ 4	0: None 1: XMDI/O 2: XMDI/O + XAIN 3: XMDI/O + PT100 4: XMDI/O + XAIN + PT100
	Default	0	0: None
	Level	ENGINEERING	
	Address	553	
	Function	Based on the settings in the relevant parameter, this parameter enables controlling digital I/O (XMDI/O), analog inputs (XAIN) and PT100 probes located on optional control boards.	



NOTE

ES847 is required to control analog inputs (XAIN) and PT100 probes. Either ES847 or ES870 can be used to control digital I/O (XMDI/O).

54. PROFIDRIVE BOARD CONFIGURATION MENU

54.1. Overview

This menu allows programming the PROFIdrive expansion board. It can be viewed only if the PROFIdrive board is connected to the control board.



NOTE

Parameters in this menu are **Rxxx** parameters. Once changed and saved, they become active only when the drive is next switched on or when its control board is reset by holding down the **RESET** key for more than 5 secs.



NOTE

For the correct operation of the PROFIdrive board, please refer to the Sinus Penta's Motor Drives Accessories - User Manual and to the PROFIdrive COMMUNICATIONS BOARD - Installation and Programming Guide.



NOTE

If the PROFIdrive option is present, parameter **C149 START Input** must be assigned to value 1: MDI1.



NOTE

If the PROFIdrive option is fitted, alarm **A070** is allocated to bit 11 of the Control Word. **A070** trips if parameter **R016** is > 0 and bit 11 is set to 0 for a time longer than the time set in **R016**. See FIELDBUS CONFIGURATION MENU.

54.2. List of Parameters R025 to R045

Table 131: List of Parameters R025 to R045

Parameter	FUNCTION	User Level	MODBUS Address	DEFAULT VALUES
R025	Slave address	ENGINEERING	547	1
R026	PZD3 OUT	ENGINEERING	548	1: DIGITAL INPUTS
R027	PZD4 OUT	ENGINEERING	549	0: NOT USED
R028	PZD5 OUT	ENGINEERING	550	0: NOT USED
R029	PZD6 OUT	ENGINEERING	554	0: NOT USED
R030	PZD7 OUT	ENGINEERING	555	0: NOT USED
R031	PZD8 OUT	ENGINEERING	556	0: NOT USED
R032	PZD9 OUT	ENGINEERING	557	0: NOT USED
R033	PZD10 OUT	ENGINEERING	558	0: NOT USED
R034	PZD3 IN	ENGINEERING	559	0: NOT USED
R035	PZD4 IN	ENGINEERING	581	0: NOT USED
R036	PZD5 IN	ENGINEERING	582	0: NOT USED
R037	PZD6 IN	ENGINEERING	583	0: NOT USED
R038	PZD7 IN	ENGINEERING	584	0: NOT USED
R039	PZD8 IN	ENGINEERING	585	0: NOT USED
R040	PZD9 IN	ENGINEERING	586	0: NOT USED
R041	PZD10 IN	ENGINEERING	587	0: NOT USED
R044	Drive Profile Communication Mode	ENGINEERING	520	0: DP V0
R045	Drive Profile Selection	ENGINEERING	521	1: VENDOR SPECIFIC 1

R025 SLAVE ADDRESS

R025	Range	0 ÷ 126	0 ÷ 126
	Default	1	1
	Level	ENGINEERING	
	Address	547	
	Function	This parameter sets the address for the PROFIdrive board.	



NOTE

The programmed value has effect only if the board address selectors are set to zero (see the Sinus Penta's Motor Drives Accessories - User Manual and the PROFIdrive comms board User Manual).

R026 to R033 PZD3(/10) OUT

R026 to R033	Range	0 ÷ 6	0: NOT USED 1: DIGITAL INPUTS 2: AUXILIARY DIGITAL INPUTS (I/O expansion board) 3: DIGITAL OUTPUT COMMANDS 4: TORQUE REFERENCE 5: PID REFERENCE 6: PID FEEDBACK
	Default	1	1: DIGITAL INPUTS
	Level	ENGINEERING	
	Address	548 ÷ 550 // 554 ÷ 558	
	Function	These parameters allow selecting the inputs to be downloaded from the Master PLC to the drive through the eight process data items that can be mapped in the fast communication area between the Master and the Slave station.	

R034 to R041 PZD3(/10) IN

R034 to R041	Range	0 ÷ 93	See MEASURES MENU and Table 60
	Default	0	0: NOT USED
	Level	ENGINEERING	
	Address	559 // 581 ÷ 587	
	Function	These parameters allow selecting the measures to be passed to the drive from the Master PLC through the eight process data items that can be mapped in the fast communication area between the Master and the Slave station. You can select any measure from the MEASURES MENU.	

R044 DRIVE PROFILE COMMUNICATION MODE

R044	Range	0 ÷ 1	0: DP V0 1: DP V1
	Default	0	0: DP V0
	Level	ENGINEERING	
	Address	520	
	Function	This parameter sets the version of the PROFIdrive protocol.	

R045 DRIVE PROFILE SELECTION

R045	Range	0 ÷ 2	0: PROFIDRIVE 1: VENDOR SPECIFIC 1 2: VENDOR SPECIFIC 2	
	Default	1	1: VENDOR SPECIFIC 1	
	Level	ENGINEERING		
	Address	507		
	Function	This parameter sets the control mode (Command and Reference) for the Slave station. 0: PROFIDRIVE 1: VENDOR SPECIFIC 1 2: VENDOR SPECIFIC 2		
			Command	Reference
	PROFIDRIVE	According to the PROFIdrive protocol.	According to the PROFIdrive protocol.	
	VENDOR SPECIFIC 1	According to the PROFIdrive protocol.	One-to-one scale of the programmed reference.	
	VENDOR SPECIFIC 2	The eight low bits in the CONTROL WORD represent the eight digital inputs in the control board.	One-to-one scale of the programmed reference.	



NOTE

Bit 11 in the control board enables or not the Fieldbus line watchdog in any of the three control modes above, provided that parameter **R016** is set higher than zero.



NOTE

The watchdog activates only after the drive has received the first legal message sent from the master (see Alarm A070 (Communication Suspended), thus preventing alarm **A070** from tripping due to different power-on times between the master station and the Penta drive.

55. DAYLIGHT SAVING TIME

55.1. Overview



NOTE

The Daylight Saving Time menu may be accessed only if the Data Logger board is installed (even the ES851 RTC version only) and if parameter **R021** Data Logger setting is set to 2: ENABLE.

Parameters **R050** to **R053** set the DST rules for the Clock/Calendar of the Data Logger or the ES851 RTC. See DATE AND TIME MENU.



NOTE

By setting parameters **R050** and **R052** to 0, the DST is not managed.

55.2. List of Parameters R050 to R053

Table 132: List of Parameters R050 to R053

Parameter	FUNCTION	User Level	DEFAULT VALUES	MODBUS Address
R050	DST Start WDMM	ENGINEERING	5703	524
R051	DST Start HHMM	ENGINEERING	200	525
R052	DST End WDMM	ENGINEERING	5710	526
R053	DST End HHMM	ENGINEERING	200	527

R050 DST Start WDMM – Week/Day/Month

R050	Range	0 ÷ 9112	0 ÷ 9112
	Default	5703	5703
	Level	ENGINEERING	
	Active	This parameter can be viewed and changed only if the Data Logger ES851 is installed and activated (R021 = ENABLE).	
	Address	524	
	Function	<p>If the first digit of the parameter is lower than 6: The first digit (W) indicates the week of the month when the DST starts (1 = first week, 2 = second week, 3 = third week, 4 = fourth week, 5 = last week). The second digit (D) indicates the day of the week (1 = Monday, 7 = Sunday). The third and fourth digits (MM) indicate the start month (01 = January, 12 = December). Example: European Union: 5703 (last Sunday in March) USA: 2703 (second Sunday in March) Brazil: 3710 (third Sunday in October)</p> <p>If the first digit of the parameter is higher than or equal to 6: The first two digits (WD) correspond to the day of the month when the DST starts, added to 60 (61 corresponds to 1, 91 corresponds to 31). The third and fourth digit (MM) indicate the start month (01 corresponds to January, 12 corresponds to December). Example: 7504 = 15 April.</p>	

R051 DST Start HHMM – Hour/Minutes

R051	Range	100 ÷ 2400	100 ÷ 2400
	Default	200	200
	Level	ENGINEERING	
	Active	This parameter can be viewed and changed only if the Data Logger ES851 is installed and activated (R021 = ENABLE).	
	Address	525	
	Function	The first digit or the first two digits (if the total digits are 3 or 4 respectively) correspond to the start hours. The last two digits correspond to the minutes. Example: 200 = 2h 00m 2400 = 0h 0m (midnight between the day set in R050 and the previous day.)	

R052 DST End WDMM – Week/Day/Month

R052	Range	0 ÷ 9112	0 ÷ 9112
	Default	5710	5710
	Level	ENGINEERING	
	Active	This parameter can be viewed and changed only if the Data Logger ES851 is installed and activated (R021 = ENABLE).	
	Address	526	
	Function	<p>If the first digit of the parameter is lower than 6: The first digit (W) indicates the week of the month when the DST ends (1 = first week, 2 = second week, 3 = third week, 4 = fourth week, 5 = last week). The second digit (D) indicates the day of the week (1 = Monday, 7 = Sunday). The third and fourth digits (MM) indicate the start month (01 = January, 12 = December). Example: European Union: 5710 (last Sunday in October) USA: 1711 (first Sunday in November) Brazil: 3702 (third Sunday in February)</p> <p>If the first digit of the parameter is higher than or equal to 6: The first two digits (WD) correspond to the day of the month when the DST starts, added to 60 (61 corresponds to 1, 91 corresponds to 31). The third and fourth digit (MM) indicate the start month (01 corresponds to January, 12 corresponds to December). Example: 6110 = 1 October.</p>	

R053 DST End HHMM – Hour/Minutes

R053	Range	100 ÷ 2400	100 ÷ 2400
	Default	200	200
	Level	ENGINEERING	
	Active	This parameter can be viewed and changed only if the Data Logger ES851 is installed and activated (R021 = ENABLE).	
	Address	527	
	Function	The first digit or the first two digits (if the total digits are 3 or 4 respectively) correspond to the end hours. The last two digits correspond to the minutes. Example: 200 = 2h 00m 2400 = 0h 0m (midnight between the day set in R052 and the previous day.)	

56. DATA LOGGER MENU

56.1. Overview

The Data Logger menu is to be used if the Penta drive cannot dialog with the Data Logger ES851 board through the RemoteDrive software.

Parameter **R116** imposes to ES851 the type of connection required for the communication mode being used.



NOTE

The Data Logger menu may be accessed only if the Data Logger board is installed and if parameter **R021** Data Logger setting is set to 2: ENABLE.

Important: The complete version of the Data Logger ES851 shall be installed (the RTC version only is not suitable for this functionality). Please refer to the Motor Drives Accessories - User Manual.



NOTE

The parameters described in this menu are **Rxxx** parameters.

Once changed and saved, they become active only when the drive is next switched on or when the control board is reset (by holding down the **RESET** key for more than 5 secs).



CAUTION

The parameters set from this menu are not saved to non-volatile memory of the Data Logger board.

They must be confirmed and saved using the RemoteDrive software.

56.2. List of Parameters R115 and R116

Table 133: List of Parameters R115 and R116

Parameter	FUNCTION	User Level	MODBUS Address	DEFAULT VALUES
R115	SIM Card PIN	BASIC	563	"0000"
R116	Preset connection status	ENGINEERING	134	0: no active preset

R115 SIM Card PIN

R115	Range	Default	Level	Address	Function
	0x0000 ÷ 0xAAAA	0x0000	BASIC	563	This parameter indicates the digits of the PIN of the SIM card fitted in the GSM/GPRS modem. The digits must be aligned left; the # symbol, which is codified as 0xA (hex) is intended as the number terminator.
		"0" ÷ "9999"			"0000"



NOTE

Max. 4 digits are allowed for the SIM card PIN.

The PIN can be composed of less than 4 digits and the # symbol can be used as the PIN terminator.

R116 Preset Connection Status (Line 2)

R116 Line 2	Range	Address	Function
	0 ÷ 20	1337	This parameter indicates if preset configurations are actually set up for the types of connections supported by ES851.
		See Table 134	

R116 Preset Connections (Line 4)

R116 Line 4	Range	0 ÷ 20	See Table 134
	Default	0	0: no active preset
	Level	ENGINEERING	
	Address	134	
	Function	This parameter allows forcing one of the available connecting modes to the Data Logger ES851 board. The parameters used for Ethernet connections and modem connections are the ones stored in the Penta drive. Configurations 19 and 20 support both dial in and dial out.	



NOTE

After imposing any of the preset values given in Table 134, the Data Logger is forced to Interlocked mode (see the Data Logger Measures Menu).

Table 134: Preset connections

Value	COM	Baudrate [bps]	Stop bit	Parity	Delay [ms]
0	No active presetting				
1	Ethernet enabled				
2	PPP null modem				
3	1(RS232)	38400	2	no	2
4	1(RS232)	38400	1	no	2
5	1(RS232)	38400	2	no	20
6	1(RS232)	38400	1	no	20
7	1(RS232)	9600	2	no	2
8	1(RS232)	9600	1	no	2
9	1(RS232)	9600	2	no	20
10	1(RS232)	9600	1	no	20
11	2(RS485)	38400	2	no	2
12	2(RS485)	38400	1	no	2
13	2(RS485)	38400	2	no	20
14	2(RS485)	38400	1	no	20
15	2(RS485)	9600	2	no	2
16	2(RS485)	9600	1	no	2
17	2(RS485)	9600	2	no	20
18	2(RS485)	9600	1	no	20
19	Dial Out analog modem				
20	Dial Out GSM modem				

57. EEPROM MENU

57.1. Overview

The drive has four different memory areas:

- **RAM** → Volatile memory containing the drive's current parameterization;
- **DEFAULT Area** → Non-volatile memory that cannot be accessed by the user, containing the factory-setting of the drive parameters.
- **WORK Area** → Non-volatile memory where customized parameters are saved. Whenever the drive is reset, this parameterization is loaded to the RAM.
- **BACKUP Area** → Non-volatile memory storing a new drive parameterization. Back-up parameters are modified only when the user explicitly saves the BACKUP Area.

Any parameter can be changed by the user. The drive will immediately use the new parameter value.

The user may save the parameter value in the Work area. If no new value is saved for a given parameter, the drive will use the parameter value stored in the Work area when next turned on.

- “P” parameters can be written at any moment.
- According to factory-setting, “C” parameters may be written when the equipment is on stand-by or when the motor is not running and the equipment is fluxing. See **P003** to modify them only when the **ENABLE-A** and **ENABLE-B** commands are deactivated (terminal **MDI2** open).
- “R” parameters have the same features as “C” parameters, but the new parameter value, once written and saved, will be used only at next power on. To use the new parameter value immediately, turn the drive off and on or press the **RESET** key for at least 5 seconds.

The WORK area may be copied to the BACKUP area through **I012** included in this menu and described in the section below.

I012 input also allows copying the BACKUP area to the WORK area in order to restore the parameter values stored in the WORK area.

I012 input also allows restoring the factory-setting values for all parameters in the WORK area.

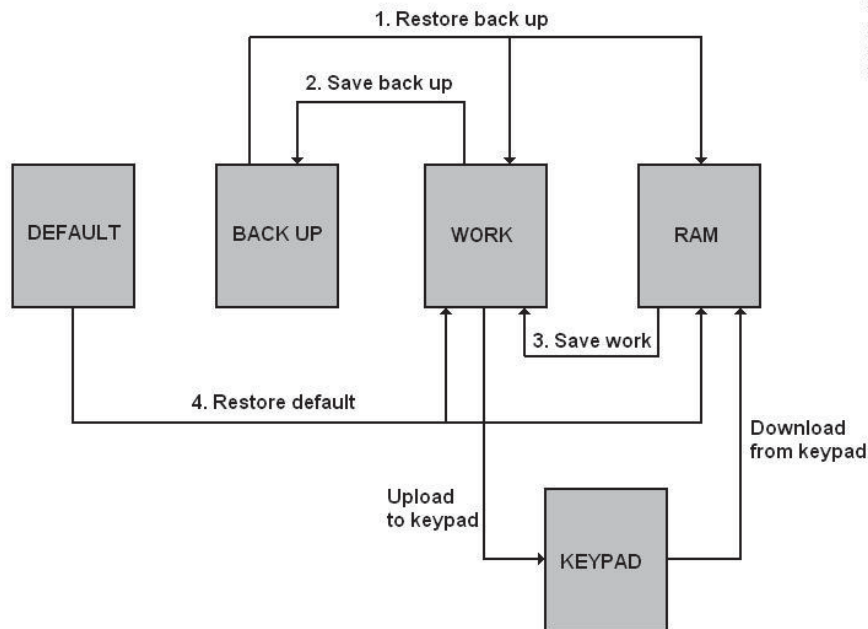

S000443

57.2. List of Inputs I009 to I013

Table 135: List of Inputs I009 to I013

Input	FUNCTION	User Level	MODBUS Address
I009	Parameter save	BASIC	1396
I012	EEPROM control	BASIC	1399
I013	Alarm control	BASIC	1400

I009 Parameter save

I009	Range	131 ÷ 2466	131 ÷ 2466
	Default	This is not a parameter: at power on and whenever the command is executed, I009 is set to zero.	
	Level	BASIC	
	Address	1396	
	Function	Allows only one parameter to be saved to EEPROM. The value to be saved must be the same as the value set in the Address field of the parameter concerned.	

I012 EEPROM Control

I012	Range	0, 2, 4, 5, 11	0: No Command 2: Restore Backup 4: Save Backup 5: Save Work 11: Restore Default
	Default	This is not a parameter: at power on and whenever the command is executed, I012 is set to zero.	
	Level	BASIC	
	Address	1399	
	Function	<p>This parameter saves and restores the entire set of parameters that can be accessed by the user:</p> <p>2: Restore Backup: the parameters stored in the BACKUP area are copied and stored in the WORK area. They represent the new RAM parameterization; the previous RAM parameters are cleared. BACKUP → RAM → WORK;</p> <p>4: Save Backup: the parameters in the WORK zone are saved to a copy of the BACKUP area. WORK → BACKUP;</p> <p>5: Save Backup: the current values of the parameters stored in the RAM area are saved to non-volatile memory in the WORK area. All the parameters are saved with this command. RAM → WORK;</p> <p>11: Restore Default: factory-setting values are restored for all parameters; each factory-setting value is stored to non-volatile memory in the WORK area. DEFAULT → RAM → WORK.</p>	

I013 Alarm Control

I013	Range	1, 777	1: Trips alarm A040 777: Resets the alarms tripped
	Default	This is not a programming parameter: the input is set to zero whenever the drive is powered on and whenever the command is executed.	
	Level	BASIC	
	Address	1400	
	Function	1: Trips alarm A040 (User alarm). It may be helpful to test the system. 777: Resets the alarms tripped. Resets any alarm tripped (not only A040).	

58. ALARMS AND WARNINGS

CAUTION

If a protection trips or the drive enters the emergency mode, the drive is locked and the motor starts idling!

58.1. What Happens When a Protection Trips

NOTE

Before operating the drive in emergency conditions, carefully read this section and the following section What To Do When an Alarm Trips.

The drive alarms are detailed below.

When a protection / alarm trips:

- 1) the **ALARM** LED on the keypad comes on;
- 2) the page displayed on the keypad is the root page of the **FAULT LIST**;
- 3) the **FAULT LIST** is refreshed;
- 4) when using the Drive Profile board, the drive reports faults as hexadecimal values, which are assigned and coded according to the DRIVECOM specification. See Table 139.

In factory-setting, when the drive is switched on after an alarm has tripped—which has not been reset—it is kept in emergency condition.

If the drive is in emergency mode when switched on, this could be due to an alarm tripped before the drive was reset.

To avoid storing the alarms tripped before the drive is switched off, set parameter **C257** in the **Autoreset Menu**.

The drive stores the moment when an alarm trips to the **FAULT LIST** (supply-time and operation-time). The drive status when the alarm tripped and some measures sampled when the alarm tripped are also stored to the Fault List.

The readout and storage of the fault list can be very useful to detect the cause responsible for the alarm and its possible solution (see also the Fault List Menu).

NOTE

Alarms **A001** to **A039** relate to the main microcontroller (DSP Motorola) of the control board, which detected a fault on the control board itself. No fault list is available for Alarms **A001** to **A039** and no Reset command can be sent via serial link; alarms can be reset through the **RESET** terminal on the terminal board or the **RESET** key on the keypad. No software for the keypad interface is available; the drive parameters and measures cannot be accessed via serial link.

Avoid resetting alarms **A033** and **A039**, as they trip when the flash memory is not provided with its correct software. Alarms **A033** and **A039** can be reset only when proper software is downloaded for the the inverter flash memory.

CAUTION

Before resetting an alarm, deactivate the **ENABLE-A** and **ENABLE-B** signals on terminal **MD12** to disable the inverter and prevent the connected motor from running at uncontrolled speed, unless parameter **C181**=1 (the Safety Start function is active): after resetting an alarm or after supplying the inverter, this will start only if the **ENABLE-A** and **ENABLE-B** contacts are opened and closed again.

58.2. What To Do When an Alarm Trips



CAUTION

If a protection trips or the drive is in emergency condition, the drive is locked and the motor starts idling!



CAUTION

Before resetting an alarm, disable the **ENABLE-A** and **ENABLE-B** signals on terminal **MDI2** to disable the drive and to prevent the connected motor from running at uncontrolled speed.

Proceed as follows:

1. Disable the **ENABLE-A** and **ENABLE-B** signals on terminal **MDI2** to disable the drive and to lock the motor, unless parameter **C181=1** (the Safety Start function is active): after resetting an alarm or after supplying the drive, this will start only if the **ENABLE-A** and **ENABLE-B** contacts are open and closed.
2. If the motor is idling, wait until it stops.

Check the **FAULT LIST** carefully for any information about the alarm tripped, in order to determine the cause responsible for the alarm and its possible solutions.

Any information stored to the FAULT LIST is also required when contacting Brammer's Customer Service.

3. In the following sections, find the relative alarm code and follow the instructions.
4. Solve any external problems that may have been responsible for the protection trip.
5. If the alarm tripped due to the entry of wrong parameter values, set new correct values and save them.
6. Reset the alarm.
7. If the alarm condition persists, please contact Brammer Customer Service.

A **RESET** command must be sent to reset the alarms tripped. Do one of the following:

- Enable the **RESET** signal in **MDI3** terminal in the hardware terminal board;
- Press the **RESET** key on the keypad;
- Enable the **RESET MDI3** signal in one of the virtual terminal boards enabled as remote command sources (see the CONTROL METHOD MENU).

To activate the **Autoreset** function, enable parameter **C255** (see the AUTORESET MENU); the drive will automatically try to reset the alarms tripped.

58.3. Alarm List

Table 136: List of the possible alarms

Alarm	Alarm Message	Description
A001 ÷ A032	...	<i>Control board failure</i>
A033	TEXAS VER KO	Incompatible Texas Software Version
A039	FLASH KO	Texas Flash not programmed
A040	User Fault	Alarm caused by the user
A041	PWMA Fault	General hardware fault from IGBT
A042	Illegal XMDI in DGI	Illegal configuration of XMDI in the Digital Inputs menu
A043	False Interrupt	<i>Control board failure</i>
A044	SW OverCurrent	Software overcurrent
A045	Bypass Circuit Fault	Fault of the precharge By-Pass
A046	Bypass Connector Fault	Precharge By-Pass connector fault
A047	UnderVoltage	Dc bus voltage lower than Vdc_min
A048	OverVoltage	Dc bus voltage exceeding Vdc_max
A049	RAM Fault	<i>Control board failure</i>
A050	PWMA0 Fault	Hardware Fault from IGBT converter
A051	PWMA1 Fault	Hardware overcurrent
A052	Illegal XMDI in DGO	Illegal configuration of XMDI in the Digital Outputs menu
A053	PWMA Not ON	Hardware failure, IGBT A power on impossible
A054	Optional Board not in	Failure in detecting preset optional I/O board
A055	PTC Alarm	External PTC tripped
A056	PTC Short Circuit	External PTC in short circuit
A057	Illegal XMDI in MPL	Illegal configuration of XMDI in the Virtual Digital Outputs (MPL) menu
A059	Encoder Fault	Error of motor speed measure
A060	NoCurrent Fault	Current is zero in FOC control
A061	Ser WatchDog	Watchdog tripped in serial link 0 (9-pole D connector)
A062	SR1 WatchDog	Watchdog tripped in serial link 1 (RJ45)
A063	Generic Motorola	<i>Control board failure</i>
A064	Mains Loss	No power is supplied from the mains
A065	AutoTune Fault	Autotune failed
A066	REF < 4mA	REF Current input (4÷20mA) lower than 4mA
A067	AIN1 < 4mA	AIN1 Current input (4÷20mA) lower than 4mA
A068	AIN2 < 4mA	AIN2 Current input (4÷20mA) lower than 4mA
A069	XAIN5 < 4mA	XAIN5 Current input (4÷20mA) lower than 4mA
A070	Fbs WatchDog	Fieldbus Watchdog tripped
A071	1ms Interrupt OverTime	<i>Control board failure</i>
A072	Parm Lost Chk	Parameter download/upload error
A073	Parm Lost COM1	Parameter download/upload error
A074	Drive OverHeated	Drive thermal protection tripped
A075	Motor OverHeated	Motor thermal protection tripped
A076	Speed Alarm	Motor speed too high
A078	MMI Trouble	<i>Control board failure</i>
A079	Encoder not conf.	FOC control but Encoder not properly configured
A080	Tracking Error	Encoder speed tracking error
A081	KeyPad WatchDog	Communication watchdog via keypad
A082	Illegal Encoder Cfg	Functions programmed for MDI6 and MDI7 or encoder B selected and encoder board not detected.
A083	External Alarm 1	External alarm 1
A084	External Alarm 2	External alarm 2
A085	External Alarm 3	External alarm 3
A086	XAIN5 > 20mA	XAIN5 Current input (4÷20mA or 0÷20mA) greater than 20mA
A087	±15V LOSS	± 15V Loss
A088	ADC Not Tuned	<i>Control board failure</i>
A089	Parm Lost COM2	Parameter download/upload error
A090	Parm Lost COM3	Parameter download/upload error

A091	Braking Resistor Overload	Overvoltage tripped with braking resistor activated due to continuous operation time exceeding the max. programmed time
-------------	---------------------------	---



Alarm	Alarm Message	Description
A092	SW Version KO	Control board failure
A093	Bypass Circuit Open	By-Pass relay open
A094	HeatSink Overheated	IGBT heatsink temperature too high
A095	Illegal Drive Profile Board	Drive Profile board not correctly configured
A096	Fan Fault	Fault of the cooling fans
A097	Motor Not Connected	Motor not connected
A098	Illegal Motor Selected	Illegal motor selected via MDI
A099	2nd Sensor Fault	Fault of fan sensor 2
A100	MDI6 Illegal Configuration	Function programmed for MDI6 along with frequency input A
A101	MDI8 Illegal Configuration	Function programmed for MDI8 along with frequency input B
A102	REF > 20mA	REF Current input (4÷20mA or 0÷20mA) greater than 20mA
A103	AIN1 > 20mA	AIN1 Current input (4÷20mA or 0÷20mA) greater than 20mA
A104	AIN2 > 20mA	AIN2 Current input (4÷20mA or 0÷20mA) greater than 20mA
A105	PT100 Channel 1 Fault	Hardware address out of measure range of the drive
A106	PT100 Channel 2 Fault	Hardware address out of measure range of the drive
A107	PT100 Channel 3 Fault	Hardware address out of measure range of the drive
A108	PT100 Channel 4 Fault	Hardware address out of measure range of the drive
A109	Amb.Overtemp.	Ambient overtemperature
A110	Fieldbus Board Fault	Fault occurring in the Fieldbus board
A111 ÷ A120	...	Control board failure
A129	No Output Phase	Output phase loss
A140	Torque Off not Safe	Malfunctioning of ENABLE-A and ENABLE-B inputs for STO function
A141	Illegal Hardware	SW version incompatible with the drive hardware

A001 ÷ A032, A043, A049, A063, A071, A078, A088, A092, A111÷A120 Control Board Failure

A001 ÷ A032 A043 A049 A063 A071 A078 A088 A092 A111 ÷ A120	Description	Control board failure
	Event	There may be several causes: the board autodiagnosics file constantly checks its operating conditions.
	Possible cause	<ul style="list-style-type: none"> • Strong electromagnetic disturbance or radiated interference. • Possible failure of the microcontroller or other circuits on the control board.
	Solution	1. Reset the alarm: send a RESET command. 2. If the alarm persists, please contact BRAMMER's Customer Service.

A033 Texas Software KO

A033	Description	Incompatible Software Texas version
	Event	When switched on, DSP Motorola detected an incompatible version of the software downloaded to Flash Texas (software version incompatible with Motorola).
	Possible cause	The wrong software was downloaded.
	Solution	1. Download the correct DSP Texas software version. 2. If the alarm persists, please contact BRAMMER's Customer Service.

A039 Texas Flash not Programmed

A039	Description	Texas Flash not programmed
	Event	When switched on, DSP Motorola detected that Flash Texas is not correctly programmed.
	Possible cause	A prior attempt to download DSP Texas software failed.
	Solution	1. Download the correct DSP Texas software version. 2. If the alarm persists, please contact BRAMMER's Customer Service.

A040 User Alarm

A040	Description	Alarm trip caused by the user (as a system testing procedure)
	Event	The user has forced the alarm to trip.
	Possible cause	Value 1 was entered to address MODBUS 1400 via serial link.
	Solution	Reset the alarm: send a RESET command.

A041 IGBT Fault Side A

A041	Description	General hardware fault from IGBT
	Event	Power converter generated a general alarm.
	Possible cause	<ul style="list-style-type: none"> • Electromagnetic disturbance or radiated interference. • Overcurrent, IGBT overtemperature, IGBT fault.
	Solution	1. Reset the alarm: send a RESET command. 2. If the alarm persists, please contact BRAMMER's Customer Service.

A042 Illegal XMDI in DGI

A042	Description	Illegal configuration of XMDI in the Digital Inputs menu.
	Event	<ul style="list-style-type: none"> • The drive checked if at least one XMDI input from ES847 or ES870 I/O optional board is available in the DIGITAL INPUTS MENU; • The drive checked if R023 (I/O Board setting) is set to 0 in the EXPANSION BOARD CONFIGURATION MENU
	Possible cause	Wrong settings.
	Solution	Check settings and enter correct settings.

A044 SW Overcurrent

A044	Description	SW Overcurrent
	Event	Immediate current limit tripped
	Possible cause	<ul style="list-style-type: none"> Abrupt variations of the connected load Output short-circuit or ground short-circuit Strong electromagnetic disturbance or radiated interference. <p>If alarm A044 tripped while accelerating:</p> <ul style="list-style-type: none"> Too short acceleration ramp; <p>If alarm A044 tripped while decelerating:</p> <ul style="list-style-type: none"> Too short deceleration ramp. Excessive gain of the current regulator (P155) or too short integral time (P156) when using the FOC control algorithm. Excessive gain of the speed regulator (P128) or too short integral time (P126) when using the VTC control algorithm.
	Solution	<ol style="list-style-type: none"> 1. Check if the drive and the motor are properly dimensioned with respect to the connected load. 2. Make sure that no output short-circuit is to be found between two phases or between one phase and the grounding (terminals U, V, W). (Remove voltage from the motor, set IFD control and operate the drive in no-load conditions.) 3. Check if the command signals are sent to the drive using screened cables where required (see Sinus Penta's Installation Guide). Detect external sources for electromagnetic disturbance, check wiring and make sure that antidisturbance filters are installed on the coils of contactors and electrovalves (if fitted inside the cabinet). 4. If necessary, set longer acceleration times (see the RAMPS MENU). 5. If necessary, set longer deceleration times (see the RAMPS MENU). 6. If necessary, decrease the values set in the LIMITS MENU.

A045 Bypass Circuit Fault

A045	Description	Bypass precharge Fault
	Event	The drive forced to close its relay or contactor for the short-circuit of the precharge resistors in DC-link capacitors (DC bus), but it <u>did not detect the relevant closing signal</u> while precharging. See also A046 .
	Possible cause	<ul style="list-style-type: none"> Disconnection of auxiliary signal. Precharge relay/contactor failure.
	Solution	<ol style="list-style-type: none"> 1. Reset the alarm: send a RESET command. 2. If the alarm persists, please contact BRAMMER's Customer Service.

A046 Bypass Connector Fault

A046	Description	Precharge bypass connector fault.
	Event	Auxiliary signal for the closing of the bypass connector of the short-circuit precharge resistor is considered as closed before the relevant closing command is sent. See also A045 .
	Possible cause	<ul style="list-style-type: none"> Precharge bypass connector reversed. Precharge relay/contactor failure.
	Solution	<ol style="list-style-type: none"> 1. Reset the alarm: send a RESET command. 2. If the alarm persists, please contact BRAMMER's Customer Service.

A047 Undervoltage

A047	Description	DC bus Voltage lower than minimum voltage.
	Event	Voltage measured in DC bus capacitors has dropped below the min. value allowed for a proper operation of the drive class being used.
	Possible cause	<ul style="list-style-type: none"> Supply voltage has dropped below 200Vac-15% (class 2T), 380V-15% (class 4T), 500V -15% (class 5T), 600Vac -5% (class 6T). Alarm A047 can trip even when voltage temporarily drops below the allowable min. value (which is caused for example by the direct starting of the connected load). If the drive is powered directly by the bus bar, the bus feeder is responsible for the alarm. Failure in DC bus voltage measure circuit.
	Solution	<ol style="list-style-type: none"> 1. Check voltage in terminals R, S, T. Check mains voltage value M030 and DC bus voltage value M029. Also check the values of M030 and M029 sampled in the FAULT LIST when the alarm tripped. 2. If the alarm persists, please contact BRAMMER's Customer Service.

A048 Overvoltage

A048	Description	Overvoltage in DC bus (voltage in DC-link).
	Event	Voltage measured in DC bus (DC-link) capacitors has exceeded the max. value allowed for a proper operation of the drive class being used.
	Possible cause	<ul style="list-style-type: none"> • Check that voltage does not exceed 240Vac +10% (class 2T), 500Vac +10% (class 4T), 600Vac +10% (class 5T), 690Vac +10% (class 6T). • Very inertial loads and a too short deceleration ramp (see the RAMPS MENU). • Alarm A048 can trip even when the motor is pulled by the load (eccentric load). • If the drive is powered directly by the bus bar, the bus feeder is responsible for the alarm trip. • Failure in DC bus voltage measure circuit.
	Solution	<ol style="list-style-type: none"> 1. Check voltage in terminals R, S, T. Check mains voltage value M030 and DC bus voltage value M029. Also check the values of M030 and M029 sampled in the FAULT LIST when the alarm tripped. 2. In case of very inertial loads and if the alarm tripped when decelerating, try to set a longer deceleration ramp. If short stop times are needed or if the motor is pulled by the load, activate the resistive braking unit. 3. If the alarm persists, please contact BRAMMER's Customer Service.

A050 IGBT Fault A

A050	Description	Hardware fault from IGBT converter or brake overcurrent
	Event	The IGBT drivers of power converter have detected IGBT failure or overcurrent conditions in the brake circuit (models S14, S22, S32 5T/6T only)
	Possible cause	<ul style="list-style-type: none"> • Strong electromagnetic disturbance or radiated interference. • Overcurrent, IGBT overtemperature, IGBT fault. • Unsuitable braking resistor (models S14, S22, S32 5T/6T only).
	Solution	<ol style="list-style-type: none"> 1. Reset the alarm: send a RESET command. 2. If the alarm persists, please contact BRAMMER's Customer Service.

A051 Overcurrent HW A

A051	Description	Hardware overcurrent
	Event	Hardware overcurrent detected by the drive output current circuit.
	Possible cause	See A044 SW Overcurrent .
	Solution	See A044 SW Overcurrent .

A052 Illegal XMDI in DGO

A052	Description	Illegal configuration of XMDI in the Digital Outputs menu.
	Event	<ul style="list-style-type: none"> The drive checked if at least one XMDI input from ES847 or ES870 I/O optional board is available in the DIGITAL INPUTS MENU; The drive checked if R023 (I/O Board setting) is set to 0 in the EXPANSION BOARD CONFIGURATION MENU
	Possible cause	Wrong settings.
	Solution	Check settings and enter correct settings.

A053 Not PWONA

A053	Description	Hardware failure; IGBT A power on failure.
	Event	IGBT A power on controlled by Motorola microcontroller has failed.
	Possible cause	Control board failure.
	Solution	<ol style="list-style-type: none"> Reset the alarm: send a RESET command. If the alarm persists, please contact BRAMMER's Customer Service.

A054 Optional Board not in

A054	Description	ES847 or ES870 not in.
	Event	The control board detects no ES847 or ES870 I/O expansion boards after parameter R023 (I/O Board Setting) is set as $\neq 0$.
	Possible cause	Optional board not in or faulty.
	Solution	<ol style="list-style-type: none"> Check consistency of parameter R023 (see the EXPANSION BOARD CONFIGURATION MENU). Reset the alarm: send a RESET command. If the alarm persists, please contact BRAMMER's Customer Service.

A055 PTC Alarm

A055	Description	External PTC resistor tripped.
	Event	The drive detected the opening of the PTC connected to AIN2 input (R > 3600 ohm)
	Possible cause	<ul style="list-style-type: none"> Opening of the PTC due to motor overheating. Incorrect wiring of PTC. Incorrect setting of SW1 hardware switch on the control board (see Installation Guide).
	Solution	<ol style="list-style-type: none"> Allow the motor to cool, then reset the alarm. Make sure that the PTC is correctly connected to AIN2 analog input (see Installation Guide). Make sure that SW1 hardware switch is correctly set.

A056 PTC Short Circuit

A056	Description	External PTC resistor short circuit.
	Event	Detected the short circuit of the PTC connected to AIN2 input ($R < 10$ ohm).
	Possible cause	<ul style="list-style-type: none"> • Short circuit in the PTC. • Incorrect wiring of PTC. • Incorrect setting of SW1 hardware switch on the control board (see Installation Guide).
	Solution	<ol style="list-style-type: none"> 1. Make sure that the PTC is correctly connected to AIN2 analog input (see Installation Guide). 2. Make sure that SW1 hardware switch is correctly set.

A057 Illegal XMDI in MPL

A057	Description	Illegal configuration of XMDI in the Virtual Digital Outputs (MPL) Menu.
	Event	<ul style="list-style-type: none"> • The drive checked if at least one XMDI input from ES847 or ES870 I/O optional board is available in the VIRTUAL DIGITAL OUTPUTS (MPL) MENU; • The drive checked if R023 (I/O Board setting) is set to 0 in the EXPANSION BOARD CONFIGURATION MENU
	Possible cause	Wrong settings.
	Solution	Check settings and enter correct settings.

A059 Encoder Fault

A059	Description	Motor speed measure error.
	Event	During the encoder tune, a speed error measure occurred with respect to the estimated speed, although the sign of the measured speed is consistent with the estimated speed.
	Possible cause	<ul style="list-style-type: none"> • Incorrect parameterization of the encoder concerning the type and number of pulses/rev. • Voltage removed from one of the two encoders. • Incorrect mounting of the encoders. • Encoder failure.
	Solution	<ol style="list-style-type: none"> 1. Check that the encoder parameters are correct (see the ENCODER/FREQUENCY INPUTS MENU). 2. Check that both encoders are properly connected. 3. Check mounting of the encoders. 4. Using an oscilloscope, check that the encoder signals are correct.

A060 No Current Fault (FOC)

A060	Description	The error detected in FOC control by the current loop exceeds the max. allowable value.
	Event	The FOC control detected a current regulation error.
	Possible cause	<ul style="list-style-type: none"> One motor cable is disconnected. Failure in the current measure circuit. Wrong setting of current regulator parameters for FOC control.
	Solution	<ol style="list-style-type: none"> 1. Check motor connections (terminals U, V, W). 2. Check parameterization of current regulators for FOC control (see the FOC REGULATORS MENU). Perform a new current regulator autotune (see AUTOTUNE MENU). 3. If the alarm persists, please contact BRAMMER's Customer Service.

A061, A062 Serial Link Watchdog

A061 (Serial Link 0) A062 (Serial Link 1)	Description	A061: Serial Link Watchdog 0 tripped A062: Serial Link Watchdog 1 tripped
	Event	<p>The serial link watchdog has tripped.</p> <p>Communication failure: no read/write query sent to serial link for a time longer than the time set in the parameters relating to serial link watchdog (see the SERIAL LINKS MENU).</p> <p>This alarm does not trip if, due to parameters in the CONTROL METHOD MENU or due to the status of the source selection or LOC/REM inputs (DIGITAL INPUTS MENU), the information sent from serial link is not currently used for the commands or the references.</p>
	Possible cause	<ul style="list-style-type: none"> Serial link is disconnected. Communication failure on remote master side. Watchdog operating times too short.
	Solution	<ol style="list-style-type: none"> 1. Check serial link. 2. Make sure that the remote master constantly sends read/write queries with max. intervals between two queries lower than the preset watchdog operating time. 3. Set longer watchdog operating times (see R005 for serial link 0 and R012 for serial link 1).

A064 Mains Loss

A064	Description	Mains loss
	Event	Mains loss.
	Possible cause	<ul style="list-style-type: none"> One supply cable is disconnected. Mains supply too weak. Mains gap.
	Solution	<ol style="list-style-type: none"> 1. Check voltage in terminals R, S, T. Check mains voltage value M030. Also check the value of M030 sampled in the FAULT LIST when the alarm tripped. 2. This protection may be disabled or delayed (see the POWER DOWN MENU).

A065 Autotune KO

A065	Description	Autotune failed.
	Event	Autotune aborted or failed.
	Possible cause	<ul style="list-style-type: none"> The ENABLE contact was disabled before autotune was over. Autotune aborted, maybe because the parameter values were inconsistent with the motor ratings.
	Solution	<ol style="list-style-type: none"> 1. Reset the alarm: send a RESET command. 2. Check the motor parameters and make sure that they are consistent with the motor ratings (see the MOTOR CONFIGURATION MENU) and perform a new autotune procedure. 3. If the alarm persists, please contact BRAMMER's Customer Service.

A066, A067, A068, A069 Current input < 4mA

A066 (REF) A067 (AIN1) A068 (AIN2) A069 (XAIN5)	Description	A066: REF Current input (4÷20mA) lower than 4mA A067: AIN1 Current input (4÷20mA) lower than 4mA A068: AIN2 Current input (4÷20mA) lower than 4mA A069: XAIN5 current input (4÷20mA) lower than 4mA
	Event	A current value lower than 4 mA has been detected over one input (REF, AIN1, AIN2, XAIN5) set with the following range: 4÷20mA.
	Possible cause	<ul style="list-style-type: none"> Wrong setting of SW1 on the control board (except for A069). Signal cable disconnected. Failure in the current signal source.
	Solution	<ol style="list-style-type: none"> 1. Check setting of SW1 (except for A069). 2. Check that the signal cable is properly connected to its terminal. 3. Check the current signal source.



NOTE The alarms above trip only if the relevant inputs have been selected (see CONTROL METHOD MENU and PID CONFIGURATION MENU).

A070 Fieldbus WatchDog

A070	Description	Watchdog Fieldbus tripped.
	Event	The watchdog fieldbus tripped and communication is suspended. Communication is interrupted: the Master did not send any valid message for a time longer than the time set in the parameter relating to the value set with parameter R016 of the fieldbus watchdog time (see the FIELDBUS CONFIGURATION MENU). This alarm does not trip if, due to parameters in the CONTROL METHOD MENU or due to the status of the source selection or LOC/REM inputs (DIGITAL INPUTS MENU), the information sent from fieldbus is not currently used for the commands or the references.
	Possible cause	<ul style="list-style-type: none"> Voltage removed from Fieldbus. No communication from Master. Watchdog times too short.
	Solution	<ol style="list-style-type: none"> 1. Check fieldbus connections. 2. Check that the master ensures a constant sequence of legal messages (FIELDBUS CONFIGURATION MENU) with max. time intervals lower than the preset watchdog time. 3. Set longer watchdog times (see R016). 4. To reset alarm A070, force communication between the Master and the Penta drive with bit 15 of the digital input word (bit 11 of the Control Word when using the PROFIdrive) as required by parameter R018b and reset the drive control board. If communication between the Master and the Slave (Penta) cannot be restored, alarm A070 is restored after setting parameter R016 to zero and after resetting the Penta drive. When the drive is next powered on, the alarm reset will affect the drive control board.

A072-3, A089-90 Parameter Upload/Download Error from Keypad to Drive

A072 A073 A089 A090	Description	Upload/download failed, one of the controls of the parameter consistency detected a fault.
	Event	A communication error occurred while uploading/downloading the programming parameters from the keypad to the drive.
	Possible cause	Temporary interruption to the serial link between keypad and control board.
	Solution	Check the connection between the keypad and the control board, reset the alarm and perform a new upload/download procedure.

A074 Overload

A074	Description	Drive thermal protection tripped.
	Event	The output current has been exceeding the drive rated current for long periods.
	Possible cause	<ul style="list-style-type: none"> Current equal to I_{peak} + 20% for 3 seconds, or Current equal to I_{max} for 120 seconds (S05÷S30 2T/4T), Current equal to I_{max} for 60 seconds (S41÷S90 2T/4T and all the 5T/6T models)
	Solution	Check the drive current output during ordinary operation (M026 in the Measure Menu); check the mechanical conditions of the connected load (load locked / overload).

A075 Motor Overheated

A075	Description	Motor thermal protection tripped.
	Event	The software motor thermal protection tripped. Output current has been exceeding the motor rated current for long periods.
	Possible cause	<ul style="list-style-type: none"> • Poor mechanical conditions of the connected load. • Wrong setting of parameters in the Thermal Protection Menu.
	Solution	<ol style="list-style-type: none"> 1. Check mechanical conditions of the connected load. 2. Check parameters C265, C266, C267 (and equivalent parameters for motors 2 and 3) in the MOTOR THERMAL PROTECTION MENU.

A076 Limit Speed

A076	Description	The motor speed is too high.
	Event	<p>The motor speed is higher than the current value set in parameter C031 (for motor 1, or equivalent parameters for motors 2 and 3).</p> <p>If C031 = 0, the limit speed protection is disabled.</p> <p>If the encoder is disabled, the variable used for this software protection is:</p> <ul style="list-style-type: none"> • The current speed setpoint for IFD. • The estimated motor speed for VTC control.
	Possible cause	<ul style="list-style-type: none"> • Value of parameter C031 too low. • Torque reference too high for SLAVE mode.
	Solution	<ol style="list-style-type: none"> 1. Check the compatibility of the parameter with respect to the maximum speed parameter. 2. In SLAVE mode, check the torque reference value.

A079 Encoder Not Configured

A079	Description	FOC control, but encoder not correctly configured.
	Event	<p>The FOC control is active, but no encoder has been enabled with parameter C012 (for motor 1, or equivalent parameters for motors 2 and 3). Otherwise, no incremental encoder enabled for speed measure with parameter C189 (see the ENCODER/FREQUENCY INPUTS MENU).</p> <p>Otherwise, no position sensor on the expansion board has been configured via parameters R023a, R023b, R092 to R097 (see EXPANSION BOARD CONFIGURATION MENU).</p>
	Possible cause	<ul style="list-style-type: none"> • C012 = 0 (for motor 1, or equivalent parameters for motors 2 and 3). See the MOTOR CONFIGURATION MENU. • The value set in C189 does not enable any encoder for speed measure. • The FOC control has been improperly enabled. • Parameters R023a, R023b, R092 to R097 are not correctly set.
	Solution	Set parameters correctly.

A080 Speed Tracking

A080	Description	Speed measurement error.
	Event	The system detected an error between the measured speed and the speed setpoint. Speed has been exceeding the value set in parameter C193 for a time longer than the value set in parameter C192 . In case of speed feedback from encoder (encoder properly configured, FOC active and C012 , C055 , C098 = Yes), speed is measured from the encoder. In case of VTC control, speed is estimated based on a model of the asynchronous motor. This protection is enabled only if parameter C194 is not set at zero.
	Possible cause	<ul style="list-style-type: none"> • Wrong setting in parameters C192, C193, C194 (see the ENCODER/FREQUENCY INPUTS MENU). • Torque limit too low. • Connected load too heavy. • Encoder failure, encoder mechanical joint broken down, disconnection of one of the signal cables of the encoder.
	Solution	<ol style="list-style-type: none"> 1. Set parameters C192, C193 correctly. 2. Check torque limit value (see the INPUTS FOR REFERENCES MENU and the CONTROL METHOD MENU). 3. Check the mechanical load. 4. Make sure that the encoder works properly, check its mechanical connection to the motor and check that the encoder signal cables are properly connected to the terminals.

A081 Keypad Watchdog

A081	Description	Watchdog for the communication to the keypad.
	Event	Communication failed when the keypad was enabled as a reference source or a command source or when it was in Local mode (Watchdog time is equal to approx. 1.6 seconds)
	Possible cause	<ul style="list-style-type: none"> • Keypad cable disconnected. • Failure of one of the two connectors of the keypad. • Strong electromagnetic disturbance or radiated interference. • Keypad failure. • Incorrect setting in parameters relating to serial link 1 (see the SERIAL LINKS MENU).
	Solution	<ol style="list-style-type: none"> 1. Check the connection of the keypad cable. 2. Make sure that the keypad cable connectors are intact (on both drive side and keypad side). 3. Check communication parameters of serial link 1.

A082 Encoder Configuration

A082	Description	Functions programmed for MDI6 and MDI7 , or Encoder B selected and encoder board not detected.
	Event	<ul style="list-style-type: none"> • Encoder A has been selected for speed measure or as a reference source, but different digital command functions are programmed for terminals MDI6 and MDI7. • Encoder B has been selected for the speed measure or as a reference source, but the control board did not detect any optional encoder board.
	Possible cause	<ul style="list-style-type: none"> • Incorrect setting of the use of the encoders in parameter C189. • Incorrect programming of digital input functions. • Optional board for Encoder B is not fitted, has been improperly mounted or is faulty. Possible connector failure.
	Solution	<ol style="list-style-type: none"> 1. Check and adjust the value set in C189 (see the ENCODER/FREQUENCY INPUTS MENU). 2. Check and adjust the control function programming for digital inputs MDI6 and MDI7 (see the DIGITAL INPUTS MENU). 3. Check if optional encoder board is fitted and properly mounted.

A083, A084, A085 External Alarm

A083 (EXT1) A084 (EXT2) A085 (EXT3)	Description	A083: External alarm 1 A084: External alarm 2 A085: External alarm 3
	Event	The External Alarm (1, 2, 3) function has been programmed, but the relevant digital input is disabled (see the DIGITAL INPUTS MENU). If multiple digital command sources are programmed, alarms A083-A085 trip if one of the terminals in the active sources is disabled (see the CONTROL METHOD MENU).
	Possible cause	The cause for the alarm trip does not depend on the drive; check for the reason why the contact connected to terminal MDIx where the External Alarm function is programmed opens.
	Solution	Check external signal.

A087 ±15V Loss

A087	Description	Loss of ±15V.
	Event	<ul style="list-style-type: none"> • The voltage level of ±15V is inadequate.
	Possible cause	<ul style="list-style-type: none"> • Possible failure of the control board or other circuits in the Penta Drive.
	Solution	<ol style="list-style-type: none"> 1. Reset the alarm: send a RESET command. 2. If the alarm persists, please contact BRAMMER's Customer Service.

A091 Braking Resistor Overload

A091	Description	Overvoltage due to the overload of the braking resistor that has been operating for a time equal to the maximum time due to settings in C211 and C212 .
	Event	The braking resistance command was inhibited because the maximum ON time was expired and the energy caused by regeneration (that can no longer be dissipated) has led to overvoltage.
	Possible cause	This application requires an intense use of the Braking Resistor, for example in hoisting applications, where a long downstroke is required when the load is connected to the motor.
	Solution	<ol style="list-style-type: none"> 1. Reset the alarm: send a RESET command. 2. If the power dissipated by the braking resistance allows for a heavier use, set C211 with a greater ON time.

A093 Precharge: Bypass open

A093	Description	Bypass relay open.
	Event	The control board requested the closure of the bypass relay (or contactor) for the short-circuit of the DC-link capacitor precharge resistors, but no closing signal is sent (auxiliary of the relay) during functioning (precharge already closed).
	Possible cause	Failure in the relay control circuit or in the auxiliary signal circuit detecting relay closing.
	Solution	<ol style="list-style-type: none"> 1. Reset the alarm: send a RESET command. 2. If the alarm persists, please contact BRAMMER's Customer Service.

A094 Heatsink Overheated

A094	Description	IGBT heatsink temperature too high.
	Event	IGBT power heatsink overheated even if the cooling fan is on (see also A096 and A099).
	Possible cause	<ul style="list-style-type: none"> • Ambient temperature exceeding 40 °C. • Too high motor current. • Excessive carrier frequency for the application required.
	Solution	<ol style="list-style-type: none"> 1. Check ambient temperature. 2. Check motor current. 3. Decrease IGBT carrier frequency (see the CARRIER FREQUENCY MENU).

A095 Illegal Drive Profile Board

A095	Description	An illegal Drive Profile board is implemented.
	Event	Incorrect configuration of the optional Drive Profile board.
	Possible cause	<ul style="list-style-type: none"> • The Drive Profile board is configured for a different drive. • The Drive Profile board is not configured. • Faulty Drive Profile board.
	Solution	<ol style="list-style-type: none"> 1. Make sure that the Drive Profile board is correctly configured for the Sinus Penta drive. 2. Replace the Drive Profile board.

A096 Fan Fault

A096	Description	Fan alarm.
	Event	Power heatsink overheated with fan locked or disconnected or faulty (see also A094 and A099).
	Possible cause	Fan locked or disconnected or faulty.
	Solution	Replace fan.

A097 Motor Cables KO

A097	Description	Motor not connected.
	Event	This protection trips during autotune or DC Brake if the motor is not connected to the drive or if its current value is not compatible with the drive model.
	Possible cause	<ul style="list-style-type: none"> • One cable of the motor is disconnected. • The motor size is too small if compared to the drive size.
	Solution	<ol style="list-style-type: none"> 1. Check that motor cables are properly connected to terminals U, V, W. 2. Check the motor parameters; perform autotune procedure again (VTC and FOC controls).

A098 Illegal Motor

A098	Description	A disabled motor has been selected.
	Event	<ul style="list-style-type: none"> • Motor 2 is enabled, but only one motor can be enabled: C009=1 (see the MOTOR CONFIGURATION MENU). • Motor 3 is enabled, but only 1 or 2 motors can be enabled: C009=1 or 2 (see the MOTOR CONFIGURATION MENU).
	Possible cause	<ul style="list-style-type: none"> • Incorrect setting in parameter C009. • Incorrect setting of the digital input parameters enabling the selection functions for motor 2 (C173) and/or motor 3 (C174).
	Solution	<ol style="list-style-type: none"> 1. Check and enter the correct value for C009. 2. Check and enter the correct value for C173, C174. 3. Check the status of the digital commands for terminals C173 and C174. If remote command sources are selected, check the status of the commands that have been sent.

A099 Sensor 2 Fault

A099	Description	Sensor 2 fault.
	Event	Power heatsink overheated with cooling fan off (see also A094 and A096).
	Possible cause	Failure in temperature control device and/or cooling system.
	Solution	Please contact BRAMMER's Customer Service.

A100 MDI6 Illegal Configuration

A100	Description	Function programmed to MDI6 and frequency input A as well.
	Event	MDI6 terminal is programmed with a digital function command and as frequency input A .

	Possible cause	Incorrect programming of a command function for MDI6 , because frequency input A is already set in parameter C189 (FinA) (see the DIGITAL INPUTS MENU and the ENCODER/FREQUENCY INPUTS MENU).
	Solution	Check and adjust programming of the digital input functions and of parameter C189 .

A101 MDI8 Illegal Configuration

A101	Description	Function programmed to MDI8 and frequency input B as well.
	Event	MDI8 terminal is programmed with a digital function command and as frequency input B .
	Possible cause	Incorrect programming of a command function for MDI8 , because frequency input B is already set in parameter C189 (FinB) (see the DIGITAL INPUTS MENU and the ENCODER/FREQUENCY INPUTS MENU).
	Solution	Check and adjust programming of the digital input functions and of parameter C189 .

A102, A103, A104, A086 Current input > 20 mA

A102 (REF) A103 (AIN1) A104 (AIN2) A086 (XAIN5)	Description	A102: REF Current input (4÷20mA or 0÷20mA) greater than 20mA A103: AIN1 Current input (4÷20mA or 0÷20mA) greater than 20mA A104: AIN2 Current input (4÷20mA or 0÷20mA) greater than 20mA A086: XAIN5 Current input (4÷20mA or 0÷20mA) greater than 20mA
	Event	A current value greater than 20mA has been detected over one input (REF, AIN1, AIN2, XAIN5) set with the following ranges: 4÷20mA or 0÷20mA.
	Possible cause	<ul style="list-style-type: none"> Wrong setting of SW1 on the control board (except for A086). Failure in the current signal source.
	Solution	<ol style="list-style-type: none"> Check setting of SW1(except for A086). Check the current signal source.

A105, A106, A107, A108 PT100 Channel 1,2,3,4 Fault

A105 (Channel 1) A106 (Channel 2) A107 (Channel 3) A108 (Channel 4)	Description	A105: PT100 Channel 1 fault A106: PT100 Channel 2 fault A107: PT100 Channel 3 fault A108: PT100 Channel 4 fault
	Event	Hardware input out of the measure range of the drive.
	Possible cause	<ul style="list-style-type: none"> Wrong setting of SW1 or SW2 on optional control board ES847 Failure in the current signal source.
	Solution	<ol style="list-style-type: none"> Check setting of SW1 and SW2. Check the current signal source.

A109 Ambient Overtemperature

A109	Description	The ambient temperature is too high.
	Event	The control board has detected a too high ambient temperature.
	Possible cause	Inverter or cabinet overheated; failure of control board NTC.
	Solution	<ol style="list-style-type: none"> Open the cabinet and check its conditions. Also check measure M062. Reset the alarm: send a RESET command. If the alarm persists, please contact BRAMMER's Customer Service.



A110 Fieldbus Board Fault

A110	Description	Fault occurring in the fieldbus
	Event	The fieldbus board has detected a severe network failure.
	Possible cause	Wrong configuration of the fieldbus network and/or Fieldbus Master.
	Solution	<ol style="list-style-type: none"> 1. Reset the Penta drive 2. Establish a connection to the fieldbus, making sure that the Fieldbus Master configuration is correct 3. If the alarm persists, please contact BRAMMER's Customer Service.

A129 No Output Phase

A129	Description	Output phase loss
	Event	<p>The output current from one of phases U, V, W is close to zero, while the other phases are properly operating. Output phase loss is detected only if:</p> <ul style="list-style-type: none"> • IFD control is selected (C010=0) • Output power exceeds 1Hz • Parameter C225 is set greater than 0.
	Possible cause	One or multiple links to the motor (phases U, V, W) disconnected.
	Solution	<ol style="list-style-type: none"> 1. Check continuity between the drive and the motor. 2. If the alarm persists, please contact BRAMMER's Customer Service.



NOTE This alarm may be enabled only by Brammer and is to be explicitly requested at the time when ordering the drive.

A140 Torque Off not Safe

A140	Description	Malfunctioning of ENABLE-A and ENABLE-B inputs for the STO function
	Event	<p>The redundant circuitry for the drive enable (simultaneous activation of the ENABLE-A and ENABLE-B inputs) is no longer active, so opening those inputs does not guarantee that the STO function is properly implemented. For more details, please consult the Safe Torque Off Function - Application Manual.</p>
	Possible cause	Fault in the circuitry dedicated to the Safe Torque Off function.
	Solution	<ol style="list-style-type: none"> 1. Reset the alarm: send a RESET command. 2. If the alarm persists, please contact BRAMMER's Customer Service.

A141 Illegal Hardware

A141	Description	Penta Drive hardware incompatible with Penta SW
	Event	The Penta SW downloaded to the control board is incompatible with the Penta drive hardware.
	Possible cause	Illegal software downloaded.
	Solution	Download the correct release of the PD software. Please contact BRAMMER's Customer Service.

58.4. List of the DRIVECOM Alarm Codes

If a PROFIdrive expansion board is used (see PROFIDRIVE BOARD CONFIGURATION MENU), the Sinus Penta fault codes are also coded according to the DRIVECOM communication profile. The specific code is readable @ address 947 of the specific PROFIDRIVE PARAMETERS (see PROFIdrive COMMUNICATIONS BOARD USER MANUAL).

The DRIVECOM User Group e.V. is an association of international [drive manufacturers, universities, and institutes](#). It has set itself a goal to develop a simple integration of drives in open automation systems. The DRIVECOM User Group therefore decided to standardise the communication interface for accessing drives.

Also visit www.drivecom.org.

Table 137: List of the DRIVECOM alarm codes

Code	Meaning	Sinus Penta Fault	#
0000	No malfunction	–	A000
1000	General malfunction	NoCurrent Fault	A060
		AutoTune Fault	A065
		No Output Phase	A129
2000	Current		
2300	Current on device output side		
2310	Continuous overcurrent		
2311	Continuous overcurrent No. 1	SW OverCurrent	A044
2312	Continuous overcurrent No. 2	PWMA1 Fault	A051
2320	Short circuit / earth leakage	PWMA Fault	A041
		PWMA0 Fault	A050
		PWMA Not ON	A053
3000	Voltage		
3100	Mains voltage		
3130	Phase failure	Mains Loss	A064
3200	Internal voltage		
3210	Internal overvoltage	OverVoltage	A048
3220	Internal undervoltage	UnderVoltage	A047
4000	Temperature	PT100 Channel 1 Fault	A105
		PT100 Channel 2 Fault	A106
		PT100 Channel 3 Fault	A107
		PT100 Channel 4 Fault	A108
4100	Ambient		
4110	Excess ambient temperature	Amb.Overtemp.	A109
4300	Drive temperature		
4310	Excess drive temperature	Drive OverHeated	A074
		HeatSink Overheated	A094
5000	Device hardware		
5111	U1 = supply +/- 15 V	±15V Loss	A087
5200	Control	Torque Off Not Safe	A140
5210	Measurement control	ADC Not Tuned	A088
5220	Computing circuit		
5300	Operating unit	Parm Lost Chk	A072
		Parm Lost COM1	A073
		MMI Trouble	A078
		KeyPad WatchDog	A081
		Parm Lost COM2	A089
		Parm Lost COM3	A090
5400	Power section	Fan Fault	A096
		2nd Sensor Fault	A099
5440	Contactors		
5441	Contactactor 1 = manufacturer specific	Bypass Circuit Fault	A045
5442	Contactactor 2 = manufacturer specific	Bypass Connector Fault	A046
5443	Contactactor 3 = manufacturer specific	Bypass Circuit Open	A093
5500	Data storage		
5510	RAM	RAM Fault	A049

Code	Meaning	Sinus Penta Fault	#
6000	Device software		
6010	Software reset (Watchdog)		
6100	Internal software	False Interrupt	A043
		Generic Motorola	A063
		1ms Interrupt OverTime	A071
		Illegal Hardware	A141
6200	User software	User Fault	A040
6300	Data record		
6301	Data record No. 1	SW Version KO	A092
6302	Data record No. 2	Optional Board not in	A054
6303	Data record No. 3	Illegal XMDI in DGI	A042
6304	Data record No. 4	Illegal XMDI in DGO	A052
6305	Data record No. 5	Illegal XMDI in MPL	A057
6306	Data record No. 6	FOC No Encoder	A079
6307	Data record No. 7	Illegal Encoder Cfg	A082
6308	Data record No. 8	Illegal Motor Selected	A098
6309	Data record No. 9	MDI6 Illegal Configuration	A100
630A	Data record No. 10	MDI8 Illegal Configuration	A101
7000	Supplementary modules		
7100	Power		
7110	Brake chopper	Braking Resistor Overload	A091
7120	Motor	Motor Not Connected	A097
7300	Sensor	PTC Alarm	A055
		PTC Short Circuit	A056
		REF < 4mA	A066
		AIN1 < 4mA	A067
		AIN2 < 4mA	A068
		XAIN5 < 4mA	A069
		REF > 20mA	A102
		AIN1 > 20mA	A103
		AIN2 > 20mA	A104
		XAIN5 > 20mA	A086
7301	Tacho fault		
		Tracking Error	A080
		Encoder Fault	A059
		ABS Encoder Fault	A131
7310	Speed	Speed Alarm	A076
7500	Communication	Ser WatchDog	A061
		SR1 WatchDog	A062
		Fbs WatchDog	A070
		Illegal Drive Profile Board	A095
		Fieldbus Board Fault	A110
8000	Monitoring		
8300	Torque control		
8311	Excess torque	Motor OverHeated	A075
9000	External malfunction	External Alarm 1	A083
		External Alarm 2	A084
		External Alarm 3	A085

58.5. Warnings

Warning messages are displayed on the display/keypad. They are flashing messages that usually appear in line 1 or 2 of the first three lines of the display.



NOTE Warnings are neither protections nor alarms and are not stored to the fault list.

Some warnings simply state what's happening or suggest what to do when using the keypad. However, most of the warning messages are **Coded warnings**: they are displayed with letter “**W**” followed by two **digits** stating which warning is active at that moment. Example:

W	3	2	O	P	E	N	E	N	A	B	L	E
---	---	---	---	---	---	---	---	---	---	---	---	---

Warning messages are detailed in the following section.

58.6. Warning List

Table 138: Warning list

Warning	Alarm Message	Description
W03	SEARCHING...	The user interface is searching the data of the next page to display.
W04	DATA READ KO	Software warnings concerning data reading.
W06	HOME SAVED	The page displayed has been saved as the home page displayed at power on.
W07	DOWNLOADING	The keypad is writing to the drive the WORK zone parameters saved on its own flash memory.
W08	UPLOADING	The keypad is reading from the drive the WORK zone parameters that will be saved on its own flash memory.
W09	DOWNLOAD OK	Parameters were successfully downloaded (written) from the keypad to the drive.
W11	UPLOAD OK	Parameters were successfully uploaded (read) from the drive to the keypad.
W12	UPLOAD KO	The keypad interrupted parameter upload to the drive. Parameter reading has failed.
W13	NO DOWNLOAD	A Download procedure was queried, but no parameter is saved to the flash memory.
W16	PLEASE WAIT...	Wait until the system completes the operation required.
W17	SAVE IMPOSSIBLE	Parameter save is not allowed.
W18	PARAMETERS LOST	The keypad interrupted parameter download to the drive. Parameter writing has failed. As a result, not all parameters have been updated (parameter inconsistency).
W19	NO PARAMETERS LOAD	UPLOAD impossible.
W20	NOT NOW	The required function is not available at the moment.
W21	CONTROL ON	The required function is inhibited because the drive is running: ENABLE-A and ENABLE-B are active.
W23	DOWNLOAD VER. KO	Download failed because parameters saved to keypad memory relate to a SW version or product ID incompatible with the drive SW version or product ID.
W24	VERIFY DATA	Download preliminary operation underway, the system is checking the integrity and compatibility of the parameters saved in the keypad memory.
W28	OPEN START	Open and close the START signal to start the drive.
W31	ENCODER OK	Encoder tuning procedure finished: the encoder is correctly connected.
W32	OPEN ENABLE	Open and close the ENABLE-A and ENABLE-B signals to enable the drive.
W33	WRITE IMPOSSIBLE	Writing procedure impossible.
W34	ILLEGAL DATA	Illegal value entered, operation failed.
W35	NO WRITE CONTROL	Writing procedure impossible because Control is active and the drive is running.
W36	ILLEGAL ADDRESS	Illegal address entered, operation failed.
W37	ENABLE LOCKED	The drive is disabled and does not acknowledge the ENABLE-A and ENABLE-B commands because it is writing a Cxxx parameter.  CAUTION: The drive will start up as soon as writing is over!!!
W38	LOCKED	Editing mode cannot be accessed because parameter modification is disabled: P000 is different from P002 .
W39	KEYPAD DISABLED	Editing mode cannot be accessed because the keypad is disabled.
W40	FAN FAULT	Fan locked or disconnected or faulty.
W41	SW VERSION KO	Download impossible because of different SW Versions.
W42	IDP KO	Download impossible because of different IDPs (Identification Products).
W43	PIN KO	Download impossible because of different PINs (Part Identification Numbers).
W44	CURRENT CLASS KO	Download impossible because of different current classes.
W45	VOLTAGE CLASS KO	Download impossible because of different voltage classes.
W46	DOWNLOAD KO	Download impossible (generic cause).
W48	OT Time over	The preset threshold for the drive Operation Time has been exceeded.
W49	ST Time over	The preset threshold for the drive Supply Time has been exceeded.
W50	NTC Fault	NTC sensor for heatsink temperature disconnected or faulty.

58.7. State List

Table 139: State list

Number	State	Description
0	ALARM!!!	Alarm tripped
1	STARTING UP	The drive is starting up
2	MAINS LOSS	Mains loss
3	TUNING	The drive is tuning
4	SPEED SEARCHING	Searching for motor speed
5	DCB at START	DC Braking at start
6	DCB at STOP	DC Braking at stop
7	DCB HOLD	DC current for Hold function
8	MANUAL DCB	Manual DC Braking
9	LIMIT WHILE ACCEL.	Current/torque limit while accelerating
10	LIMIT WHILE DECEL.	Current/torque limit while decelerating
11	LIMIT AT ST. SPD	Current/torque limit at constant rpm
12	BRAKING	Braking module startup or deceleration ramp extension
13	RUN AT ST. SPEED	Drive running at speed set point
14	ACCELERATING	Drive running with motor in acceleration stage
15	DECELERATING	Drive running with motor in deceleration stage
16	INVERTER OK	Drive on Stand-by with no alarms tripped
17	FLUXING	Motor fluxing stage
18	FLUXED MOTOR	Motor fluxed
19	FIRE MODE RUN	Constant rpm in Fire Mode
20	FIRE MODE ACC.	Acceleration in Fire Mode
21	FIRE MODE DEC.	Deceleration in Fire Mode
22	INVERTER OK*	Drive on Stand-by with no alarms tripped; void warranty due to alarm trip in Fire Mode
25	SPARE	Board in Spare mode
27	WAIT NO ENABLE	Waiting for opening ENABLE-A and ENABLE-B commands
28	WAIT NO START	Waiting for opening START command
29	PIDOUT min DISAB	Drive disabled due to PID output < Min.
30	REF min DISABLED	Drive disabled due to REF < Min.
31	IFD WAIT REF.	Drive enabled with IFD control waiting for reference in order to start
32	IFD WAIT START	Drive enabled with IFD control waiting for START in order to start
33	DISABLE NO START	When fluxing, the RUN command was not given within the max. time set in C183 . The drive is kept disabled until the RUN command is given.

59. CUSTOM PARAMETERS

In the table below, you can write down settings that are different from the default values.

PAR.-Meaning	Default values	Modified values	PAR.-Meaning	Default Values	Modified values
P00x Access Level					
P001-AcsLev	0: Basic		P003-ModCmode	1:[StandBy+Fluxing]	
Product					
P263-Lang	1: ENGLISH				
P26x Display					
P264-ModNav	0: Menu		P264a-ModNavMenu	1: Yes	
P264b-ModMenu	0: Standard		P265-FirstPage	3: [Start Up]	
P266-kpd_type	1: Active Ref.				
P267-umis1_PID	0: Disable		P267a- Custom PID unit of measures	[%]	
P267b-umis1_PID2	0: Disable		P267c- Custom PID2 unit of measures	[%]	
P268-Measure n.1 Status Page	M004		P268y-Scaling Measure n.1 Status Page	100.00%	
P268a-Measure n.2 Status Page	M000		P268z-Scaling Measure n.2 Status Page	100.00%	
P268b-Measure n.1 Keypad Page	M006		P268c-Measure n.2 Keypad Page	M026	
P268d-Measure n.3 Keypad Page	M004		P268e-Measure n.4 Keypad Page	M000	
P268s-umisSpeed	rpm		P268t-kmisSpeed	100.00%	
P268u-umisTorque	Nm		P268v-kmisTorque	100.00%	
P269-DisabLOC/REM	0: No		P269-DisabFWD/REV	0: No	
P269b-EscKeyFunc	0: No				
P00x-P03x Ramps					
P009-Tup1	[*]		P010-Tdn1	[*]	
P012-Tup2	[*]		P013-Tdn2	[*]	
P014-Un.Meas1-2	[*]		P015-Tup3	[*]	
P016-Tdn3	[*]		P018-Tup4	[*]	
P019-Tdn4	[*]		P020-Un.Meas3-4	[*]	
P021a-Rnd.Sel1	1: On		P021b-Rnd.Sel2	1: On	
P021c-Rnd.Sel3	1: On		P021d-Rnd.Sel4	1: On	
P022-RndStartAcc	[*]		P023-RndStopAcc.	[*]	
P024-RndStartDec	[*]		P025-RndStopDec	[*]	
P026-T Tup	5.00 s		P027-T Tdn	5.00 s	
P028-T Un.Meas	1: 0.1 s		P029-J Tup	1 s	
P030-J Tdn	1 s		P031-SpdAccReset	1: Yes	
P032-TupFireM	[*]		P033-TdnFireM	[*]	
P05x-P07x Reference					
P050-REF	3: 0-10V		P051-REFMIN	0.0 V	
P051a-REFMIN_%	100%		P052-REFMAX	10.0 V	
P052a-REFMAX_%	100%		P053-REFOFFS	0.000 V	
P054-TauFilt REF	5 ms		P055-AIN1	2: 4-20mA	
P056-AIN1MIN	4.0 mA		P056a-AIN1MIN_%	100%	
P057-AIN1MAX	20.0 mA		P057a-AIN1MAX_%	100%	
P058-AIN1OFFS	0.000 mA		P059-TauFilt AIN1	5 ms	
P060-AIN2	2: 4-20mA		P061-AIN2MIN	4.0 mA	
P061a-AIN2MIN_%	100%		P062-AIN2MAX	20.0 mA	
P062a-AIN2MAX_%	100%		P063-AIN2OFFS	0.000 mA	
P064-TauFilt AIN2	5 ms		P065-SpdDisab	0 rpm	
P066-SpdDisabTime	0 s		P067-U/D Ramp	Square	
P068-U/D Mem	1: Yes		P068a-U/D1-StopRes	0: No	
P068b-U/D2-StopRes	0: No		P068c-U/D1SwSRes	0: No	
P068d-U/D2SwSRes	0: No		P069-U/D Range	1: Unipolar	
P070-Jog Ref	0%		P071-PulseMin	10000 Hz	
P071a-PulseMin_%	100%		P072-PulseMax	100000 Hz	
P072a-PulseMax_%	100%		P073-EncMin	0 rpm	



P073a-EncMin %	100%		P074-EncMax	1500 rpm	
P074a-EncMax %	100%				

PAR.-Meaning	Default values	Modified values	PAR.-Meaning	Default values	Modified values
P08x-P10x Multispeeds					
P080-Mspd.use	0:Preset Speed		P081-Spd1	0.00 rpm	
P083-Spd2	0.00 rpm		P085-Spd3	0.00 rpm	
P087-Spd4	0.00 rpm		P088-Spd5	0.00 rpm	
P089-Spd6	0.00 rpm		P090-Spd7	0.00 rpm	
P091-Spd8	0.00 rpm		P092-Spd9	0.00 rpm	
P093-Spd10	0.00 rpm		P094-Spd11	0.00 rpm	
P095-Spd12	0.00 rpm		P096-Spd13	0.00 rpm	
P097-Spd14	0.00 rpm		P098-Spd15	0.00 rpm	
P099-FireM_Spd	750.00 rpm		P100-Un.Meas	0: 0.01 rpm	
P101-P103 PID Multitorque					
P101-Trq1	0.0 %		P102-Trq2	0.0 %	
P103-Trq3	0.0 %				
P08x-P09x PID Multireference					
P080a-Mref.use PID	0:Preset Ref		P081a-Ref 1 PID	0.00	
P082a-Ref 2 PID	0.00		P083a-Ref 3 PID	0.00	
P084a-Ref 4 PID	0.00		P085a-Ref 5 PID	0.00	
P086a-Ref 6 PID	0.00		P087a-Ref 7 PID	0.00	
P099a-FireM_Ref PID	0.00				
P10x Prohibit Speeds					
P105-Velbp1	0 rpm		P106-Velbp2	0 rpm	
P107-Velbp3	0 rpm		P108-Bwbps	0 rpm	
P11x-P12x % Var. Ref.					
P115-VarPerc1	0.0 %		P116-VarPerc2	0.0 %	
P117-VarPerc3	0.0 %		P118-VarPerc4	0.0 %	
P119-VarPerc5	0.0 %		P120-VarPerc6	0.0 %	
P121-VarPerc7	0.0 %				
P12x-P15x Speed Loop					
P125-Ti min M1	0.500 s		P126-Ti max M1	0.500 s	
P128-Kp min M1	10.00		P129-Kp max M1	10.00	
P130-Err.min M1	1.00 %		P131-Err.max M1	1.00 %	
P135-Ti min M2	0.500 s		P136-Ti max M2	0.500 s	
P138-Kp min M2	10.00		P139-Kp max M2	10.00	
P140-Err.min M2	1.00 %		P141-Err.max M2	1.00 %	
P145-Ti min M3	0.500 s		P146-Ti max M3	0.500 s	
P148-Kp min M3	10.00		P149-Kp max M3	10.00	
P150-Err.min M3	1.00 %		P151-Err.max M3	1.00 %	
P152-curr_symm.	0 %		P153-Tauw	10 ms	
P15x-P17x FOC Regulator					
P155-Curr_Kp M1	3.00		P156-Curr_Ti M1	20.0 ms	
P158-Flux_Kp M1	0.00		P159-Flux_Ti M1	33 ms	
P162-Curr_Kp M2	3.00		P163-Curr_Ti M2	20.0 ms	
P165-Flux_Kp M2	0.00		P166-Flux_Ti M2	33 ms	
P169-Curr_Kp M3	3.00		P170-Curr_Ti M3	20.0 ms	
P172-Flux_Kp M3	0.00		P173-Flux_Ti M3	33 ms	
P175xx VTC Regulator					
P175h1-FluxBoost_M1	0.0 %		P175i1-BoostThLow_M1	15.0 %	
P175j1-BoostThHigh_M1	30.0 %		P175t1-Kp_M1	500.0	
P175u1-Tau1_M1	50 ms				
P175h2-FluxBoost_M2	0.0 %		P175i2-BoostThLow_M2	15.0 %	
P175j2-BoostThHigh_M2	30.0 %		P175t2-Kp_M2	500.0	
P175u2-Tau1_M2	50 ms				
P175h3-FluxBoost_M3	0.0 %		P175i3-BoostThLow_M3	15.0 %	
P175j3-BoostThHigh_M3	30.0 %		P175t3-Kp_M3	500.0	

PAR.-Meaning	Default values	Modified values	PAR.-Meaning	Default values	Modified values
P175u3-TauI_M3	50 ms				
P175a-lthDTc	5.00 %		P175b-DTperc	80.0 %	
P175c-Dtsplit	50.0 %				
P175k-ExtraFlux	110.0 %		P175l-PsiMinPerc	10.0 %	
P175o-TauFluxR	300 ms		P175w-VtcCtrlAtStop	Speed	
P17x-P21x Analog Outputs					
P176-AO1 Mode	1: +/-10V		P177-AO1 Sel	1: Motor Speed	
P178-AO1 Min	-1500.000 rpm		P179-AO1 Max	1500.000 rpm	
P180-AO1 Offset	0.000 V		P181-AO1 Filt	0.000 s	
P182-AO1 Out_min	-10.0 V		P183-AO1 Out_max	10.0 V	
P184-AO2 Mode	1: +/-10V		P185-AO2 Sel	2: Speed Ref.	
P186-AO2 Min	-1500.000 rpm		P187-AO2 Max	1500.000 rpm	
P188-AO2 Offset	0.000 V		P189-AO2 Filt	0.000 s	
P190-AO2 Out_min	-10.0 V		P191-AO2 Out_max	10.0 V	
P192-AO3 Mode	1: +/-10V		P193-AO3 Sel	5: Motor Current	
P194-AO3 Min	0.000 A		P195-AO3 Max	36.000 A	
P196-AO3 Offset	0.000 V		P197-AO3 Filt	0.000 s	
P198-AO3 Out_min	-10.0 V		P199-AO3 Out_max	10.0 V	
P200-PulsOut Mode	0: Disabled		P201-PlsOut Sel	1: Motor Speed	
P202-Pls Out Min	0 rpm		P203-Pls Out Max	0 rpm	
P204-Pls Out Fmax	10.00 kHz		P205-Pls Out Fmin	100.00 kHz	
P206-Pls Out Filt	0.000 s		P207-AO1Gain		
P208-AO2Gain			P209-AO3Gain	RESERVED	
P210-AO1Address	RESERVED		P211-AO2Address		
P212-AO3Address			P213-Sin Amp	100.0 %	
P214-Sin Freq	1.00 Hz		P215-Saw Freq	1.000 Hz	

PAR.-Meaning	Default Values	Modified values	PAR.-Meaning	Default Values	Modified values
P21x-P22x Timers					
P216-T1 delay On	0.0 s		P217-T1 delay Off	0.0 s	
P218-T2 delay On	0.0 s		P219-T2 delay Off	0.0 s	
P220-T3 delay On	0.0 s		P221-T3 delay Off	0.0 s	
P222-T4 delay On	0.0 s		P223-T4 delay Off	0.0 s	
P224-T5 delay On	0.0 s		P225-T5 delay Off	0.0 s	
P226a-Timer MDI1	0		P226b-Timer MDI2	0	
P226c-Timer MDI3	0		P226d-Timer MDI4	0	
P227a-Timer MDI5	0		P227b-Timer MDI6	0	
P227c-Timer MDI7	0		P227d-Timer MDI8	0	
P228a-Timer MDO1	0		P228b-Timer MDO2	0	
P228c-Timer MDO3	0		P228d-Timer MDO4	0	
P229a-Timer MPL1	0		P229b-Timer MPL2	0	
P229c-Timer MPL3	0		P229d-Timer MPL4	0	
P23x-P26x PID Parameters					
P236-PID Out Max	100.00 %		P237-PID Out Min	100.00 %	
P237a-Wake Up Mode	0: Disabled		P237b-Wake Up Level	0.00 %	
P238-Integ Max	100.00 %		P239-Der Max	100.00 %	
P240-PID Kp	1.000		P241-PID KpMult	0: 1	
P242-PID Ti(Tc)	500 Tc		P243-PID Td(Tc)	0 mTc	
P244-PID Tc	5 ms		P245-PID Ref Min	0.00 %	
P246-PID Ref Max	100.00 %		P247-PID Fdbk Min	0.00 %	
P248-PID Fdbk Max	100.00 %		P249-PID Tup	0.00 s	
P250-PID Tdn	0.00 s		P251-PID U.Meas.	1: 0.1 s	
P252-Rnd start	50 %		P253-Rnd stop	50 %	
P254-Thresh Int	0.0 % Refmax		P255-Disab Time	Disabled	
P256-Trate Lim	1 ms		P257-GainScale	1.000	
P260-GainAWUP	1.00				
P27x-P30x Digital Outputs					
P270-Out1Mode	3: Analog		P271-Out1Sel1	A71: Speed	
P272-Out1Sel2	A71: Speed		P273-Out1 Test1	0: >	
P274-Out1 Test2	3: ≤		P275-D01 ValTst1	50.000 rpm	
P276-D01 ValTst2	10.000 rpm		P277-Out1Func	1: (A) Set (B) Reset	
P277a-Out1Sel1	D0: Disable		P277b-Out1Func	0: f(A,B) OR (C)	
P278-Out1Logic	1: True		P279-Out2Mode	6: Brake	
P280-Out2Sel1	A81: Torque output		P281-Out2Sel2	A71: Speed	
P282-Out2 Test1	0: >		P283-Out2 Test2	3: ≤	
P284-D02 ValTst1	20.000 %		P285-D02 ValTst2	50.000 rpm	
P286-Out2Func	1: (A) Set (B) Reset		P286a-Out2Sel1	D0: Disable	
P286b-Out2Func	0: f(A,B) OR (C)		P287-Out2Logic	1: True	
P288-Out3Mode	1: Digital		P289-Out3Sel1	D3: Inverter Alarm	
P290-Out3Sel2	D3: Inverter Alarm		P291-Out3 Test1	0: >	
P292-Out3 Test2	0: >		P293-D03 ValTst1	0.000	
P294-D03 ValTst2	0.000		P295-Out3Func	0: (A) OR (B)	
P295a-Out3Sel1	D0: Disable		P295b-Out3Func	0: f(A,B) OR (C)	
P296-Out3Logic	0: False		P297-Out4Mode	1: Digital	
P298-Out4Sel1	D1: Inverter Run Ok		P299-Out4Sel2	D1: Inverter Run Ok	
P300-Out4 Test1	0: >		P301-Out4 Test2	0: >	
P302-D04 ValTst1	0.000		P303-D04 ValTst2	0.000	
P304-Out4Func	0: (A) OR (B)		P304a-Out4Sel1	D0: Disable	
P304b-Out4Func	0: f(A,B) OR (C)		P305-Out4Logic	1: True	



PAR.-Meaning	Default Values	Modified values	PAR.-Meaning	Default Values	Modified values
P306-P317 Aux Digital Outputs					
P306-Out1Sel	D0: Disable		P307-Out1Logic	1: True	
P308-Out2Sel	D0: Disable		P309-Out2Logic	1: True	
P310-Out3Sel	D0: Disable		P311-Out3Logic	1: True	
P312-Out4Sel	D0: Disable		P313-Out4Logic	1: True	
P314-Out5Sel	D0: Disable		P315-Out5Logic	1: True	
P316-Out6Sel	D0: Disable		P317-Out6Logic	1: True	
P32x PT100 Settings					
P320-Mea1 Type	0:Disable		P321-Offset Mea1	0	
P322-Mea2 Type	0:Disable		P323-Offset Mea2	0	
P324-Mea3 Type	0:Disable		P325-Offset Mea3	0	
P326-Mea4 Type	0:Disable		P327-Offset Mea4	0	
P33x Fieldbus Parameters					
P330-fbs_meas3	M012 Torq.Out.%		P331-fbs_meas4	M022 PID Out%	
P35x-P38x MPL					
P350-Out1Mode	0: Disable		P351-Out1Sel1	D0: Disable	
P352-Out1Sel2	D0: Disable		P353-Out1 Test1	0: >	
P354-Out1 Test2	0: >		P355-D01 ValTst1	0	
P356-D01 ValTst2	0		P357-Out1Func	0: (A) OR (B)	
P357a-Out1Sel1	D0: Disable		P357b-Out1Func	0: f(A,B) OR (C)	
P358-Out1Logic	1: True		P359-Out2Mode	0: Disable	
P360-Out2Sel1	D0: Disable		P361-Out2Sel2	D0: Disable	
P362-Out2 Test1	0: >		P363-Out2 Test2	0: >	
P364-D02 ValTst1	0		P365-D02 ValTst2	0	
P366-Out2Func	0: (A) OR (B)		P366a-Out2Sel1	D0: Disable	
P366b-Out2Func	0: f(A,B) OR (C)		P367-Out2Logic	1: True	
P368-Out3Mode	0: Disable		P369-Out3Sel1	D0: Disable	
P370-Out3Sel2	D0: Disable		P371-Out3 Test1	0: >	
P372-Out3 Test2	0: >		P373-D03 ValTst1	0	
P374-D03 ValTst2	0		P375-Out3Func	0: (A) OR (B)	
P375a-Out3Sel1	D0: Disable		P375b-Out3Func	0: f(A,B) OR (C)	
P376-Out3Logic	1: True		P377-Out4Mode	0: Disable	
P378-Out4Sel1	D0: Disable		P379-Out4Sel2	D0: Disable	
P380-Out4 Test1	0: >		P381-Out4 Test2	0: >	
P382-D04 ValTst1	0		P383-D04 ValTst2	0	
P384-Out4Func	0: (A) OR (B)		P384a-Out4Sel1	D0: Disable	
P384b-Out4Func	0: f(A,B) OR (C)		P385-Out4Logic	1: True	
P39x Auxiliary Reference					
P390-XAIN4	3: 0-10V		P391-XAIN4MIN	0.0 V	
P391a-XAIN4MIN_%	100%		P392-XAIN4MAX	10.0 V	
P392a-XAIN4MAX_%	100%		P393-XAIN4OFFS	0.000 V	
P394-TauFilt XAIN4	100 ms		P395-XAIN5	2: 4-20mA	
P396-XAIN5MIN	4.0 mA		P396a-XAIN5MIN_%	100%	
P397-XAIN5MAX	20.0 mA		P397a-XAIN5MAX_%	100%	
P398-XAIN5OFFS	0.000 mA		P399-TauFilt XAIN5	100 ms	
P43x-P46x PID2 Parameters					
P436-PID2 Out Max	100.00 %		P437-PID2 Out Min	100.00 %	
P437a-Wake Up Mode	0: Disabled		P437b-Wake Up Level	0.00 %	
P438-Integ Max	100.00 %		P439-Der Max	100.00 %	
P440-PID2 Kp	1.000		P441-PID2 KpMult	0: 1	
P442-PID2 Ti(Tc)	500 Tc		P443-PID2 Td(Tc)	0 mTc	
P444-PID2 Tc	5 ms		P445-PID2 Ref Min	0.00 %	
P446-PID2 Ref Max	100.00 %		P447-PID2 Fdbk Min	0.00 %	
P448-PID2 Fdbk Max	100.00 %		P449-PID2 Tup	0.00 s	
P450-PID2 Tdn	0.00 s		P451-PID2 U.Meas	1: 0.1 s	
P452-Rnd start	50 %		P453-Rnd stop	50 %	
P454-Thresh Int	0.0 % Refmax		P455-Disab Time	Disabled	
P456-Trate Lim	1 ms		P457-GainScale	1.000	
P460-GainAWUP	1.00				

**SINUS PENTA
PENTA MARINE**



PROGRAMMING GUIDE



PAR.-Meaning	Default values	Modified values	PAR.-Meaning	Default values	Modified values
C00x-C00x Carrier Freq					
C001-Minimum Carrier	[*]		C002-Maximum Carrier	[*]	
C003- Pulse Number	1: 24		C004-Silent Modulation	[*]	
C00x-C04x Motor Control M1					
C008-VmainsNom	[**]		C009-Mot.Numb.	1	
C010-Ctrl.Type M1	0: IFD		C011-RefMode M1	0: Speed	
C011c-TrqFllwr M1	0: No		C012-EncEnab M1	0: No	
C013-v_f_mode1	[*]		C014-Phase Rot. Mot1	0: No	
C015-Fmot M1	50.0 Hz		C016-n mot M1	1420 rpm	
C017-Pmot M1	[*]		C018-Imot M1	[*]	
C019-Vmot M1	[**]		C020-P0 M1	0.0 %	
C021-i0 M1	0 %		C022-Rstat M1	[*]	
C023-Ld M1	[*]		C024-Lm M1	250.00 mH	
C025-TauRot M1	0 ms		C026-vdcFiltM1	0ms	
C028-nmin M1	0 rpm		C029-nmax M1	1500 rpm	
C030-spddeflux M1	Disabled		C030a- tau_i_defluxM1	500ms	
C031-nsa M1	Disabled		C032-red_Trq1	30.0 %	
C033-spd_redTrq1	20 %		C034-Preboost M1	[*]	
C035-Boost0 M1	[*]		C035a- FrqBst0 M1	5%	
C036-Boost M1	[*]		C037-FrqBst	[*]	
C038-AutoBst	[*]		C039-SlipComp. M1	Disabled	
C040-DV_M1	Disabled		C041-TFLM1	[*]	
C042-Vout Sat M1	100%				
	100%				
C04x-C05x Limits M1					
C043-lacclim M1					
C045-Ideclim M1	150%		C044-Irunlim M1	150%	
C047-Tmin M1	[*]		C046-defilimRed M1	0: Disabled	
	0.0 %		C048-Tmax M1	120%	
			C050-fRedLimAcc M1	0: Enabled	
C05x-C08x Motor Control M2					
C053-Ctrl.Type M2	0: IFD		C054-RefMode M2	0: Speed	
C054c-TrqFllwr M2	0: No		C055-EncEnab M2	0: No	
C056-v_f_mode2			C057-Phase Rot. Mot2	0: No	
C058-Fmot M2			C059-n mot M2	1420 rpm	
C060-Pmot M2			C061-Imot M2	[*]	
C062-Vmot M2			C063-P0 M2	0.0 %	
C064-i0 M2			C065-Rstat M2	[*]	
C066-Ld M2			C067-Lm M2	250.00 mH	
C068-TauRot M2			C069-vdcFiltM2	0ms	
C071-nmin M2			C072-nmax M2	1500 rpm	
C073-spddeflux M2			C073a- tau_i_defluxM2	500ms	
C074-nsa M2	Disabled		C075-red_Trq2		
C076-spd_redTrq2	20 %		C077-Preboost M2		
C078-Boost0 M2	[*]		C078a-FrqBst0 M2		
C079-Boost M2	[*]		C080-FrqBst M2		
C081-AutoBst	[*]		C082-SlipComp. M2		
C083-DV_M2	Disabled		C084-TFLM2		
C085-Vout Sat M2	100%				
C08x-C09x Limits M2					
C086-lacclim M2			C087-Irunlim M2	150%	
C088-Ideclim M2	150%		C089-defilimRed M2	0: Disabled	
C090-Tmin M2	[*]		C091-Tmax M2	120%	
	0.0 %		C093- fRedLimAcc M2	0: Enabled	

PAR.-Meaning	Default Values	Modified values	PAR.-Meaning	Default Values	Modified values
C09x-C12x Motor Control M3					
C096-Ctrl.Type M3	0: IFD		C097-RefMode M3	0: Speed	
C097c-TrqFillwr M3	0: No		C098-EncEnab M3	0: No	
C099-v_f_mode3	[*]		C100-Phase Rot. Mot3	0: No	
C101-Fmot M3	50.0 Hz		C102-n mot M3	1420 rpm	
C103-Pmot M3	[*]		C104-lmot M3	[*]	
C105-Vmot M3	[**]		C106-P0 M3	0.0 %	
C107-i0 M3	0 %		C108-Rstat M3	[*]	
C109-Ld M3	[*]		C110-Lm M3	250.00 mH	
C111-TauRot M3	0 ms		C112-vdcFiltM3	0ms	
C114-nmin M3	0 rpm		C115-nmax M3	1500 rpm	
C116-spddeflux M3	Disabled		C116a- tau_i_defluxM3	500ms	
C117-nsa M3	Disabled		C118-red_Trq3		
C119-spd_redTrq3	20 %		C120-Preboost M3		
C121-Boost0 M3	[*]		C121a- FrqBst0 M3		
C122-Boost M3	[*]		C123-FrqBst M3		
C124-AutoBst	[*]		C125-SlipComp. M3		
C126-DV_M3	Disabled		C127-TFLM3		
C128-Vout Sat M3	100%				
C12x-C13x Limits M3					
C129-lacclim M3	150%		C130-Irunlim M3	150%	
C131-Ideclim M3	[*]		C132-deflimRed M3	0: Disabled	
C133-Tmin M3	0.0 %		C134-Tmax M3	120%	
			C136- fRedLimAcc M3	0: Enabled	
C14x Control Method					
C140-Sel Comm 1	1: Terminals		C141-Sel Comm 2	1: Terminals	
C142-Sel Comm 3	0: Disabled		C143-Sel InRef 1	1: REF	
C144-Sel InRef 2	2: AIN1		C145-Sel InRef 3	0: Disabled	
C146-Sel InRef 4	0: Disabled		C147-Sel Lim	0: Disabled	
C148-RemLoc_mode	0: StandBy + Fluxing				
C15x-C18x Digital Inputs					
C149-Start	1: MDI1		C149a-StartB	0: None	
C150-Stop	0: None		C150a-StopB	0: None	
C151-Rev	0: None		C151a-RevB	0: None	
C152-Enable SW	0: None		C153-Disable	0: None	
C154-DisabReset	0: No		C154a-Ena Term	0: No	
C155-Mltsp 0	4: MDI4		C156-Mltsp 1	5: MDI5	
C157-Mltsp 2	0: None		C158-Mltsp 3	0: None	
C159-Cw-CCw	8: MDI8		C160-DCB	0: None	
C161-Up	0: None		C162-Down	0: None	
C163-U/D Reset	0: None		C164-ExtAlrm 1	0: None	
C164a-ExtAlr1Delay	0 ms		C165-ExtAlrm 2	0: None	
C165a-ExtAlr2Delay	0 ms		C166-ExtAlrm 3	0: None	
C166a-ExtAlr3Delay	0 ms		C167-MltRmp 0	0: None	
C168-MltRmp 1	0: None		C169-Jog	0: None	
C169a-reg_speed_switch	0: None				
C170-Master/Slave	0: None		C171-PID disab.	0: None	
C171a-PID sel. control	0: Disabled		C172-Keypad lock	0: None	
C173-2nd Mot.	0: None		C174-3rd Mot.	0: None	
C175-PercSpd 0	0: None		C176-PercSpd 1	0: None	
C177-PercSpd 2	0: None		C178-PIDud_res	0: None	
C179-SourceSel	0: MDI6		C179a-CmdSel	0:None	
C179b-RefSel	0: None		C180-Loc/Rem	0: MDI7	
C180a-Loc/RemType	2: Pushbutton+Storage		C181-Safe Start	0: Disabled	
C182-MultiProg	0: Disabled		C183-Tflux_dis	AlwaysON	
C184-StartFlux	0: No		C184a-TrqRedFluxing	0: No	
C185-StartFrWheel	0: Dec. Ramp		C186-FireMode	0: None	
C187-DisabExtTlim	0: None		C187a-Mtrq0	0: None	
C187b-Mtrq1	0: None		C188a-MrefPID 1	0: None	
C188b-MrefPID 2	0: None		C188c-MrefPID 3	0: None	



PAR.-Meaning	Default Values	Modified values	PAR.-Meaning	Default Values	Modified values
C18x-C19x Encoder/Frequency Input					
C189-UseEnc	0: A / B Unused		C190-pulsEncA	1024	
C191-pulsEncB	1024		C192-SpdAlrTime	5.00 s	
C193-SpdErr	300 rpm		C194-TrackAlrEn	1: Enable	
C195-tauFiltFdbk	5.0 ms		C196-tauFiltRef	5.0 ms	
C197-nCH ENCA	0: 2Ch. Quad		C198-nCH ENCB.	0: 2Ch. Quad	
C199-EncSign	0: Fdbk.NO Ref.NO				
C21x Braking Unit					
C210-Enab/Spd BrakeOn	[*]		C211-BrakeTon	2.00 s	
C212-BrkDutyCycle	10 %		C213-FreqBoost	0%	
C213a-KpVdcTrqRed	0.020		C213b-KiVdcTrqRed	0.010	
C213c-VdcTrqRedOvfxRef	100.0%		C213d-VdcTrqRedFluxRed	0.0%	
C21x-C22x DC Braking					
C215-Enab dcb stop	0: No		C216-Enab dcb start	0: No	
C217-Tdcb stop	0.5 s		C218-Tdcb start	0.5 s	
C219-dcb speed	50 rpm		C219a-TWRamp	500 ms	
C220-l dcb	100 %		C220a-TauIDCB	300 ms	
C220b-KplDCB	20		C220c-TauilDCB	100 ms	
C221-l dcb hold	0 %		C222-Tdefl M1	[*]	
C223-Tdefl M2	[*]		C224-Tdefl M3	[*]	
C22x-C23x Power Down					
C225-pwd type	3: Alarm		C226-Tpdd	10 ms	
C227-Tpdddec	20 s		C228-Pddecboost	0.10 %	
C229-Pddcder	1		C230-Vpddel	[**]	
C231-Kpvdclc	0.050		C232-Kivdclc	0.500s	
C234-stopmode	0: Stop		C235-stoplev	0 rpm	
C24x Speed Searching					
C245-Enab SpdSch	0: No		C246-tssd	1 s	
C247-SpsRate	10 %		C248-ls	75 %	
C249-SpsSpd	0: Last Speed		C250-SpdSch_En	0:Disable	
C25x AutoReset					
C255-nPulsRes	Disable		C256-T ResCyc	300 s	
C257-PowOnRes	0: No		C258-UvMISStore	0: No	
C26x-C27x Thermal Protection					
C264-FanTemp	50 °C		C265-ThermProt M1	3: Yes B	
C266-ThermCurr M1	105 %		C267-ThermConstM1	720s	
C268-ThermProt M2	3: Yes B		C269-ThermCurr M2	105 %	
C270-ThermConstM2	720s		C271-ThermProt M3	3: Yes B	
C272-ThermCurr M3	105 %		C273-ThermConstM3	720s	
C274-PTC ThermProt	0:Disable				
C27x Maintenance					
C276-Set OP Time	0h		C276-Set SP Time	0h	
C28x-C29x PID Configuration					
C285-Sel InPID 1	2: AIN1		C286-Sel InPID 2	0: Disabled	
C287-Sel InPID 3	0: Disabled		C288-Sel Fdbk 1 PID	3: AIN2/PTC	
C289-Sel Fdbk 2 PID	0: Disable		C290-Sel Fdbk 3 PID	0: Disable	
C291-PID Mode	0: Disable		C291a-PID Control mode	0: Standard SUM	
C291b-PID Mode	0: Disable		C292-Der Mode	0: Measure	
C293-PID Struct	0: No		C294-PID Act	1: Reference	
C30x Crane					
C300-StartTrq ref.pos.	0.0 %		C301-t_StartTrq ref.pos.	0 ms	
C300a-StartTrq ref.neg.	0.0 %		C301a-t_StartTrq ref.neg.	0 ms	
C302-Brk_On	0: None		C303-Brk_Off_on_track_err	1: Yes	



PAR.-Meaning	Default Values	Modified values	PAR.-Meaning	Default Values	Modified values
C31x Date and Time					
C310-ModWeekday	1: Monday		C311-ModDay	1	
C312-ModMonth	1: January		C313-ModYear	0	
C314-ModHour	0		C315-ModMin	0	
C316-Modify Date					
C33x-C35x Timed Flags					
C330-TFL1: T on h	0		C331-TFL1: T on m	0	
C332-TFL1: T on s	0		C333-TFL1: T off h	0	
C334-TFL1: T off m	0		C335-TFL1: T off s	0	
C336-TFL1: WeekDays	0		C337-TFL2: T on h	0	
C338-TFL2: T on m	0		C339-TFL2: T on s	0	
C340-TFL2: T off h	0		C341-TFL2: T off m	0	
C342-TFL2: T off s	0		C343-TFL2: WeekDays	0	
C344-TFL3: T on h	0		C345-TFL3: T on m	0	
C346-TFL3: T on s	0		C347-TFL3: T off h	0	
C348-TFL3: T off m	0		C349-TFL3: T off s	0	
C350-TFL3: WeekDays	0		C351-TFL4: T on h	0	
C352-TFL4: T on m	0		C353-TFL4: T on s	0	
C354-TFL4: T off h	0		C355-TFL4: T off m	0	
C356-TFL4: T off s	0		C357-TFL4: WeekDays	0	

PAR.-Meaning	Default Values	Modified values	PAR.-Meaning	Default Values	Modified values
R00x-R01x Serial Link					
R001-com_slaveaddr	1		R002-com_answdelay	5 ms	
R003-sc0_baudrate	38400 bps		R004-com_4time_delay	2 ms	
R005-ser_wdg_time	0.0 s		R006-parity_sc0	1: No, 2 Stop Bit	
R008-cm1_slaveaddr	1		R009-cm1_answdelay	5 ms	
R010-sc1_baudrate	38400 bps		R011-cm1_4time_delay	2 ms	
R012-sr1_wdg_time	0.0 s		R013-parity_sc1	1: No, 2 Stop Bit	
R01x Fieldbus Configuration					
R016-fbs_wdg_time	0 ms		R017a-AO1_fb_sel	0: No	
R017b-AO2_fb_sel	0: No		R017c-AO3_fb_sel	0: No	
R018-fb_Address	0		R018a-fb_BaudRate	125k	
R018b-fb_TypeWD	0 → bit 15 to 1				
R02x Expansion Board Settings					
R021-Data Logger Setting	1: NO		R023- I/O Board setting	0:None	
R02x-R04x PROFIdrive Settings					
R025-SlaveAddr	1		R026-PZD3 O Addr	1: Digital Inputs	
R027-PZD4 O Addr	0: not used		R028-PZD5 O Addr	0: not used	
R029-PZD6 O Addr	0: not used		R030-PZD7 O Addr	0: not used	
R031-PZD8 O Addr	0: not used		R032-PZD9 O Addr	0: not used	
R033-PZD10 O Addr	0: not used		R034-PZD3 I Addr	0: not used	
R035-PZD4 I Addr	0: not used		R036-PZD5 I Addr	0: not used	
R037-PZD6 I Addr	0: not used		R038-PZD7 I Addr	0: not used	
R039-PZD8 I Addr	0: not used		R040-PZD9 I Addr	0: not used	
R041-PZD3 I Addr	0: not used		R044-DP com.mode	0: DP V0	
R045-DP sel.	1: VENDOR SPECIFIC 1				
R05x Daylight Saving Time					
R050-DSTOn WDM	5703		R051-DSTOn HHMM	200	
R052-DSTOff WDM	5710		R053-DSTOff HHMM	200	
R11x Data Logger					
R115-PIN card SIM	"0000"		R116-Preset Connections	0: Disable	

Key:

[*] Parameter depending on the current size.

[**] Parameter depending on the voltage class.

60. INDEX

2	
2-ZONE	205
A	
Alarm Codes List.....	503; 523
ALARMS AND WARNINGS.....	501
Alternative Command and Reference Sources .31; 348	
Analog and Frequency Outputs	162
Anti-windup	196
Application.....	89
AUTORESET.....	429
Autotune	42; 45; 281
AUX REFERENCES.....	275
AUXILIARY DIGITAL OUTPUTS	242
B	
BRIDGE CRANE	456
C	
CARRIER FREQUENCY.....	286
<u>Changeover from Remote to Local command</u> ..	<u>355</u>
Command Sources	342
CONTROL METHOD.....	341
Controlled Stop in Case of Power Failure.....	30
CURRENT BALANCING.....	149
Current loop	52
<u>CW/CCW Input</u>	<u>374</u>
D	
Data Logger	79; 496
DAYLIGHT SAVING TIME	494
DC Braking.....	30; <u>404</u>
DC Braking at Start and Non-condensing Function .	404
DC Braking at Stop	406
DC Braking Command Sent from Digital Input.....	407
<u>DCB Input</u>	<u>374</u>
DIGITAL INPUTS	356
Digital Output Mode.....	208
DIGITAL OUTPUTS	207
Digital PID Regulator	31
<u>DISABLE Input</u>	<u>371</u>
<u>Disable Loc/Rem Fwd/Rev Keys</u>	<u>102</u>
<u>Disable RESET Alarms on MDI3</u>	<u>371</u>
DISPLAY/KEYPAD.....	16
Download/Upload from the Keypad.....	24
DRIVECOM.....	523
<u>Dry Run</u>	<u>258</u>
E	
EEPROM.....	498
Electrical Specifications of the Connected Motor	292
ENABLE.....	360
<u>ENABLE-SW Input</u>	<u>370</u>
Encoder test	49
Encoder tune.....	49
ENCODER/FREQUENCY INPUTS.....	390
Equivalent Circuit of the Asynchronous Machine	293
ES836.....	390
ES847.....	275; 348
ES851.....	79; 496
ES913.....	390
<u>External Alarm Inputs</u>	<u>376</u>
External Torque Limit.....	37
F	
Fault List	83
Feedback	
speed	49
Feedback from Encoder	38; 394
Field Weakening.....	299; 316
FIELDBUS.....	479
Fire Mode.....	32; 87
<u>Fire Mode Enable Input</u>	<u>387</u>
FIRST STARTUP	42
<u>Fluxing at Activation</u>	<u>386</u>
<u>Fluxing Max. Time</u>	<u>386</u>
FOC.....	49; 291
<u>FOC Current Regulator</u>	<u>156</u>
<u>FOC Flux Regulator</u>	<u>157</u>
Frequency Output	164
<u>Functioning Times</u>	<u>77</u>
I	
I/O OPTIONAL BOARD	275; 348
IFD	42; 291
<u>Input for Reference Selection</u>	<u>384</u>
<u>Input for Source Selection</u>	<u>384</u>
Input for torque limit disable.....	388
INPUTS FOR REFERENCES.....	116
J	
JOG	133
<u>JOG Input</u>	<u>378</u>
K	
KEYPAD.....	93
KEYPAD LOCK Input.....	381
L	
<u>Language</u>	<u>87</u>
LEDs.....	27
Limits.....	335
LOC/REM	26; 349

LOC/REM Input 385
 Local Mode..... 94

M

Main Speed/Torque Reference 29
 MAINTENANCE 440
 Maximum Output Frequency 89
 MDI Multiprogramming Enable..... 386
 Menu Tree..... 17
 Method of Ziegler and Nichols..... 190
 MOTOR CONTROL..... 291
MOTOR SEL Input..... 381
 Motor Thermal Protection 30; 431
 Motor tune 42; 45; 50
 MPL..... 251
 Multimotor..... 30
MULTIRAMP Inputs..... 377
 MULTISPEED 136
Multispeed Inputs 373; 389

N

Navigation 19

O

Operation Time Counter..... 78
 Output Frequency 288

P

Parameter Modification 21
 PASSWORD..... 14; 91
 PID CONFIGURATION 441
PID DISABLE Input..... 379
 PID Feedback Reference..... 29
 PID PARAMETERS..... 189
 PID Reference 29
PID Up/Down Reset Input..... 383
PID/PID2 Units of measure 97
 PID2 PARAMETERS..... 205
 Pipe Fill 260
 Power Down..... 30; 413
 Power Off List 85
 PROFIDRIVE..... 491
 Prohibit Speeds 31; 139; 144
 PT100 76; 246
 PTC 432

R

REAL TIME CLOCK (RTC)..... 459
 Reference from Encoder..... 39; 394
 REFERENCE VARIATION PERCENT 139; 146
 Remote/Local..... 349
 RESET 363
Reset Up/Down Input..... 376
 RESISTOR BRAKING..... 399
REVERSE B Input..... 369
REVERSE Input 368

Root Page..... 93
 Rounding off..... 105

S

S Ramps..... 104
 SERIAL LINKS..... 474
 Serial Number 90
SLAVE Input..... 379
 Slip Compensation 30
Smart Voltage Control..... 400; 402
Source Selection Input..... 383
 SPEED LOOP 149
 Speed Ramps..... 103
 Speed regulator 52
 Speed Searching 30; 420
SPEED VAR. Inputs..... 382
 Speed/Torque Limit Reference 29
 Speed/Torque REFERENCE Sources..... 345
 START 359
START B Input..... 366
START Input 366
 START-UP..... 40
 State List..... 527
STOP B Input..... 368
STOP Input..... 367
STOP Mode..... 387
 Supply Time Counter 78
SVC 400; 402
 SW Versions 89

T

TIMERS 183
 Torque Control 292; 297; 308
 Torque Limit source 349
Torque Limit Source Ref. Disable Input 387
 Torque Ramps 106
Type of LOC/REM contact 385

U

UP and DOWN Inputs..... 374
 Up/Down 133
 USER LEVEL..... 91

V

Virtual Digital Outputs 251
 Voltage/Frequency Pattern..... 30; 294
 VTC 45; 281; 289; 291
 VTC Current Regulator 159; 160

W

Warning List 526
 WATCHDOG..... 474

X

XAIN4 275



XAIN5.....275